



**Date:** February 13, 2009

**Contact:** Technical Services

**Subject:** NHTSA Recall #09V-033, 2008-2009 Scarabeo 100 – Drivability issues / Emission System Modification

**Service Communication:** 2009-001 USA  \***RECALL NOTICE**\*

**Models affected:** 2008-2009 Scarabeo 100

**Background:** The 2008-2009 Scarabeo 100 models are fitted with a California emission system to comply with U.S. homologation requirements. Although various states may not require specific California emission specifications, all U.S. bikes are configured to meet this standard, simplifying production and model homologation.

**Concern:** Based on dealer feedback and testing performed at Aprilia, the emission system fitted to the Scarabeo 100 has been found to cause drivability complaints. Symptoms may include difficult starting, random stalling, low power, reduced top speed, float bowl overflowing, fuel in air box and various other fuel system anomalies. Fuel leakage, in the presence of an ignition source, could result in a fire.

**Correction:** The emission system fitted to the Scarabeo 100 models will require the specific modifications noted in this bulletin. As these modifications affect the layout, hose routing and connections of the evaporative emission system, the original factory applied "Hose Routing Diagram" emission sticker must be removed and a new "Hose Routing Diagram" emission sticker be applied in its place.

**Owner Notification:** Each owner of an affected Scarabeo100 will be notified by first class mail. In this letter Aprilia USA will describe the details of the concern, the cause and the correction addressed by this recall. In addition, Aprilia USA asks that each owner contact an authorized Aprilia dealer to arrange an appointment to have the parts and labor required of this recall completed. Please make every effort to accommodate your recall customers within your existing service schedule. In addition, Aprilia USA has provided each recall customer with details of the TREAD Act Reimbursement program. In short, this program provides a plan to reimburse a customer who has already paid for the same repair or update as described in the recall documents. A copy of the Owner Notification and the TREAD Act Reimbursement letters are attached.

**Important Note:** Under the National Traffic and Safety Act of 1966 as amended, if there has been a recall campaign, dealers must assure that all new vehicles and new items of replacement equipment are free of safety defects and comply with all applicable Federal Motor Vehicle Safety Standards at the time of delivery to the customer. **This means that Aprilia dealers may not deliver new or used Scarabeo 100 models to consumers, unless the safety defect or noncompliance has been remedied before delivery.**



**VIN Identification:** Please poll the GGP warranty system on [www.serviceaprilia.com](http://www.serviceaprilia.com) to determine the Scarabeo 100 VINS subject to this recall.

On [www.serviceaprilia.com](http://www.serviceaprilia.com) select “GGP” on left side of home page.

- 1) Once the GGP portal opens, select “Tech. Update- Campaign”, then “Enter recall coupons menu”.
- 2) Enter the VIN number under “Frame” and tab down using the TAB key on your keyboard
- 3) Under “Element” - view any recalls that apply.
- 4) If you observe the heading, “**Scarabeo 100 MY 08- Evaporative Emissions**” or “**Scarabeo 100 MY 09- Evaporative Emissions**”, this particular VIN is subject to the recall.
- 5) Depress the back button  to back out of the claim. (Note: Recall identification and recall claim entry are performed under the same function, so unless you have completed the recall do not continue to fill in the blocks to submit the claim. Submit the claim only when the recall work has been completed)

**IMPORTANT NOTE:** If you observe a pop-up message stating, “Vehicle does not belong to Recall Campaign”, and you are sure the VIN applies, please contact your technical support representative. In addition, a message stating, “Vehicle is not blocked” means all applicable recalls have been performed and claimed. In addition, past recall claims on a vehicle can be viewed under “Warranty”, then “View Vehicle Data”, then “Maintenance Jobs” in the pop-up.

#### Parts to order:

#### **Scarabeo 100:**

- 856063 – Fuel hose (150 mm lengths) -Qty. 1
- AP8104251 - unidirectional valve- Qty. 1
- AP8102159 – metallic clip -Qty. 1
- AP8144303 – “T” union -Qty.1 (to be substituted only if broken during disassembly)
- CM223301- Air intake orifice- Qty. 1 (to be installed if missing on vehicle)
- 894024 - **2008 Model emission sticker** -Qty 1. (Must be substituted for legal approval)
- 894061 - **2009 Model emission sticker** -Qty 1. (Must be substituted for legal approval)



## **Warranty claiming:**

### Warranty claiming procedure (Scarabeo 100 emission system modification)

- 1) Log on to serviceaprilia.com using your user name and password. Select “GGP” on left side of home page.
- 2) Once the GGP portal opens, select “Tech. Update - Campaign” then “ Enter Recall Coupons menu”.
- 3) Enter the VIN number under “Frame” and tab down using the TAB key on your keyboard
- 4) Under “Element”- select “**Scarabeo 100 MY 08- Evaporative Emissions**” or “**Scarabeo 100 MY 09- Evaporative Emissions**”
- 5) Under “Coupon Type” select, “Extraordinary”.
- 6) Under “Coupon Number” click the Question mark and a pop-up box will appear. Click on the number of the coupon that applies to the procedure that was performed (1, 2, etc) in the coupon box.
- 7) In the “Km/mls” box, enter the mileage of the bike.
- 8) In “Document No.” enter your in-house repair order number.
- 9) In “Document type” select “invoice”.
- 10) Under the “Date Carried Out”, enter the date in European format (dd/mm/yyyy)

When you are finished, submit the claim by clicking on the “Diskette Icon”  in the upper left hand corner of the screen.

Reimbursement: **Scarabeo 100- (60 minutes plus parts)**

## **Repair Procedure:**

### **Scarabeo 100 Repair Procedure**

**Step 1:** Remove seat assembly and plastic bodywork to gain access to fuel tank. Make sure black/white valve at fuel tank is mounted so that white part faces away from tank/filler neck. This orientation allows fuel vapor to easily flow to canister (very little restriction in this direction).

- **White/black valve** to be assembled with black side towards the fuel tank
- **One way valve** to be assembled with the arrow towards the fuel tank

# aprilia



**Step 2:** Swap routing of the canister hoses. Canister is in front section behind glove box. Remove front bodywork panel to gain access. The hose attached to the big nipple of the canister should go to the fuel tank, not the air boot/air box. In addition, when looking at the top of the canister, make sure vent hose attached to this nipple is not kinked against horn bracket.

Swap hose connections at canister if connections are not as shown below:

- Nozzle “**Serb**” connected to fuel tank (shorter hose that goes to “T” and to fuel tank)
- Nozzle “**collett**” connected to the intake manifold (longer hose)

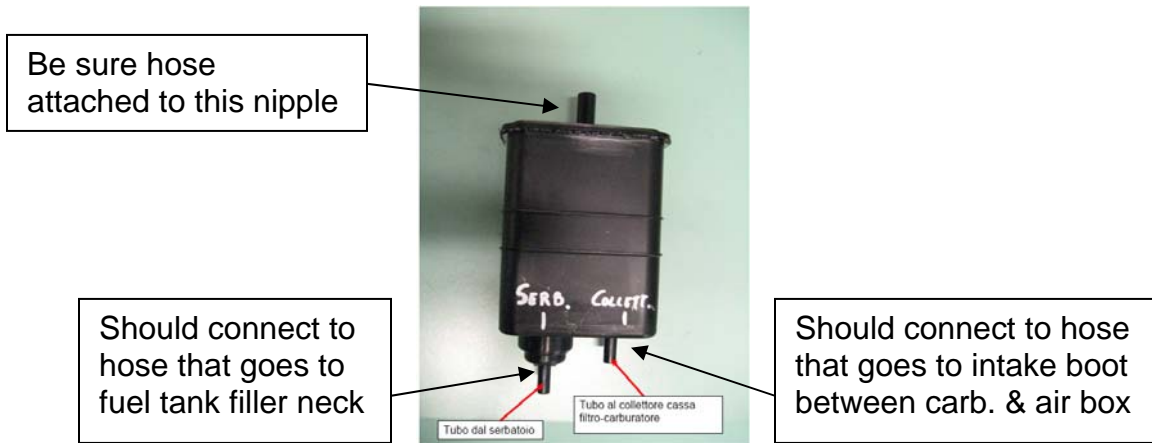



**Step 3:** Perform modification to carburetor float bowl vent hose

A) Unscrew the two screws of the inspection cover (fig. 1-2).



fig.1



fig.2

B) Open the clip and remove carburetor vent hose from “T” union. (fig.3-4).



fig.3



fig.4

Use caution: “T” union is fragile!

C) Attach the unsecured carburetor vent hose to hose bundle with a zip tie

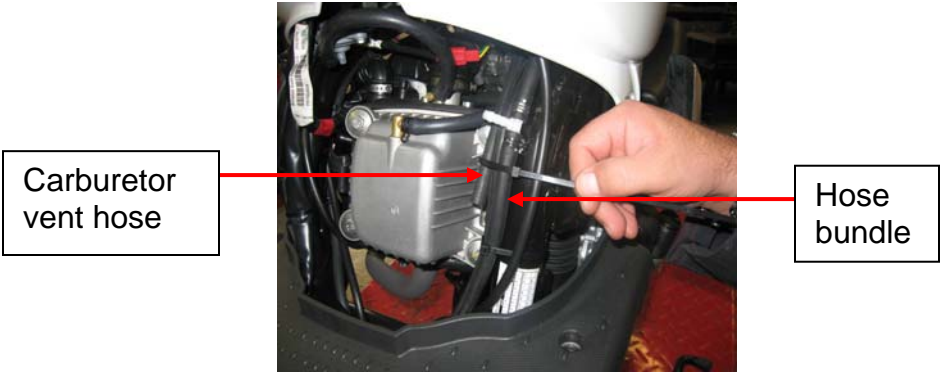



Take new hose code 856063 (length 150 mm) and attach one-way valve AP8104251 with new metallic clip AP8102159 (fig.6).

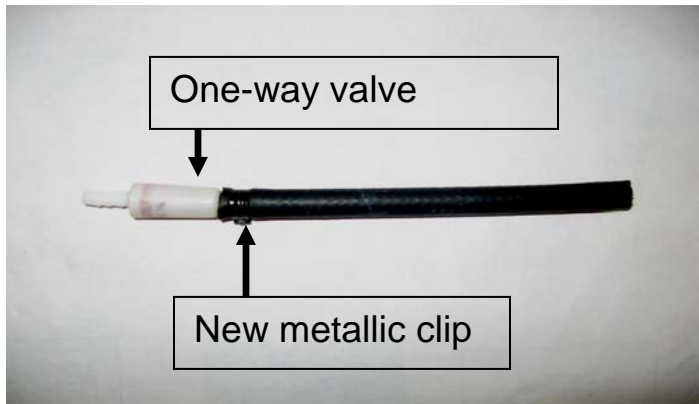

fig.6

CAUTION: The arrow on the valve must be positioned in hose direction. (fig.7).

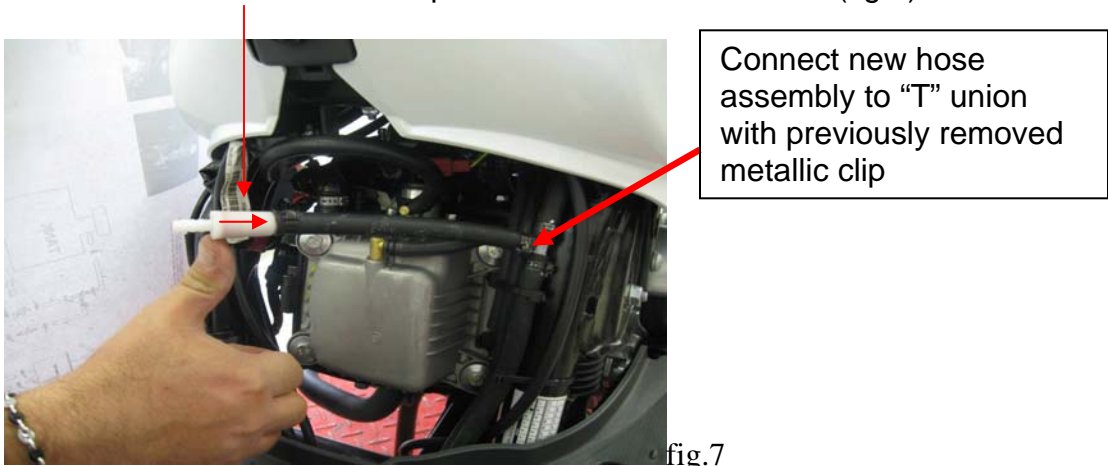

fig.7

E) Secure the new hose assembly to fuel hose with zip tie (fig.8)

# aprilia

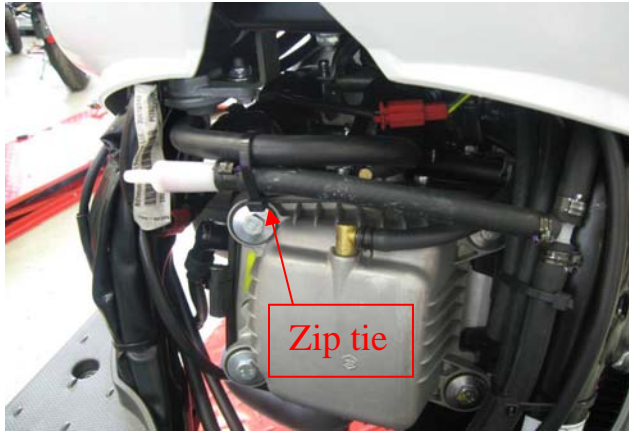
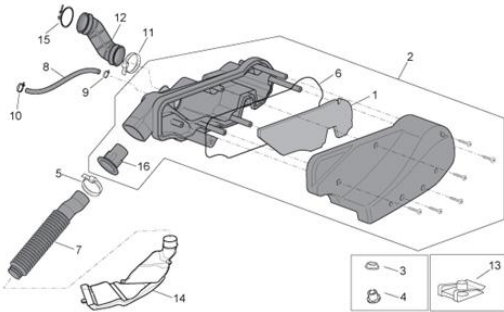

fig.8

**Step 4:** Be sure air box inlet has white plastic orifice #16 installed. (If not in place, scooter will be slow to accelerate to top speed when cold and can have poor performance when warm. This air orifice is meant for stock carburetor setup. If carburetor needle height or jets have been modified previously, the carburetor should be returned to the normal factory settings for correct idle speed and idle mixture)  
Part # CM223301





**Step 5:** Open glove box and remove emission system label from vehicle and install new emission system label in same location. Apply heat to remove label. Be sure surface is clean before installing new label.



**Step 6:** Re-install previously removed bodywork (rear seat & bodywork assembly, front body panel and engine inspection cover)



## **TREAD ACT CUSTOMER REIMBURSEMENT PLAN**

Customer Reimbursement for Safety Related Recall Repairs  
Effective with Safety related recalls initiated as of January 15, 2003

Aprilia USA is initiating a safety related recall for Scarabeo 100 models in a range of VINs that includes your vehicle. If you have previously paid to have the repair or update, as described in the recall documentation, completed you are entitled to be reimbursed for that expense.

You are encouraged to request reimbursement from your authorized Aprilia USA dealer. Alternatively, you may submit the request for reimbursement to the following address:

Aprilia Customer Care  
140, East 45<sup>th</sup> Street  
New York, NY 10017

In every case:

- Repair expenses pertaining to the subject of the safety recall are reimbursable, not consequential expenses such as towing, rental, accommodations, damage repairs, etc.
- Expenses from repair facilities outside of the Aprilia authorized dealer net work will be considered; however, the procedure must meet Aprilia standards and use Aprilia original equipment parts.
- When Aprilia original equipment parts are used, the Manufacturers Suggested Retail Price (MSRP) will be considered as the guideline for reasonable charges.
- Expenses for repairs performed more than 10 days after the date of the last customer notification letter sent by Aprilia are not eligible for reimbursement.
- Taxes and hazardous waste disposal, where previously paid, are eligible for reimbursement.
- Aprilia USA will not reimburse for prior repairs that did not use Aprilia original equipment parts.

The Aprilia authorized dealer will request a copy of the customer notification letter, as well as, a copy of the owner's previously paid invoice, and then inspect the vehicle (if still in the possession of the invoice holder) to determine the scope and quality of the previous repair. Claims will be processed within 60 days of receipt.



## **CUSTOMER NOTIFICATION LETTER**

February 16, 2009

Dear Aprilia Owner:

### **RE: IMPORTANT SAFETY RECALL INFORMATION REGARDING YOUR APRILIA SCARABEO 100 MOTOR SCOOTER**

This notice is sent to you in accordance with the requirements of the National Traffic and Motor Vehicle Safety Act. This notification is part of the NHTSA recall # 09V-033.

#### **REASON FOR THIS RECALL**

Aprilia USA has decided that a defect which relates to motor vehicle safety exists in the Aprilia motor scooter model and model years noted below:

- 2008 -2009 Scarabeo 100

The emission system on the above model within the noted model years may require modifications in order to ensure optimum engine performance. As an owner, you may experience some or all of the following symptoms: difficult starting, random stalling, low power and reduced top speed, float bowl overflowing, fuel in the air box and other fuel system anomalies. Fuel leakage, in the presence of an ignition source, could result in a fire.

Aprilia USA has identified the VIN range of the Scarabeo 100 model where checks and modifications need to be made. According to vehicle registration records, you are the owner of an Aprilia motor scooter that falls within this VIN range. Regardless of whether symptoms have manifested in your vehicle you will still need to contact your authorized dealer in order to have your vehicle checked.

#### **WHAT WE WILL DO**

To address this situation, Aprilia USA will conduct a voluntary recall of all 2008 - 2009 Aprilia Scarabeo 100 motor scooters within the defined VIN range. Aprilia USA, through the authorized Aprilia dealer network will make the necessary modifications to your vehicle to ensure optimum performance and EPA standardized emissions.

The work required of this recall may be completed by any authorized Aprilia dealer at no charge to you for the required parts or labor. The repair will take approximately 2.0 hours.

#### **WHAT YOU SHOULD DO**

With the receipt of this letter, please contact your authorized Aprilia dealer to arrange for an appointment to have the described vehicle updates completed. Instructions for the emissions system modifications have been sent to your dealer and the parts are available. Your dealer is best equipped to obtain parts and provide service to ensure that your vehicle is corrected as promptly as possible.

If, however, you take your vehicle to your dealer on the agreed service date, and they do not remedy this condition on that date or within three (3) days, we recommend you contact Aprilia Customer Care by calling (212) 380 4400, option #4.

After contacting your dealer and the above number, if you are still not able to have the safety defect remedied without charge and within a reasonable time, you may wish to write the Administrator, National Highway Traffic



Safety Administration, 1200 New Jersey Ave, SE, Washington, DC 20590 or call the toll-free Vehicle Safety Hotline at 1-888-327-4236 (TTY: 1-800-424-9153); or go to <http://www.safecar.gov>.

In the event that you have sold this vehicle or the vehicle is no longer in your possession, please complete and return the enclosed postage prepaid reply card to notify us of any change of ownership card.

If you previously had the work required of this recall completed at your own expense, please refer to the attached letter describing the criteria and procedure to request reimbursement.

We are sorry to cause this inconvenience; however, we have taken this action in the interest of your safety and continued satisfaction with our products. Thank you for your prompt attention to this important matter.

Very truly yours,

Aprilia USA.