

# DAIMLER

Daimler Trucks North America  
Nasser Zamani  
Senior Manager  
Compliance and Regulatory Affairs

December 15, 2009

Dan Smith  
Associate Administrator for Vehicle Safety  
National Highway Traffic Safety Administration  
1200 New Jersey Avenue S.E.  
Washington D.C. 20590

**Re: Defect Information Report – Supplemental Report No. 1  
09V-461, FL-569, KPPS Adjustable Brake Pedals**

Mr. Smith,

In accordance with Part 573 of Title 49 of the Code of Federal Regulations, Daimler Trucks North America LLC herewith submits supplemental defect information and copies of documents distributed to dealers and purchasers.

- (c)(3) Total number of vehicles potentially affected: 6052
- (c) (8)(ii) Communications sent to dealers: posted December 11, 2009  
Communications sent to owners: will be mailed by December 22, 2009
- (c) (10) Copies of Communications sent to owners and dealers are attached.

Please contact me if you have any questions.

Sincerely yours,



Nasser Zamani

Cc: Michael Mason, CAL-OSHA  
Enclosure  
Certified Mail#70032260000134203865

A Daimler Company

Daimler Trucks North America LLC  
4747 N. Channel Avenue  
Portland OR 97217-7699  
503-745-6910 Phone  
503-745-5544 Fax  
Nasser.Zamani@Daimler.com

## Subject: KPPS Adjustable Brake Pedals

Models Affected: Specific Freightliner Custom Chassis B2 school bus chassis (Thomas Built Buses Saf-T-Liner C2 school buses) manufactured October 6, 2004, through November 12, 2009, with certain Kongsberg Power Products Systems (KPPS) adjustable brake pedals.

### General Information

Daimler Trucks North America LLC, on behalf of its wholly owned subsidiary, Freightliner Custom Chassis Corporation, has decided that a defect that relates to motor vehicle safety exists on the vehicles mentioned above.

There are approximately 6,300 vehicles involved in this campaign.

The adjustable brake pedal may loosen. The drive pin which secures the brake pedal arm to the balance of the assembly may become disengaged, this may cause a reduction in vehicle braking and/or cause the brake pedal to move out of position and interfere with throttle pedal function. A reduction in braking or interference with the throttle pedal could result in a vehicle crash.

A clamp assembly will be installed on the adjustable brake pedal arm, preventing it from loosening. It is expected that all vehicles need the clamp assembly installed. An inspection is included to catch any vehicles that were repaired at the factory before delivery.

### Additional Repairs

Dealers must complete all outstanding recall and field service campaigns prior to the sale or delivery of a vehicle. A Dealer will be liable for any progressive damage that results from its failure to complete campaigns before sale or delivery of a vehicle.

Owners may be liable for any progressive damage that results from its failure to complete campaigns within a reasonable time after receiving notification.

### Work Instructions

Please refer to the attached work instructions. Prior to performing the campaign, check the vehicle for a completion sticker (Form WAR260).

### Replacement Parts

Replacement kits are now available and can be obtained by ordering the kit number(s) listed below from your facing Parts Distribution Center.

If our records show your dealership has ordered any vehicles involved in campaign number FL569A, a list of the customers and vehicle identification numbers will be available on AccessFreightliner.com. Please refer to this list when ordering parts for this recall.

# Recall Campaign

Daimler Trucks  
North America LLC

December 2009  
FL569A  
NHTSA #09V-461

**NOTE:** Completion stickers are not included in the kits. Please use blank completion stickers and write in the recall number, FL569.

**Table 1 - Replacement Parts for FL569A**

Campaign Number	Kit Number	Part Description	Part Number	Qty.	Suggested Wholesale*
FL569A	25-FL569-000	C-Clamp Assembly Kit	KPPS Kit #318282	1 kit	\$.70 U.S. \$1.01 CAN

\* Please charge all Direct Warranty Customers the above-listed price for the kit, as they are authorized to perform their own Recalls.

**Table 1**

## Removed Parts

Please follow Warranty Failed Parts Tracking shipping instructions for the disposition of all removed parts.

## Labor Allowance

**NOTE:** It is expected that all vehicles need the clamp assembly installed. An inspection is included to catch any vehicles that were repaired at the factory before delivery.

**Table 2 - Labor Allowance**

Campaign Number	Procedure	Time Allowed (hours)	SRT Code	Damage Code
FL569A	Inspect and install a C-clamp on the adjustable brake pedal	0.2	996-0798A	000-Modifiedx
	Inspect for C-clamp or roll pin on the adjustable brake pedal	0.2	996-0798B	000-Inspected

**Table 2**

**IMPORTANT:** When the recall has been completed, locate the base completion label in the appropriate location on the vehicle, and attach the red completion sticker provided in the recall kit (Form WAR260). If the vehicle does not have a base completion label, clean a spot on the appropriate location of the vehicle and first attach the base completion label (Form WAR259). If a recall kit is not required or there is no completion sticker in the kit, write the recall number on a blank sticker and attach it to the base completion label.

## Claims for Credit

You will be reimbursed for your parts, labor, and handling by submitting your claim through the Warranty system within 30 days of completing this campaign. Please reference the following information in QuickClaim®:

- Claim type is **Recall**.
- In the FTL Authorization field, enter the campaign number and appropriate condition code (**FL569A**).
- In the Primary Failed Part Number field, enter **25-FL569-000**.
- In the Parts field, enter the appropriate kit number(s) as shown in the Replacement Parts Table.
- In the Labor field, first enter the appropriate SRT from the Labor Allowance Table. For administrative time, enter SRT 939-0010A for 0.3 hours.

- **Reimbursement for Prior Repairs.** When a customer asks about reimbursement, please do the following.
  - Accept the documentation of the previous repair.
  - Make a brief check of the customer's paperwork to see if the repair may be eligible for reimbursement. (See the "Copy of Owner Letter" section of this bulletin for reimbursement guidelines for this recall.)
  - Contact the Warranty Campaigns Department for a decision and authorization number.
  - Include the approved amount on your claim in sublet/outside purchases.
  - In the claim story, first note the authorization number and that the claim includes a reimbursement request.
  - Retain the documentation and provide it to Warranty Campaigns or Claims Processing if requested.
  - When your claim is paid, reimburse the customer the appropriate amount.

**IMPORTANT:** ServicePro® must be viewed prior to performing the recall to ensure the vehicle is involved and the campaign has not been previously completed. Also, check for a completion sticker prior to beginning work.

Contact the Warranty Campaigns Department at (800) 547-0712, from 7:00 a.m. to 4:00 p.m. Pacific Time, Monday through Friday, Web inquiry at [AccessFreightliner.com / Support / Submit an Inquiry](http://AccessFreightliner.com/Support/SubmitanInquiry), or the Customer Assistance Center at (800) 385-4357, after normal business hours, if you have any questions or need additional information.

To return excess kit inventory related to this campaign, U.S. dealers must submit a Parts Authorization Return (PAR) to the Memphis PDC. Canadian dealers must submit a PAR to their facing PDC. All kits must be in resalable condition. PAR requests must include the original purchase invoice number.

The letter notifying vehicle owners is included for your reference.

Please note that the National Traffic and Motor Vehicle Safety Act, as amended (Title 49, United States Code, Chapter 301), requires the owner's vehicle(s) be corrected within a reasonable time after parts are available to you. The Act states that failure to repair a vehicle within 60 days after tender for repair shall be prima facie evidence of an unreasonable time. However, circumstances of a particular situation may reduce the 60 day period. Failure to repair a vehicle within a reasonable time can result in either the obligation to (a) replace the vehicle with an identical or reasonably equivalent vehicle, without charge, or (b) refund the purchase price in full, less a reasonable allowance for depreciation. The Act further prohibits dealers from selling a vehicle unless all outstanding recalls are performed. Any lessor is required to send a copy of the recall notification to the lessee within 10 days. Any subsequent stage manufacturer is required to forward this notice to its distributors and retail outlets within five working days.

# Recall Campaign

Daimler Trucks  
North America LLC

December 2009  
FL569A  
NHTSA #09V-461

## Copy of Letter to Owner Subject: KPPS Adjustable Brake Pedals

This notice is sent to you in accordance with the requirements of the National Traffic and Motor Vehicle Safety Act. This notice is also sent in accordance with the Canadian Motor Vehicles Safety Act.

Daimler Trucks North America LLC, on behalf of its wholly owned subsidiary, Freightliner Custom Chassis Corporation, has decided that a defect which relates to motor vehicle safety exists on specific Freightliner Custom Chassis B2 school bus chassis (Thomas Built Buses Saf-T-Liner C2 school buses) manufactured October 6, 2004, through November 12, 2009, with certain Kongsberg Power Products Systems (KPPS) adjustable brake pedals.

The adjustable brake pedal may loosen. The drive pin which secures the brake pedal arm to the balance of the assembly may become disengaged, this may cause a reduction in vehicle braking and/or cause the brake pedal to move out of position and interfere with throttle pedal function. A reduction in braking or interference with the throttle pedal could result in a vehicle crash.

A clamp assembly will be installed on the adjustable brake pedal arm, preventing it from loosening.

Parts are now available for authorized dealers to order. Contact your authorized dealer to arrange to have the recall performed and to ensure that parts are available at the dealership. To locate a dealer, search online at [www.FreightlinerTrucks.com](http://www.FreightlinerTrucks.com) or contact the Warranty Campaigns Department for assistance.

When you contact your dealer, refer to campaign number **FL569A**. Once kit(s) are received at the dealership, the Recall will take approximately half an hour and will be performed at no charge to you.

**IMPORTANT:** When the Recall has been completed, please ensure that a label has been affixed to your vehicle referencing **FL569A**.

If you do not own the vehicle that corresponds to the identification number(s) which appears on the Recall Notification, please return the notification to the Warranty Campaigns Department with any information you can furnish that will assist us in locating the present owner. If you have leased this vehicle, Federal law requires that you forward this notice to the lessee within 10 days. If you are a subsequent stage manufacturer, Federal law requires that you forward this notice to your distributors and retail outlets within five working days. If you have paid to have this recall condition corrected prior to this notice, you may be eligible to receive reimbursement. Please see the reverse side of this notice for details.

If you are not able to have the defect remedied without charge and within a reasonable time, which is not longer than 60 days after you tender the vehicle for repair, please contact the Warranty Campaigns Department at (800) 547-0712, 7:00 a.m. to 4:00 p.m. Pacific Time, Monday through Friday, e-mail address [DTNA.Warranty.Campaigns@Daimler.com](mailto:DTNA.Warranty.Campaigns@Daimler.com), or the Customer Assistance Center at (800) FTL-HELP or (800) STL-HELP, after normal business hours. You may also wish to submit a complaint to the Administrator, National Highway Traffic Safety Administration, 1200 New Jersey Avenue, SE., Washington, DC 20590; or call the Vehicle Safety Hotline at (888) 327-4236 (TTY: 800-424-9153); or to <http://www.safercar.gov>. If your vehicle is involved in the Canadian portion, you may wish to notify Transport Canada, ASFAD, Place de Ville Tower C, 330 Sparks Street, Ottawa, ON K1A 0N5, or phone (800) 333-0510.

We regret any inconvenience this action may cause but feel certain you understand our interest in motor vehicle safety.

WARRANTY CAMPAIGNS DEPARTMENT

Enclosure

December 2009  
FL569A  
NHTSA #09V-461

## Work Instructions

### Subject: KPPS Adjustable Brake Pedals

**Models Affected:** Specific Freightliner Custom Chassis B2 school bus chassis (Thomas Built Buses Saf-T-Liner C2 school buses) manufactured October 6, 2004, through November 12, 2009, with certain Kongsberg Power Products Systems (KPPS) adjustable brake pedals.

NOTE: It is expected that all vehicles need the clamp assembly installed. An inspection is included to catch any vehicles that were repaired at the factory before delivery.

#### Inspection

1. Check the base label (Form WAR259) for a completion sticker for campaign FL569 (Form WAR260) indicating this work has been done. The base label is usually located above the driver's window on school buses. If a completion sticker for this campaign is present, no further work is needed. If a completion sticker is not present, proceed with the next step.
2. Park the vehicle on a level surface, shut down the engine, apply the parking brake, and chock the tires.
3. Check to see if a C-clamp or roll pin is installed on the adjustable brake pedal. See **Fig. 1**.
4. If either a C-clamp or a roll pin is found, no further work is needed. Clean a spot on the base label (Form WAR259), write the recall number, FL569, on a blank completion sticker (Form WAR260), and attach it to the base label. Remove the chocks from the tires.

If a C-clamp or a roll pin is not found, go to "C-clamp Installation" below.

#### C-clamp Installation

NOTE: The bolt threads come equipped with an application of Loctite®.

1. With the C-clamp in your hand, install the C-clamp assembly in the guide hole at the top of the brake arm casting. Make certain the C-clamp is against the casting and tighten the top bolt  $40\pm 5$  lbf-in ( $452\pm 5$  N·cm). The bolt with the lockwasher should be installed at the top, as shown in **Fig. 1**, Items 4 and 5. Then tighten the bottom bolt  $40\pm 5$  lbf-in ( $452\pm 5$  N·cm).
2. Remove the chocks from the tires.
3. Clean a spot on the base label (Form WAR259), write the recall number, FL569, on a blank completion sticker (Form WAR260), and attach it to the base label.

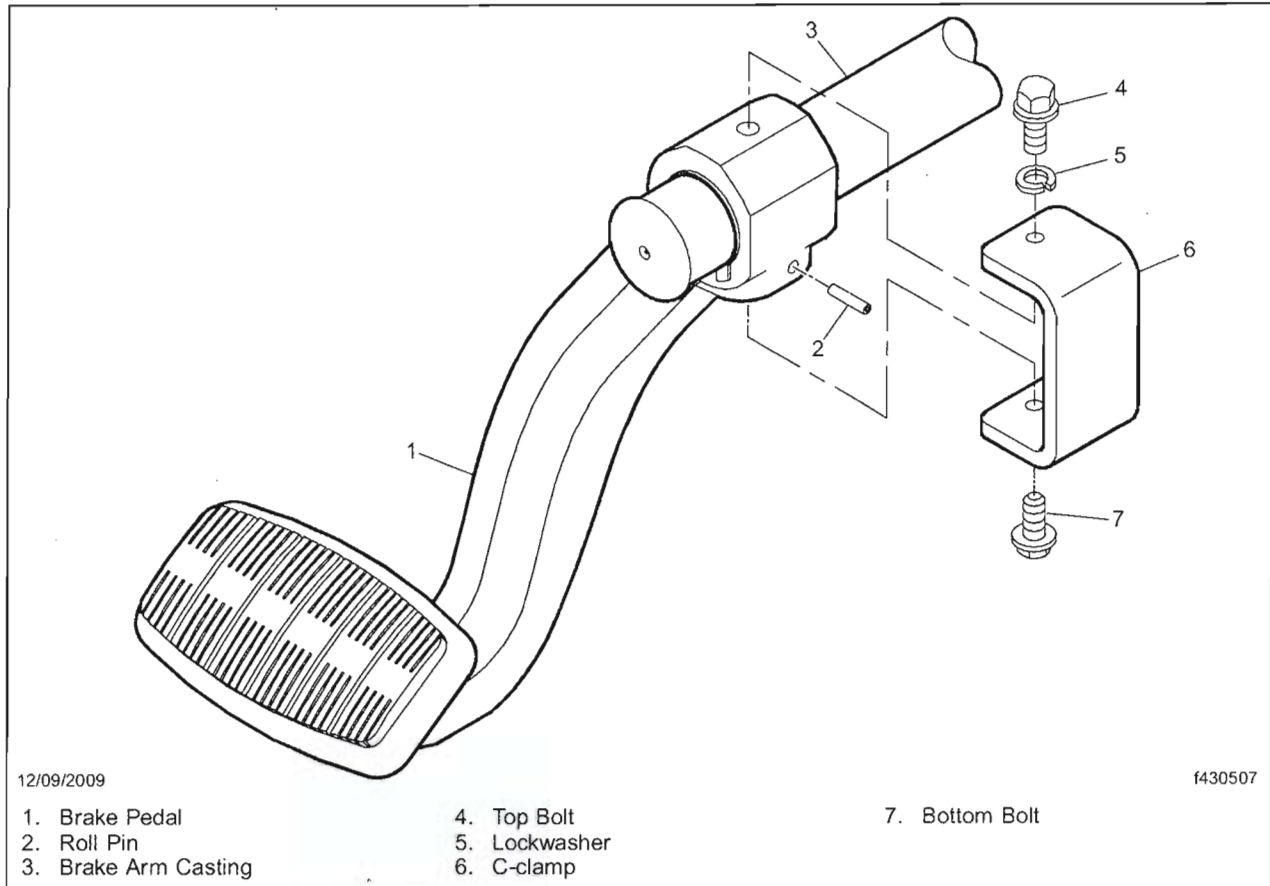

Fig. 1, Adjustable Brake Pedal Assembly