

Safety Defect and Noncompliance Report Guide for Vehicles  
**PART 573 Defect and Noncompliance Report**<sup>1</sup>

On March 4, 2009, Long Chih [MFR] decided that (a defect which relates to motor vehicle safety)(a noncompliance with Federal Motor Vehicle Safety Standard No. 110 ) exists in the motor vehicles listed below, and is furnishing notification to the National Highway Traffic Safety Administration in accordance with 49 CFR Part 573 Defect and Noncompliance Reports.

Date this report was prepared: March 4, 2009

Furnish the manufacturer's identification code for this recall (if applicable): \_\_\_\_\_

1. Identify the full corporate name of the fabricating manufacturer of the vehicle being recalled. If the recalled vehicle is imported, provide the name and mailing address of the designated agent as prescribed by 49 U.S.C. §30164.

Armor Rex Inc  
1361 Mountain View Circle  
Azusa, CA 91702

Identify the corporate official, by name and title, whom the agency should contact with respect to this recall.

Mr. Daniel Huang Telephone \_\_\_\_\_  
Number: (626) 969-0889 Ext. 215 Fax No.: (626) 969-0810 E-mail: Daniel@armorrex.com

Name and Title of Person who prepared this report.

David Wei  
Sales Manager

Signed:

2009 MAR 11 A 9:36  
RECEIVED  
NHTSA

<sup>1</sup>Each manufacturer must furnish a report, to the Associate Administrator for Safety Assurance, for each defect or noncompliance condition which relates to motor vehicle safety.

This guide was developed from 49 CFR Part 573, "Defect and Noncompliance Reports" and also outlines information currently requested. Any questions, please consult the complete Part 573 or contact Mr. Jon White at (202) 366-5227 or by FAX at (202) 366-7882.

**I. Identify the Vehicle Models Involved in the Recall**

**2. Identify the Vehicles Involved in the Recall, for each make and model or applicable vehicle line (provide illustrations or photographs as necessary to describe the vehicle), provide:**

**Make(s):** Long Chih **Model Years Involved:** 2005 to 2008 **Model(s):** LCI-240TA5, LCI-882G

**Production Dates: Beginning:** September 1, 2005 **Ending:** December 31, 2008

**VIN Range: Beginning:** 002811 **Ending:** 002981

**Vehicle Type:** Trailer **Bodystyle:** \_\_\_\_\_

**Descriptive information which characterizes/distinguishes the recalled vehicles from those model vehicles not included in the recall:**

**Make(s):** Long Chih **Model Years Involved:** 2005 to 2008 **Model(s):** LCI-248TE

**Production Dates: Beginning:** September 1, 2005 **Ending:** December 31, 2008

**VIN Range: Beginning:** 000001 **Ending:** 000150

**Vehicle Type:** Trailer **Bodystyle:** \_\_\_\_\_

Descriptive information which characterizes/distinguishes the recalled vehicles from those model vehicles not included in the recall:

**Make(s):** Long Chih **Model Years Involved:** 2005 to 2008 **Model(s):** LCI-745TC

**Production Dates: Beginning:** September 1, 2005 **Ending:** December 31, 2008

**VIN Range: Beginning:** 002973 **Ending:** 004057

**Vehicle Type:** Trailer **Bodystyle:** \_\_\_\_\_

Descriptive information which characterizes/distinguishes the recalled vehicles from those model vehicles not included in the recall:

**Make(s):** Long Chih **Model Years Involved:** 2005 to 2008 **Model(s):** LCI-746TE

**Production Dates: Beginning:** September 1, 2005 **Ending:** December 31, 2008

**VIN Range: Beginning:** 000801 **Ending:** 002321

**Vehicle Type:** Trailer **Bodystyle:** \_\_\_\_\_

Descriptive information which characterizes/distinguishes the recalled vehicles from those model vehicles not included in the recall:

**Make(s):** Long Chih **Model Years Involved:** 2005 to 2008 **Model(s):** LCI-748TC

**Production Dates: Beginning:** September 1, 2005 **Ending:** December 31, 2008

**VIN Range: Beginning:** 000431 **Ending:** 000480

Vehicle Type: Trailer Bodystyle: \_\_\_\_\_

Descriptive information which characterizes/distinguishes the recalled vehicles from those model vehicles not included in the recall:

Make(s): Long Chih Model Years Involved: 2005 to 2008 Model(s): LCI-749TC, LCI-749TE, LCI-850T, LCI-850TA, LCI-851T, LCI-851TA, LCI-851TAX, LCI-852T, LCI-958TC, LCI-958TR

Production Dates: Beginning: September 1, 2005 Ending: December 31, 2008

VIN Range: Beginning: 319555 Ending: 355688

Vehicle Type: Trailer Bodystyle: \_\_\_\_\_

Descriptive information which characterizes/distinguishes the recalled vehicles from those model vehicles not included in the recall:

Make(s): Long Chih Model Years Involved: 2005 to 2008 Model(s): LCI-830T, LCI-830TA, LCI-832T, LCI-832TA

Production Dates: Beginning: September 1, 2005 Ending: December 31, 2008

VIN Range: Beginning: 355556 Ending: 370270

Vehicle Type: Trailer Bodystyle: \_\_\_\_\_

Descriptive information which characterizes/distinguishes the recalled vehicles from those model vehicles not included in the recall:

Make(s): Long Chih Model Years Involved: 2005 to 2008 Model(s): LCI-880P

Production Dates: Beginning: September 1, 2005 Ending: December 31, 2008

VIN Range: Beginning: 036078 Ending: 044585

Vehicle Type: Trailer Bodystyle: \_\_\_\_\_

Descriptive information which characterizes/distinguishes the recalled vehicles from those model vehicles not included in the recall:

Make(s): Long Chih Model Years Involved: 2005 to 2008 Model(s): LCI-881G, LCI-881PA

Production Dates: Beginning: September 1, 2005 Ending: December 31, 2008

VIN Range: Beginning: 021740 Ending: 024121

Vehicle Type: Trailer Bodystyle: \_\_\_\_\_

Descriptive information which characterizes/distinguishes the recalled vehicles from those model vehicles not included in the recall:

Make(s): Long Chih Model Years Involved: 2005 to 2008 Model(s): LCI-890T

---

Production Dates: Beginning: September 1, 2005 Ending: December 31, 2008

VIN Range: Beginning: 0002165 Ending: 000456

Vehicle Type: Trailer Bodystyle: \_\_\_\_\_

Descriptive information which characterizes/distinguishes the recalled vehicles from those model vehicles not included in the recall:

**Identify the approximate percentage of the production of all the recalled models manufactured by your company between the inclusive dates of manufacture provided above, that the recalled model population represents. For example, if the recall involved Widgets equipped with certain items of equipment from January 1, 1996 through April 1, 1997, then what was the percentage of the recalled Widgets of all Widgets manufactured during that time period.**

80% of total production of trailer between the inclusive date of manufacture provide above was missed the tire placard label for USA market, the balance 20% trailer was shipped to another country market

## **II. Identify the Recall Population**

**3. Furnish the total number of vehicles recalled potentially containing the defect or noncompliance.**

<b>Model</b>	<b>Year</b>	<b>Number of Vehicles Potentially Involved</b>
<u>LCI-240TA5</u>	<u>2008</u>	<u>50</u>
<u>LCI-248TE</u>	<u>2008</u>	<u>150</u>
<u>LCI-745TC</u>	<u>05-08</u>	<u>655</u>
<u>LCI-746TE</u>	<u>06-08</u>	<u>755</u>
<u>LCI-748TC</u>	<u>2008</u>	<u>50</u>
<u>LCI-749TC</u>	<u>05-08</u>	<u>497</u>
<u>LCI-749TE</u>	<u>05-06</u>	<u>55</u>
<u>LCI-830T</u>	<u>05-08</u>	<u>9089</u>
<u>LCI-830TA</u>	<u>05-08</u>	<u>2991</u>
<u>LCI-832T</u>	<u>05-06</u>	<u>528</u>
<u>LCI-832TA</u>	<u>05-08</u>	<u>852</u>
<u>LCI-850T</u>	<u>05-08</u>	<u>5677</u>
<u>LCI-850TA</u>	<u>05-06</u>	<u>135</u>
<u>LCI-851T</u>	<u>05-08</u>	<u>8330</u>
<u>LCI-851TA</u>	<u>2008</u>	<u>836</u>
<u>LCI-851TAX</u>	<u>05-08</u>	<u>5268</u>
<u>LCI-852T</u>	<u>05-06</u>	<u>8160</u>
<u>LCI-880P</u>	<u>05-08</u>	<u>7401</u>
<u>LCI-881G</u>	<u>05-07</u>	<u>66</u>
<u>LCI-881PA</u>	<u>2008</u>	<u>120</u>
<u>LCI-882G</u>	<u>05-06</u>	<u>121</u>

LCI-890T	06-08	241
LCI-958TC	2008	656
LCI-958TR	05-08	1105
<b>Total Number Potentially Affected by the Recall:</b>		<b>53788</b>

4. Furnish the approximate percentage of the total number of vehicles estimated to actually contain the defect or noncompliance: 80%

Identify and describe how the recall population was determined--in particular how the recalled models were selected and the basis for the beginning and final dates of manufacture of the recalled vehicles:

1. All our trailers must have a tire placard label to permanently affix on the driver's side of tow bar near VIN plate.
2. Every trailer has a VIN in our file when the trailer was manufactured.
3. Manufacture of trailer between the included date is from September 1, 2005 to December 31, 2008.

### **III. Describe the Defect or Noncompliance**

**5. Describe the defect or noncompliance. The description should address the nature and physical location of the defect or noncompliance. Illustrations should be provided as appropriate.**

1. Our trailer was missing a tire placard label (tire loading information)
2. This tire placard should be permanently affixed to the driver's side of trailer tow bar near the VIN plate.
3. Attached please see the location of the tire placard label as illustration.

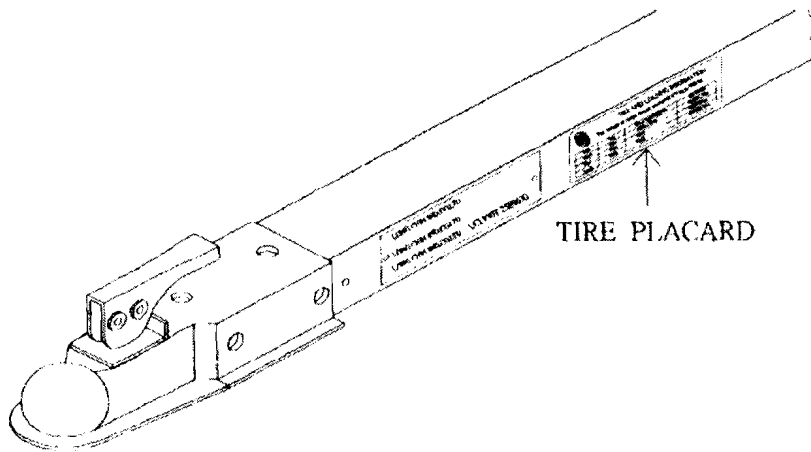

---

**Describe the cause(s) of the defect or noncompliance condition.**

Miss a tire placard label.

**Describe the consequence(s) of the defect or noncompliance condition.**

It will make confusion for the cargo maximum capacity although there is an actual statement in the owner's manual.

**Identify any warning which can (a) precede or (b) occur.**

It may make a over loading.

---

**If the defect or noncompliance is in a component or assembly purchased from a supplier, identify the supplier by corporate name and address.**

None

**Identify the name and title of the chief executive officer or knowledgeable representative of the supplier:**

None

#### **IV. Provide the Chronology in Determining the Defect/Noncompliance**

*If the recall is for a defect, complete item 6, otherwise item 7.*

**6. With respect to a defect, furnish a chronological summary (including dates) of all the principle events that were the basis for the determination of the defect. The summary should include, but not be limited to, the number of reports, accidents, injuries, fatalities, and warranty claims.**

**7. With respect to a noncompliance, identify and provide the test results or other data (in chronological order and including dates) on which the noncompliance was determined.**

On 11/25, 2008 the OVSC has information indicating that the trailer identified, which was purchased by a consumer from Northern Tools and Equipment, does not comply with requirement of FMVSS No. 110, Tire selection and rims for motor vehicle with a GVWR of 4,536 kilogram (10,000 pounds) or less and Regulation Parts 575 consumer information regulation.

#### **V. Identify the Remedy**

**8. Furnish a description of the manufacturer's remedy for the defect or noncompliance. Clearly describe the differences between the recall condition and the remedy.**

1. Long Chih trailer does not comply with requirement of FMVSS No. 110 between the included manufactured date was from September 1, 2005 to December 31, 2008

2. Send a tire placard label to the trailer owner who indicated name, address on the returning warranty registration card to our designated agency and ask owner to permanently affix this label to the driver side of trailer tow bar near VIN plate.

3. Inform owner that the GVWR and GAWR in VIN plate unit is pounds.

4. Inform owner that trailer model LCI-830T, LCI-832T, LCI-850T, LCI-851T trailer's GVWR is 1,170 pounds.

5. Provide "Reporting Safety Defects" statement as a part of owner's manual.

6. We will keep some inventory of "tire placard label" and statement sheet at importer for trailer owner once request.

7. Long Chih Company will remedy that noncompliance without charge.

**Clearly describe the distinguishing characteristics of the remedy component/assembly versus the recalled component/assembly.**

1. Tire placard is a label with viscose shown the tire size, tire pressure and cargo loading weight limited.

2. "Reporting Safety Defects" is a statement if trailer owner believe that vehicle has a defect which could cause a crash or could cause injury or death, owner should immediately inform the NHTSA.

**Identify and describe how and when the recall condition was corrected in production. If the production remedy was identical to the recall remedy in the field, so state. If the product was discontinued, so state.**  
1. From January 1, 2009, all Long Chih trailer was corrected in production for requirement of FMVSS standard.

### **VI. Identify the Recall Schedule**

Furnish a schedule or agenda (with specific dates) for notification to other manufacturers, dealers/retailers, and purchasers. Please, identify any foreseeable problems with implementing the recall.

1. After final confirmation from our importer, we will provide the tire placard label and statement sheet to our designated agency in one month.

2. We will accord returning warranty registration card showing owner's name, address information which was sent to our designated agency then send the tire placard label and statement to owner.

2. First month can be finished about 30%.

2. Second month can be finished about 30%

3. The Third month can be finished 40%.

### **VII. Furnish Recall Communications**

**9. Furnish a final copy of all notices, bulletins, and other communications that relate directly to the defect or noncompliance and which are sent to more than one manufacturer, distributor, or purchaser. This includes all communications (including both original and follow-up) concerning this recall from the time your**

**company determines the defect or noncompliance condition on, not just the initial notification. A *DRAFT* copy of the notification documents should be submitted to this office by Fax (202-366-7882) for review prior to mailing.**

**Note that these documents are to be submitted separately from those provided in accordance with Part 573.8 requirements.**

*The Privacy Act of 1974 - Public Law 93-579, As Amended: This information is requested pursuant to the authority vested in the National Highway Traffic Safety Act and subsequent amendments. You are under no obligation to respond to this questionnaire. Your response maybe used to assist the NHTSA in determining whether a manufacturer should take appropriate action to correct a safety defect. If the NHTSA proceeds with administration enforcement or litigation against a manufacturer, your response, or statistical summary thereof, may be used in support of the agency's action.*

---

**LONG CHIH INDUSTRIAL COMPANY LIMITED**

101, Show Shan Road, Shinchuang City, Taipei Hsien, Taiwan, ROC  
Tel: 886-2-29068666 Fax: 886-2-2906-8669 E-mail: longchih@ms31.hinet.net

Dear Customer:

This notice is sent to you in accordance with the requirements of the National Traffic and Motor Vehicle Safety Act.

Long Chih – trailer manufacturer has decided that all our trailers from 9/1, 2005 to 12/31, 2008 fail to conform to Federal Motor Vehicle Safety Standard No. 110. Tire selection and rims for motor vehicle with a GVWR of 4.536 kilogram (10,000 pounds) or less - doesn't comply with requirement as follow:

1. Missing a tire placard label, which stated the tire size, tire pressure and cargo should not exceed the load carrying weight. And it must be permanently affixed to the driver's side of trailer's tow bar. It will make confusion and emphasize that cargo maximum capacity, although it was stated on owner manual.
2. GVWR of LCI-830T, LCI-832T, LCI-850T, LCI-851T should be 1,170 pounds less instead of 1,180 pound. Because 4.80-8 tire/wheel 4-PR capacity was changed from 590 pound to 585 pound already.
3. The GVWR and GAWR unit should be pounds in VIN plate.
4. Regulation Title 49 Part 575 Consumer information – Should be added a consumer information as "Reporting Safety Defects" as a part of owner's manual. This statement show that if owner believe that your trailer has a defect which could cause a crash or could cause injury or death, you should immediately inform the National Highway Traffic Safety Administration (NHTSA) in addition to notifying Long Chih company.

What are we doing about the problem?

1. Send a tire placard label to trailer owner who indicated name, address on the returning warranty registration card to our designed agent and ask owner to affix this tire placard to the driver's side of trailer tow bar and near VIN plate.
2. Inform owner that the GVWR and GAWR in VIN Plate unit is pounds.
3. Inform owner that trailer model LCI-830T, LCI-832TA, LCI-850T, LCI-851T trailer's GVWR is 1,170 pounds.
4. Provide "Reporting Safety Defects" statement as a part of owner's manual.
5. We will keep some inventory of "tire placard" and statement sheet at your end for trailer owner request
6. We will provide the tire placard label and statement sheet to our designated agency in one month after your final confirmation.
7. Long Chih Company will remedy that noncompliance without charge.

What should you do?

1. Would you please provide all contact owner's information (trailer manufactured from 9/1, 2005 to 12/31, 2008) to us for sending that information as above mentioned if you handle service by yourself or we send the all information to you then you send to the owner.
2. From Jan.1, 2009 all our trailers were corrected this problem already.

We apologize for any inconvenience for this safety problem may cause, but your safety is our concern.

---

Sincerely Yours,

Long Chih Industrial Company Limited

A handwritten signature in cursive script, appearing to read "Frank Juan".

---

Frank Juan (Managing Director)