

FILE SERVICE: GROUP 00 OF SERVICE INFORMATION BINDER  
PARTS: GROUP 1 OF INFORMATION\_PARTS AND ACCESSORIES BINDER

Campaign No. 2009010002, February 2009

TO: ALL MERCEDES-BENZ CENTERS

SUBJECT: **Model 221, Model Year 2007**  
**Check Both Front ABC Struts,**  
**Replace Front Strut Ball Joints if Necessary**

This Recall Campaign has been initiated because DAG has determined that a defect may exist in the ball joints of the front struts due to a manufacturing process flaw at the supplier. The process flaw may affect the ball joints only after significant mileage accumulation combined with exposure to high continuous stress by driving on rough-roads. If a ball joint fails the steer-ability of the vehicle may be affected which may lead to a vehicle crash. During quality testing, DAG detected a small number of ball joints of the front struts that may not meet Mercedes-Benz long term durability requirements. Supplier investigation led to the identification of a production range which utilized the affected parts.

Prior to performing this Recall Campaign:

- Please check VMI to determine if the vehicle is involved in the Campaign and if it has been previously repaired.
- Please review the entire Recall Campaign bulletin and follow the repair procedure exactly as described.

Please note that Recall and Service Campaigns **do not expire** and may also be performed on a vehicle with a vehicle status indicator.

Approximately 1524 vehicles are involved.

Order No. P-RC-2009010002

This bulletin has been created and maintained in accordance with MBUSA-SLP S423Q001, Document and Data Control, and MBUSA-SLP S424HH001, Control of Quality Records

Recall Campaign Bulletin

Recall Campaign Bulletin

Recall Campaign Bulletin

Recall Campaign Bulletin

**A Check part number and production number on both front ABC struts**

1. Check part number on both ABC struts and write it down on paper:
  - If part number is **not** included in table below procedure is complete (front strut ball joint does not require replacement).
  - If part number is included in table proceed to Step 2.

Part number	Production number
221 320 01 13	05341000191
221 320 02 13	05341000237
221 320 23 13	05353001232
221 320 24 13	05353001250
221 320 65 13	05346000514
221 320 66 13	05347000575
221 320 67 13	05343000272
221 320 68 13	05343000317

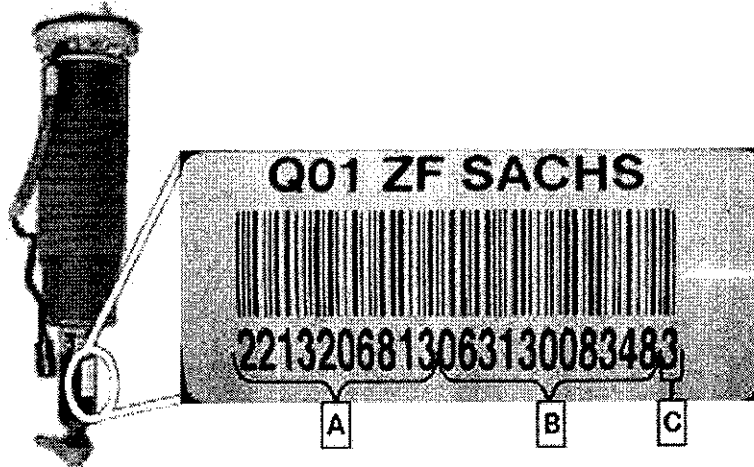
**Figure 1**

2. In the table (above) Check whether the production number is lower than listed in the line of the existing part number:
  - If production number higher than or the same procedure is complete.
  - If production number is lower than listed proceed to Subject B (Replace Both ABC Front Strut Ball Joints).

**Note:**

- **If only one of the of the front strut ball joints requires replacement (as indicated above), replace both front strut ball joints.**
- Disregard the last number (C, Figure 1) when checking the part number (this is a check digit)

## B Replace Both ABC Front Strut Ball Joints

1. Remove wheels.
2. Support lower control arm (A, Figure 3) with under hoist utility stand (B).
3. Disconnect strut ball joint (A, Figure 2) from lower control arm (B, Figure 2) refer to WIS: AR32.25-P-1017SY steps 5 - 6 only.

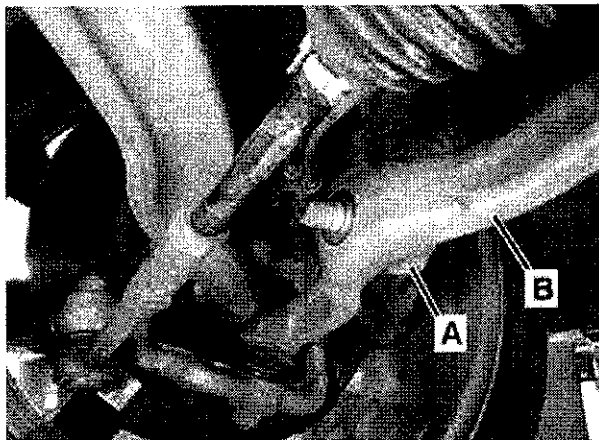

Figure 2

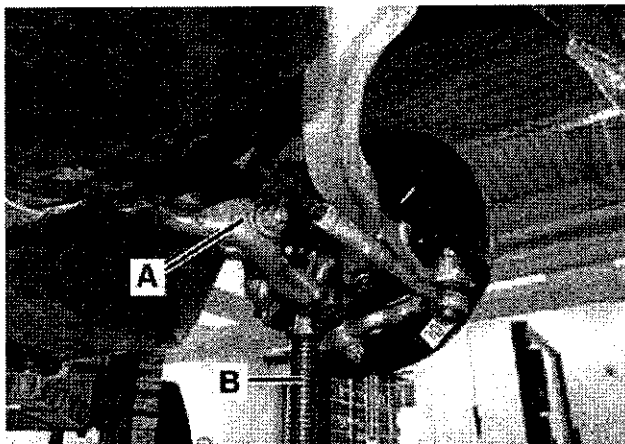

Figure 3

4. Pull ABC strut backward and raise lower control arm (A, Figure 3) upward using under hoist utility stand (B, Figure 3) until ball joint is accessible (Figure 4).

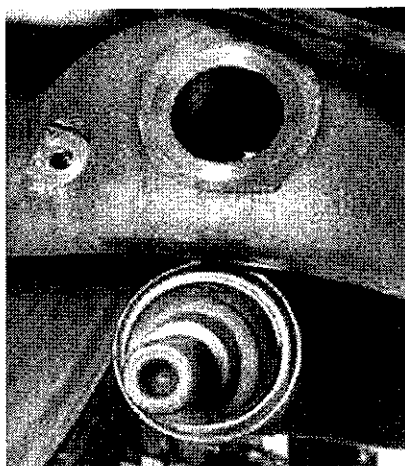

Figure 4

5. Remove ABC strut ball joint from strut:
  - Counter hold ABC strut with open wrench (A, Figure 5) at hexagon and remove ball joint with tool (B) provided in campaign parts kit.

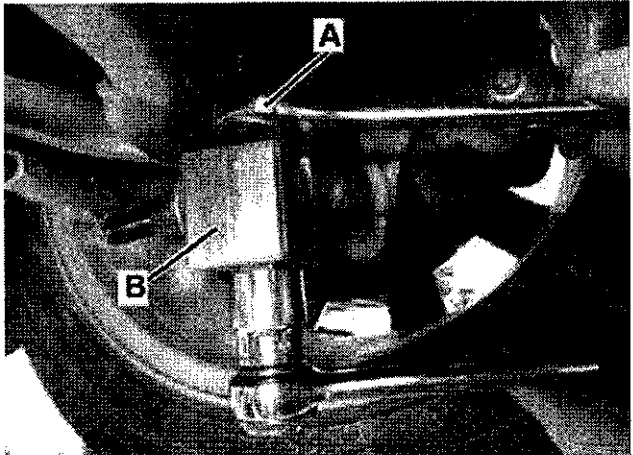

Figure 5

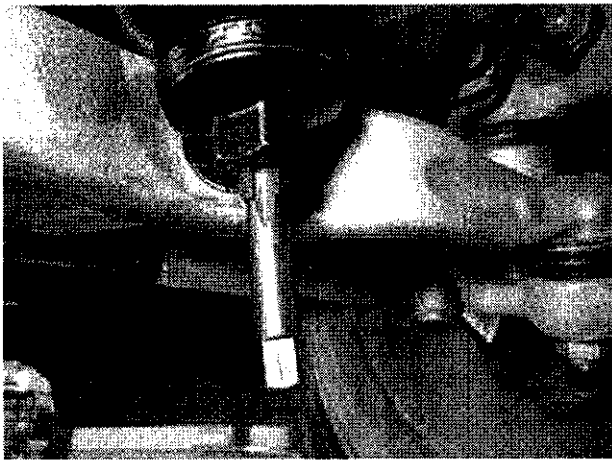

Figure 6

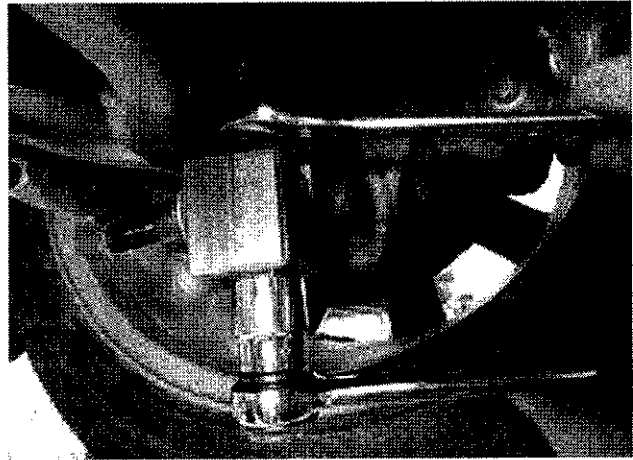

Figure 7

- Clean thread with bottoming tap (Figure 6): M 16x 1.5 mm and remove thread adhesive using compressed air.

**Caution:**

This step must be performed to remove any remaining thread-locking adhesive.

- Install new ball joint using tool (B, Figure 5) provided in campaign parts kit. Torque ball joint to 80 Nm (Figure 7).

**Note:**

When threading ball joint into strut, ensure that no thread locking adhesive remains between strut and ball joint.

**Caution:**

The ball joint installation/removal tool provided must only be used for a **maximum** of 2 ball joint replacements.

6. Align ball joint with suspension strut:
  - Turn ABC strut at lower hexagon with open end wrench (A, Figure 5) so that threaded pin (A, Figure 8) of ball joint points in direction of bore (B) in lower control arm.
  - Ensure that ABC strut boot is not twisted.
7. Complete the reassembly in reverse order of removal.
8. Repeat procedure on opposite side.

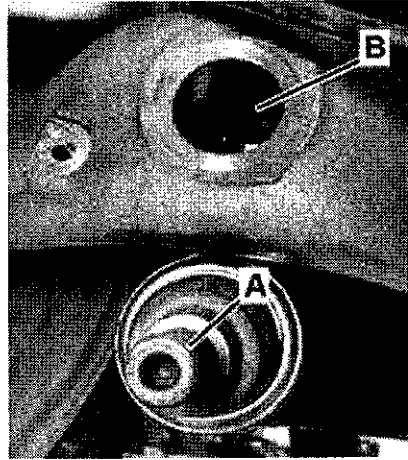
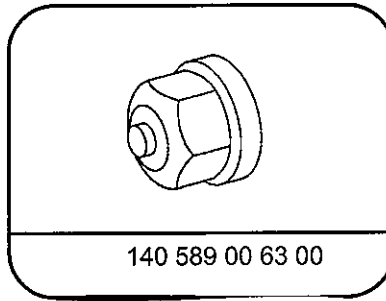
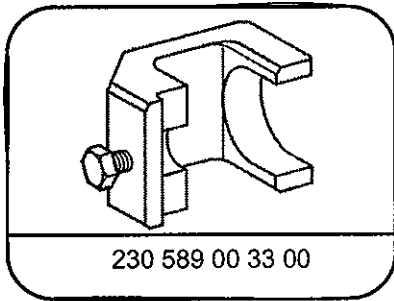

Figure 8

### Special tools



### Parts information

Qty.	Part Name	Part number	Estimated Replacement Rate
1 <sup>1)</sup>	Complete front ABC strut ball joint parts kit	A221 323 00 68 05	30%
2	Nut, suspension strut to spring control arm	N000000 003277	

<sup>1)</sup> Each kit contains 1 tool and 2 ball joints.

**Note:**

- Please be aware that only the part number(s) referenced in the Campaign Bulletin is/are approved for use to repair the vehicle. Repairs performed using any other part(s) will not have been performed in accordance with the campaign. Accordingly, warranty claims submitted with reference to an improper part number(s) will be denied.
- The following allowable labor operation should be used when submitting a warranty claim for this repair:

**Warranty information****Repair 1**

---

**Operation:** Check Both ABC struts (02-6269)

Damage code	Operation Number	Labor Time Est.	Model Indicator(s)
32 950 32 8	02-6269	0.2	AA, AB

**Repair 2**

---

**Operation:** Check Both ABC struts (02-6269)  
Replace Both ABC Strut Ball Joints (02-6271)

Damage code	Operation Number	Labor Time Est.	Model Indicator(s)
32 950 32 7	02-6269	0.2	AA, AB
	02-6271	1.2	

**NOTE REGARDING CUSTOMER REIMBURSEMENT**

Reimbursement to customers for repairs performed prior to this recall:

If the customer already paid to have this recall campaign condition repaired and provides adequate documentation to support their claim of a non-warranty repair of this item, they may be eligible to receive reimbursement.

Requests for reimbursement may include parts, labor, fees and taxes.

Reimbursement is limited to the amount the repair of the strut ball joint(s) would have cost if completed by an authorized Mercedes-Benz dealer under this campaign.

Submit a warranty claim, utilizing Damage Code 32950328 as a sublet, utilizing the sublet code of "SUB." Sublet repairs require dealer text as stated in the Warranty Policies and Procedures Manual. Repair date should be the date that the customer paid for the repair.

**Note:**

Please note the claim submitted for customer reimbursement will **not** close the campaign (if still open). If the customer is still in possession of the vehicle with an open campaign, please arrange to close the campaign in the usual manner as described in this bulletin.