

TO: Winnebago Industries, Inc. Dealers

SUBJECT: Campaign #110 – Adventurer® Limited Windshield Wiper Linkage

The National Traffic and Motor Vehicle Safety Act, as amended, provides that each vehicle which is subject to a recall campaign of this type must be adequately repaired within a reasonable time after the owner has tendered it for repair. A failure to adequately repair within 60 days after tender of a vehicle is prima facie evidence of failure to repair within a reasonable time.

If the condition is not adequately repaired within a reasonable time, the owners may be entitled to an identical or reasonably equivalent vehicle at no charge or to a refund of the purchase price less a reasonable allowance for depreciation.

To avoid having to provide these burdensome solutions, every effort must be made to promptly schedule an appointment with each owner and to repair their vehicle as soon as possible. As you will see in reading the enclosed copy of the letter which is being sent to owners, the owners are being instructed to contact Winnebago Industries, Inc. if you do not remedy the condition within five days of the mutually agreed upon service date. If the condition is not remedied within a reasonable time, they are instructed on how to contact the National Highway Traffic Safety Administration.

REASON FOR THIS RECALL

Winnebago Industries, Inc. has decided a defect which relates to motor vehicle safety exists where the windshield wipers may fail to operate properly. Inoperative wipers under inclement weather conditions could cause impaired visibility which has the potential to result in personal injury and/or vehicle and property damage.

OWNER NOTIFICATION

Owners will be notified of this campaign on their vehicles by Winnebago Industries, Inc. For all units in your inventory, the notification will be mailed to you. **DO NOT DELIVER TO A CUSTOMER ANY SUBJECT UNIT UNTIL CORRECTIVE ACTION HAS BEEN TAKEN.** Enclosed is a list of vehicles shipped to you.

DEALER CAMPAIGN RESPONSIBILITY

Dealers are to service all vehicles subject to this campaign at no charge to owners regardless of mileage, age of vehicle, or ownership from this time forward.

Whenever a vehicle subject to this campaign is taken into new or used vehicle inventory or it is in your dealership for service in the future, you should take the steps necessary to be sure the campaign correction has been made before reselling or releasing the vehicle. Owners of vehicles recently sold from your new vehicle inventory are to be contacted by the dealer and arrangements made to make the required correction according to instructions contained in this campaign.

INSTRUCTION TO PERFORM CAMPAIGN #110

Affected Models:

The motor vehicles potentially containing the defect are on certain 2008 model year Winnebago Adventurer Limited motor homes built prior to May 3, 2008.

Repair Procedure:

Refer to instruction sheet for inspection and replacement of the windshield wiper linkage.

Parts Information:

To minimize any inconvenience to your customers, we strongly encourage you to promptly order part kits for the stock vehicles on the attached list. This will ensure you have adequate inventory for your customers. Order the following part kit from Winnebago Industries[®] using the WIN NET system. You will be placing the order as a recall order. You will need the recall dealer number and the Winnebago Industries serial number of the affected vehicle to place the order.

Dealer Number: 7680

<u>Quantity</u>	<u>Part Description</u>	<u>Winnebago Industries Part Number</u>
1	Wiper Link Arm Kit	RC7680-09-710
1	Instruction Sheet	

REIMBURSEMENT

When the service has been completed, submit the labor amount and labor operation number listed below. Your repair order must be properly signed by both the dealer and the owner.

	<u>OPERATION NUMBER</u>	<u>TIME ALLOWANCE</u>
INSPECTION OF WINDSHIELD WIPER LINKAGE	24100101	.4 hr.
--OR--		
REPLACEMENT OF WINDSHIELD WIPER LINKAGE	24100201	.6 hr.

Thank you for your cooperation.

Winnebago Industries, Inc.
Forest City, Iowa 50436

RP123/5

Enclosures



INSTRUCTIONS TO PERFORM CAMPAIGN 110

Models Affected:

Selected 2008 model year Winnebago Adventurer Limited motor homes manufactured before May 3, 2008.

Tools Required:

- Pry Bar
- Channel Lock
- 9/16 Socket
- 9/16 Wrench
- Torque Wrench
- Personal Safety Glasses

Kit Includes:

- New driver and passenger wiper link arms
- Instructions

Procedure:

The windshield wiper motor and bracket assembly have been installed in a position that could allow the wiper arm to bind and not work properly. This recall process involves inspecting, and if necessary, replacing the existing wiper link arms with updated wiper link arms.

1. Open front hood by pulling top of hood latch outward (located in front driver's side compartment) to release hood panel. Gas props will allow the top of the hood panel to swing outward and lower slowly until fully open. See Photos A and B.



2. With another person operating the wipers from inside the coach, confirm that the driver and passenger side pivot assemblies operate within the suggested range as shown below. See Photo C.

NOTE: If the driver and passenger side pivot assemblies are operating out of the suggested range, proceed with the following instructions.

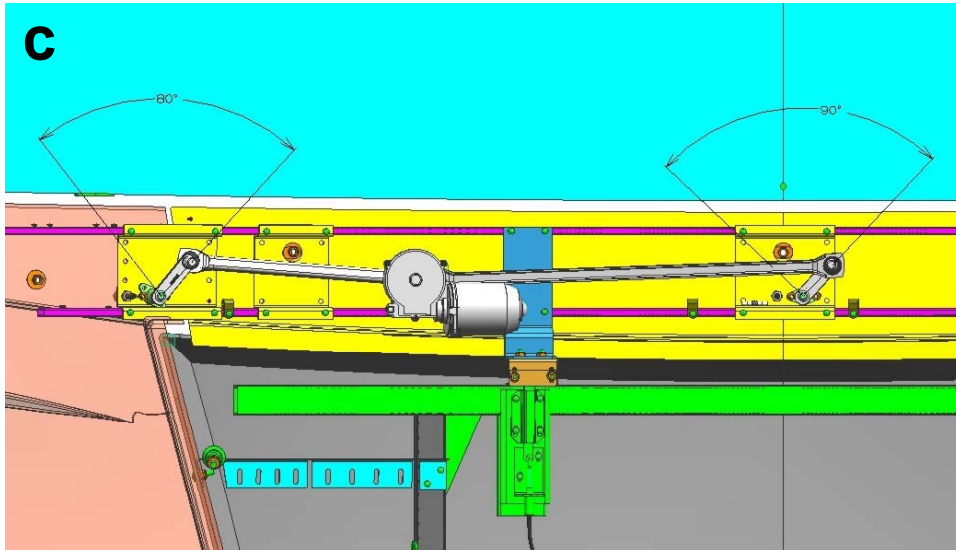

3. Remove driver and passenger side wiper arms. See Photo D.



4. Remove wiper link arm from ball stud on the pivot assemblies at the driver and passenger side wipers by using a pry bar. See Photo E.



5. Remove driver and passenger side wiper link arm from the ball stud at the motor drive arm by using a pry bar. See Photo F.

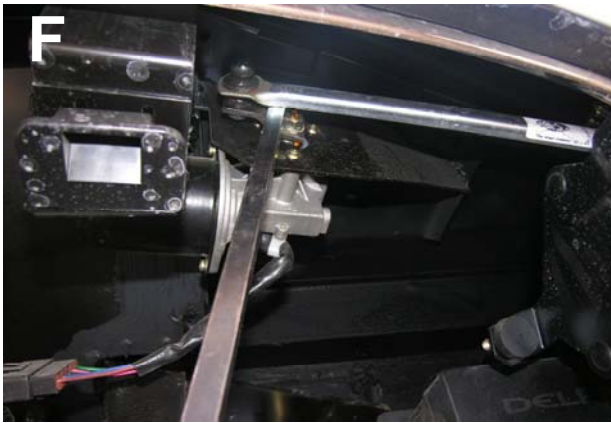

- Using a channel lock pliers, install the driver side wiper link arm (the shorter link) first on the driver side pivot assembly and then to the inside ball of the wiper motor drive arm. See Photo G.

Install the passenger side wiper link arm (the longer link) first to the outside ball of the wiper motor drive arm and then to the passenger side pivot assembly. See Photo H.

NOTE: If the ball stud is dry, apply a small amount of multipurpose grease to ease installation.



- Start the engine and cycle the wiper motor making sure to allow the wiper motor to come to a stop in the “park” position prior to turning off the engine.
- Check to assure the wiper motor drive arm is at a 9 o'clock position. Shown in Photo I.

NOTE: If the wiper motor drive arm is not at a 9 o'clock position, repeat Steps 7 and 8.

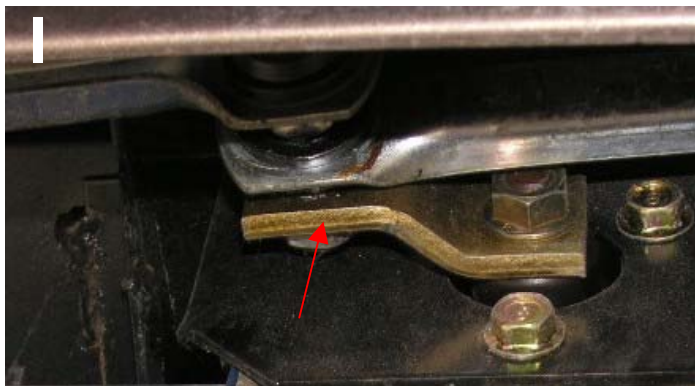

9. With another person operating the wipers from inside the coach, confirm that the driver and passenger side pivot assemblies operate within the suggested range as shown below. See Photo J.

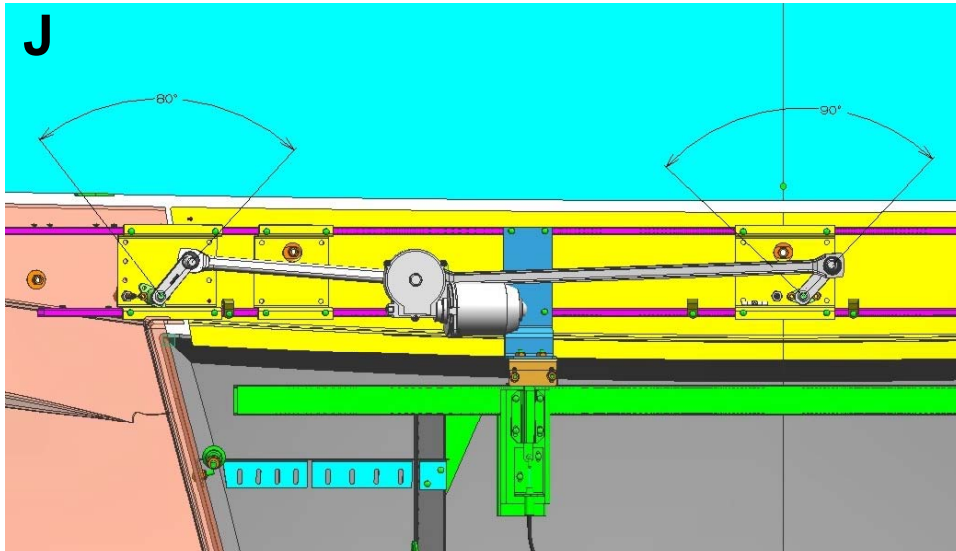

10. Close hood gently and push top of hood inward firmly with both palms outstretched to latch.
11. Reinstall driver and passenger side wiper arms on the pivot assemblies. Shown in Photo K.

NOTE: Each notch on the spline shaft is 6 degrees. See Photo L.



12. Torque wiper arms to 13 ft.-lbs.

13. Spray the windshield with water, start the engine, and cycle the wiper system several times while engaging the windshield wipers. Turn the wipers off allowing them to stop at the “park” position. Stop the engine and assure that the wipers “park” in a level position. See Photo M.

M



14. If the wipers do not park in a level position, remove the wiper arms from the pivot assemblies and reposition on the splined shafts. Repeat Step 11 until the windshield wipers “park” in a level position. Retorque wiper arms to 13 ft.-lbs.