

# VOLKSWAGEN

GROUP OF AMERICA

MARIA COTTER NAME  
LEAD CAMPAIGN ADMINISTRATOR TITLE  
PRODUCT COMPLIANCE DEPARTMENT  
248-754-5000 PHONE  
248-754-5093 FAX  
SEPTEMBER 25, 2008 DATE

Ms. Patricia Wallace  
Recall Analyst for Safety Assurance  
National Highway Traffic Safety Administration  
Attn: Recall Management Division (NVS-215)  
U.S. Department of Transportation  
1200 New Jersey Avenue, S.E.  
Washington, DC 20590

VOLKSWAGEN GROUP OF AMERICA, INC.  
3800 HAMLIN ROAD  
AUBURN HILLS, MI 48326  
PHONE +1 248 754 5000

**Subject: Recall Campaign 08V-397 (37D5/J2)**

Dear Ms. Wallace:

Pursuant to the requirements set forth in Part 573.6 of Title 49 of the Code of Federal Regulations, we are submitting three (3) copies of the following communications for recall campaign 08V-397 (37D5/J2):

- Dealer notification letter
- Work Procedure and Claiming Instructions

If you have any questions or require additional information, please contact me.

Sincerely,



Maria Cotter  
Lead Campaign Administrator  
Product Compliance -Service and Quality  
Enclosures

Audi of America, Inc.



## SAFETY RECALL INFORMATION

September 2008

Audi of America, Inc.  
3800 Hamlin Road  
Auburn Hills, MI 48326  
United States of America  
[www.audiusa.com](http://www.audiusa.com)

**Subject: Campaign Announcement – Safety Recall 37D5/J2**

Dear Audi Dealer Principal, Service Manager, and Parts Manager:

This is to inform you of Safety Recall 37D5/J2 on 1996-2003 MY Audi A8 with 5-speed automatic transmission.

### **What is the problem?**

The affected vehicles equipped with a 5-speed automatic transmission have a locking cable that may move out of position over time. With the locking cable out of position, the shifter can be moved out of the PARK position even if the ignition key is not in the ignition lock. This could allow the vehicle to roll, causing a crash without warning.

### **What does the repair involve and when will the repair be available?**

Audi will modify the automatic transmission locking cable by installing an adjusting piece that will secure the locking cable in place. This work will be done at no cost to customers. Customer notification will begin on or about September 26, 2008.

### **Parts Allocation Information**

You will receive an initial allocation of parts for this campaign prior to the initiation of this safety recall.

### **Important Reminder on Vehicles Affected by Safety and Compliance Recalls**

Federal law prohibits any person from knowingly selling, or offering for sale, any motor vehicle that either contains a defect related to motor vehicle safety or does not comply with applicable motor vehicle safety standards prescribed under Chapter 301 (“Motor Vehicle Safety”) of Title 49, United States Code. It is therefore imperative that you correct any vehicle in your inventory that is affected by this recall **prior to delivery** for sale or lease.

Claims should be submitted on the day of the repair, if possible. This will close out the campaign on the vehicle and help prevent another dealer from performing the same repair if the vehicle goes to another dealership.

### **Where to Find Complete Campaign Information**

Please refer to **Safety Recall 37D5/J2** posted in ElsaWeb and ServiceNet for additional information, and please be sure to share this information with all personnel with campaign-related responsibilities.

Thank you for your help in this matter.

Audi Product Compliance

### IMPORTANT INFORMATION

Please inform and provide a copy of this document to every person in your dealership with campaign-related responsibilities, including Service, Parts and Accounting personnel. By law, dealers must correct, prior to delivery for sale or lease, any vehicle that fails to comply with an applicable Federal Motor Vehicle Safety Standard or that contains a defect relating to motor vehicle safety. If you have questions regarding this or any other campaign, please call (800) 741-2919.



# Safety Recall Circular

Code: **37D5/J2**

**Subject: 1996-2003 Audi A8 with 5-speed Automatic Transmission  
Automatic Transmission Locking Cable Modification**

September 2008

### Problem Description

The affected vehicles equipped with a 5-speed automatic transmission have a locking cable that may move out of position over time. With the locking cable out of position, the shifter can be moved out of the PARK position even if the ignition key is not in the ignition lock. This could allow the vehicle to roll, causing a crash without warning.

### Corrective Action

Audi will modify the automatic transmission locking cable by installing an adjusting piece that will secure the locking cable in place.

### VIN Range and Production Date of Affected Vehicles

#### (USA)

#### 1996-2003 A8

WAU\_\_4D\_TN001280 - WAU\_\_4D\_3N002826  
Produced July 19, 1995 - August 14, 2002

#### (CANADA)

#### 1997-2003 A8

WAU\_\_4D\_VN000205 - WAU\_\_4D\_3N002789  
Produced July 23, 1996 - August 08, 2002

**NOTE:** Check ElsaWeb on the day of repair to verify vehicle eligibility and attach the screen print to the repair order. This is the only valid campaign inquiry and verification source. Some vehicles may be involved in an additional action(s); any additional work can be done while the vehicle is in for this action.

### Allocation Report of Affected Vehicles

In the Service Manager's Package, dealers with affected vehicles will receive a report containing the VIN, customer name, city, state and zip code. Dealers will not receive a report if they have no affected vehicles.

### Parts Information and Allocation

Prior to owner notification, parts will be allocated to all dealers. Ensure that these parts are inventoried in a secure manner and are used ONLY for this campaign.

If you have exhausted your allocated parts for vehicles affected by this safety recall, but have exceeded your weekly Upper Order Limit, please submit your requests for additional material via email to [upperorderlimits@audi.com](mailto:upperorderlimits@audi.com). If you have questions regarding parts please contact the Parts Helpline at 800-767-6552.

### Owner Notification Mailing

On or about September 26, 2008, Audi will notify all known owners of affected vehicles by first class mail. A sample copy of the owner letter is enclosed.

### Claim Entry Procedure

Immediately upon completion of the repair work, enter the Applicable Criteria ID and Repair Operation(s) from the chart below. **The Applicable Criteria ID is shown in ElsaWeb.** Claims will only be paid for vehicles that show this campaign open in ElsaWeb on the day of the repair. To help ensure prompt and proper payment, attach the screen print to the repair order.

### **Saga Claim Entry Procedure**

Check ELSAWeb to determine whether the "37D5" campaign is open.

**Service No.:** 37D5

**Damage Code:** 0099

**Parts Manufacturer**

Removed part: Use vendor code 002.

#### Claim Type

Sold vehicle = 7 10

Unsold vehicle = 7 90

#### Criteria ID: 4D

Inspect automatic transmission cable; update already present, no further work required

**Repair operation: 01 83 00 99      20 TU**

**- OR -**

Inspect and modify automatic transmission cable.

**Repair operation: 37 10 55 99      50 TU**

Repair Kit (1) 4D0 998 998 B

**There is NO reimbursement for Vehicle Wash or Loaner**

#### If Customer Refuses Repairs:

Fax the Repair Order to Campaign Team at (248) 754-5093. Provide the VIN, applicable Service Number, customer information, Dealer number, and date.

## Customer Letter Example (United States)

September 2008

Subject: Safety Recall 37D5/J2  
1996-2003 Audi A8 with 5-speed Automatic Transmission  
Automatic Transmission Locking Cable Modification

Dear Audi Owner:

This notice is sent to you in accordance with the requirements of the National Traffic and Motor Vehicle Safety Act. Audi has decided that a defect, which relates to motor vehicle safety, exists in some 1996-2003 model year Audi A8 vehicles equipped with a 5-speed automatic transmission. Our records show that you are the owner of one of these vehicles.

### What is the issue?

Audi has decided that the affected vehicles have an automatic transmission locking cable that may move out of position over time. With the locking cable out of position, the shifter can be moved out of the PARK position even if the ignition key is not in the ignition lock. This could allow the vehicle to roll, causing a crash without warning.

### What Will Audi Do?

In order to correct this defect, we will modify the automatic transmission locking cable by installing an adjusting piece that will secure the locking cable in place.

### What We Would Like You to Do

Please contact your authorized Audi dealer and arrange for an appointment without delay. This service will take approximately one hour and will be free of charge. Please keep in mind that your dealer may need additional time for the preparation of the repair, as well as to accommodate their daily workshop schedule.

### Lease Vehicles

If you are the lessor and registered owner of the vehicle identified in this letter, the law requires you to forward this information via first class mail to the lessee within 10 days of receipt of this notification.

### Have You Changed Your Address Or Sold The Vehicle?

If you have, please fill out the enclosed prepaid Owner Reply card and mail it to us so we can update our records.

### Reimbursement of Expenses

If you have previously paid for repairs to the automatic transmission locking cable, the enclosed form explains how to request reimbursement. We would be pleased to review your reimbursement request.

### Service Help from Us

If your authorized Audi dealer fails or is unable to complete this work free of charge within a reasonable amount of time, please call or write to:

*Audi of America, Inc.  
Attn: Customer Relations (37D5/J2)  
3499 West Hamlin Road  
Rochester Hills, MI 48309  
1-800-253-2834*

If you still cannot obtain satisfaction, you may file a complaint with: Administrator, National Highway Traffic Safety Administration, 1200 New Jersey Avenue S.E., Washington, DC 20590; or call the toll-free Vehicle Safety Hotline at 1-888-327-4236 (TTY: 1-800-424-9153), or go to <http://www.safercar.gov/>.

We regret any inconvenience this matter may cause. Thank you for your continued loyalty!

Audi Product Compliance

The information in this document is intended for use only by skilled technicians who have the proper tools, equipment and training to correctly and safely maintain your vehicle. These procedures are not intended to be attempted by "do-it-yourselfers," and you should not assume this document applies to your vehicle, or that your vehicle has the condition described. To determine whether this information applies, contact an authorized Audi dealer. ©2008 Audi of America, LLC and Audi of Canada, Inc. All Rights Reserved.

## Customer Letter Example (Canada)

September 2008

Subject: Safety Recall 37D5/J2  
1997-2003 Audi A8 with 5-speed Automatic Transmission  
Automatic Transmission Locking Cable Modification

Dear Audi Owner:

This notice is sent to you in accordance with the requirements of the Canadian Motor Vehicle Safety Act. Audi has decided that a defect, which relates to motor vehicle safety, exists in some 1997-2003 model year Audi A8 vehicles equipped with a 5-speed automatic transmission. Our records show that you are the owner of one of these vehicles.

### What is the issue?

Audi has decided that the affected vehicles have an automatic transmission locking cable that may move out of position over time. With the locking cable out of position, the shifter can be moved out of the PARK position even if the ignition key is not in the ignition lock. This could allow the vehicle to roll, causing a crash without warning.

### What Will Audi Do?

In order to correct this defect, we will modify the automatic transmission locking cable by installing an adjusting piece that will secure the locking cable in place.

### What We Would Like You to Do

Please contact your authorized Audi dealer and arrange for an appointment without delay. This service will take approximately one hour and will be free of charge. Please keep in mind that your dealer may need additional time for the preparation of the repair, as well as to accommodate their daily workshop schedule.

### Lease Vehicles

If you are the lessor and registered owner of the vehicle identified in this letter, the law requires you to forward this information via first class mail to the lessee within 10 days of receipt of this notification.

### Have You Changed Your Address Or Sold The Vehicle?

If you have, please fill out the enclosed prepaid Owner Reply card and mail it to us so we can update our records.

### Reimbursement of Expenses

If you have previously paid for repairs to the automatic transmission locking cable, the enclosed form explains how to request reimbursement. We would be pleased to review your reimbursement request.

### Service Help from Us

If your authorized Audi dealer fails or is unable to complete this work free of charge within a reasonable amount of time, please call or write to:

*Audi Canada  
Attn: Customer Relations (37D5/J2)  
P.O. Box 842, Stn. A  
Windsor, ON N9A 9Z9  
1-800-253-2834*

We look forward to providing this service for you. Thank you for your continued loyalty!

Audi Product Compliance

The information in this document is intended for use only by skilled technicians who have the proper tools, equipment and training to correctly and safely maintain your vehicle. These procedures are not intended to be attempted by "do-it-yourselfers," and you should not assume this document applies to your vehicle, or that your vehicle has the condition described. To determine whether this information applies, contact an authorized Audi dealer. ©2008 Audi of America, LLC and Audi of Canada, Inc. All Rights Reserved.

If there are questions regarding the work procedure, contact the Campaign Helpline at 1-800-741-2919.

**Parts:**

<u>Quantity</u>	<u>Part Number</u>	<u>Part Name</u>
1	4D0 998 998 B	Parts kit, consisting of: <ul style="list-style-type: none"> <li>• Adjusting pieces (4), 4D0713299 B, C, D, &amp; E</li> <li>• Clamping piece, 4D0 713 358</li> <li>• Bolt, N 090 364 5</li> </ul>

**Work Sequence**

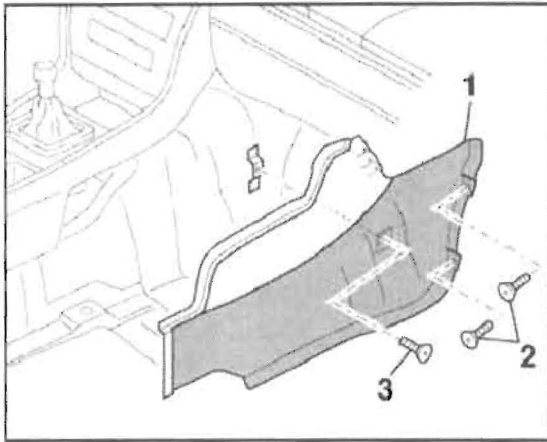



**Section A – Locking Cable Inspection**

- ⇐ Remove carpet (front right) and right side trim of center console -1-
- ⇐ Remove bolts -2- (below floor covering) and -3-
- Slide trim forward and unhook at rear
- Take hold of front end of air duct for rear cabin ventilation (located behind side trim for center console) and push it aside slightly
- ⇐ Inspect locking cable for presence of adjusting piece -arrow- (part number 4D0713299 B, C, D, or E)
- If adjusting piece (part number 4D0713299 B, C, D, or E) is present, install parts in reverse order; **WORK IS COMPLETE**
- If adjusting piece (part number 4D0713299 B, C, D, or E) is not present, **proceed to Section B**

The information in this document is intended for use only by skilled technicians who have the proper tools, equipment and training to correctly and safely maintain your vehicle. These procedures are not intended to be attempted by "do-it-yourselfers," and you should not assume this document applies to your vehicle, or that your vehicle has the condition described. To determine whether this information applies, contact an authorized Audi dealer. ©2008 Audi of America, LLC and Audi of Canada, Inc. All Rights Reserved.

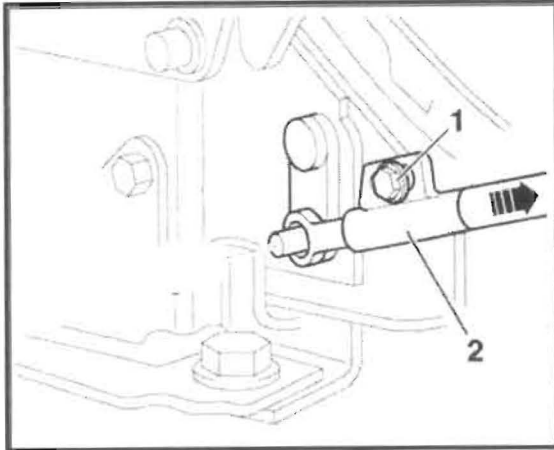
## Section B – Locking Cable Modification





 Tip: Locking cable is attached to shift unit (bottom part of selector lever unit) and can be accessed through opening in center console

← Remove bolt -1-

 Tip: Bolt is not re-used

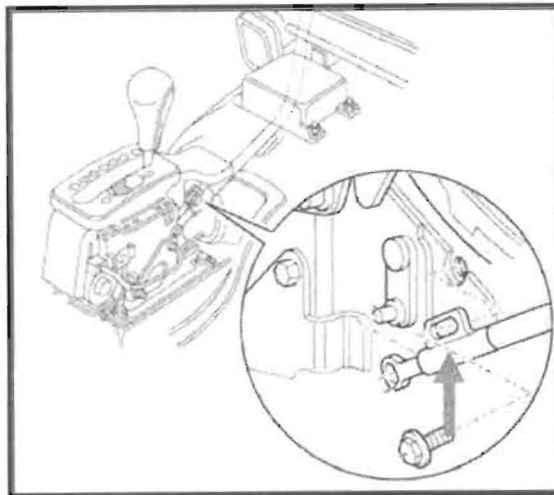
← Disengage locking cable -2-



 Tip: Elongated hole –arrow- will no longer be used for locking cable adjustment

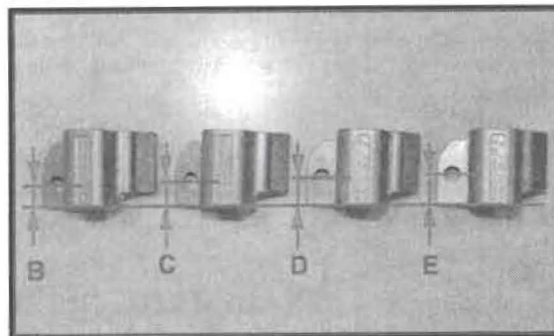

 Tip: One of four adjusting pieces (part number 4D0713299 B, C, D, or E) with different hole alignments will now be used instead of elongated hole.

To determine the correct adjusting piece, try each one until the best fitting piece is matched

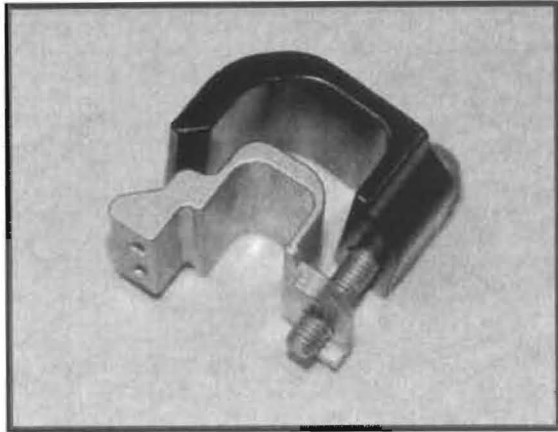



 Tip: The ignition key must be removed

 Tip: To find the proper adjusting piece, start with index B from previous picture

⇐ Insert new bolt (N 090 364 5) through black clamping piece (4D0 713 358) and adjusting piece (4D0713299 B, C, D, or E) as shown

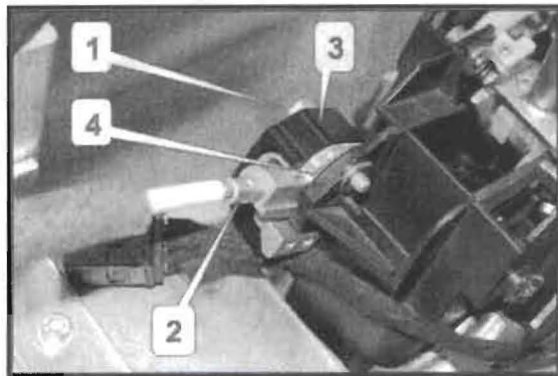
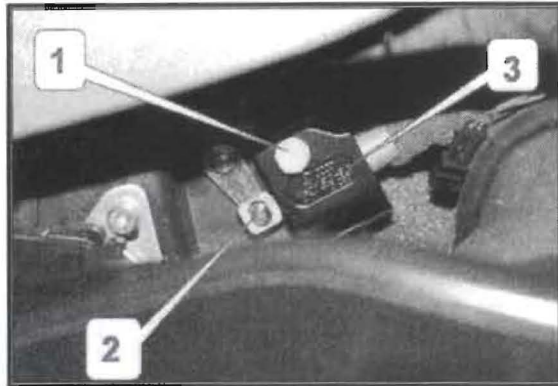
⇐ Attach locking cable -2- and secure clamping piece -3- by tightening bolt -1-



 Tip: Photo shows selector lever unit removed and serves to illustrate fitting locations:

- 1- Bolt M6
- 2- Locking cable
- 3- Clamping piece
- 4- Adjusting piece

#### Checking ignition key removal lock:

- With selector lever in Park "P", switch ignition on
- Press brake pedal and move selector lever to "D" and back to "P"
- Switch off ignition and remove key

 Tip: If ignition key cannot be removed freely, repeat adjustment procedure with next adjusting piece



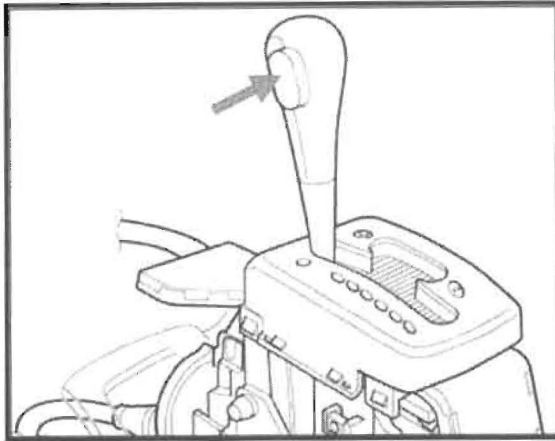

### Checking selector lever lock:

- Switch off ignition and remove ignition key
- ⇐ It should not be possible to press interlock button –arrow- so far in that selector lever can be moved out of position “P”.
- ⇐ If selector lever can be moved out of “P”, repeat procedure with next adjusting piece



Tip: Locking effect decreases with each adjusting piece in alphabetical order (example: 4D0713299 B => C=> D=> E)

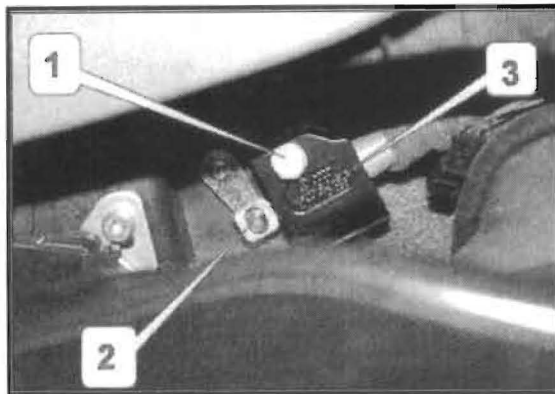

### Applying locking fluid:

- Once proper adjusting piece is identified, remove bolt -1- again, coat with locking fluid Part No. D 000 600 A2 (shop supply) and torque to 10Nm
- Install parts in reverse order
- Properly dispose of remaining parts from parts kit

## WORK IS COMPLETE