



Applies To: **2008 Element 2WD** – From VIN 5J6YH1...8L013895 thru 5J6YH1...8L013924  
**2008 Element 4WD** – From VIN 5J6YH2...8L014984 thru 5J6YH2...8L015673

**August 13, 2008**

### Safety Recall: Left Rear Trailing Arm May Come Loose

(Supersedes 08-053, dated July 25, 2008, to update the information marked by the black bars)

#### BACKGROUND

The left trailing arm of the rear suspension may have been improperly welded and could separate from its front mount. A separated trailing arm would cause the lower half of the left rear wheel to pivot outward. This could damage the left rear brake line and may cause a possible loss of vehicle control, which could lead to a crash.

#### CUSTOMER NOTIFICATION

Affected vehicle owners were contacted by phone. The vehicle owners were instructed not to drive the vehicle, and to contact their local Honda dealer to have the vehicle towed in for repair. Those customers who could not be reached by phone were sent a notification of this campaign. An example of the customer notification is at the end of this service bulletin.

Only 241 vehicles within the affected VIN ranges are potentially affected by this campaign. To verify vehicle eligibility, you **must** check at least one of these items:

- The customer received a phone call from AHM.
- The customer has a notification letter.
- The vehicle is shown as eligible on a VIN status inquiry.

In addition, check for a punch mark above the first character of the engine compartment VIN. A punch mark in that location means this campaign has already been completed.

Some vehicles affected by this campaign may be in your new vehicle inventory. These vehicles must be inspected and, if needed, repaired before they are sold or leased. Should an unrepaired vehicle cause an injury or damage because of the recalled item, the dealership will be solely responsible to the damaged party, and will be required to defend and indemnify American Honda for any resulting claims. To see if a vehicle is affected by this campaign, do a VIN status inquiry before selling or leasing it.

#### CORRECTIVE ACTION

Inspect the welding date code stamped into the left trailing arm:

- If the code is NROX 1, replace the left trailing arm and its attaching bolts and nuts.
- If the code is not NROX 1, a new left trailing arm is not needed. Center-punch a campaign completion mark above the 1st character of the engine compartment VIN.

#### PARTS INFORMATION

Left Trailing Arm:

P/N 52371-SCV-A02, H/C 8396202

Self-Locking Nut (10 mm):

P/N 90212-SA5-003, H/C 1169812

Flange Bolt (14 x 77) (2 required):

P/N 90396-SCV-A00, H/C 8401150

Flange Bolt (12 x 73) (2 required):

P/N 90399-S5A-000, H/C 6463020

Flange Bolt (14 x 87):

P/N 90398-SCV-A00, H/C 8401176

Flange Lock Nut:

P/N 90395-SNA-003, H/C 8178568

Adjusting Bolt:

P/N 52387-S5A-000, H/C 6455513

#### WARRANTY CLAIM INFORMATION

OP#	Description	FRT	Template ID
418501	Inspect the left trailing arm.	0.2	08-053A
4181C5	Inspect and replace the left trailing arm.	1.5	08-053B
C	Add 4-wheel alignment.	0.6	

Failed Part: P/N 52371-SCV-A02  
H/C 8396202

Defect Code: 5RT00

Symptom Code: Q8900

Skill Level: Repair Technician



**CUSTOMER INFORMATION:** The information in this bulletin is intended for use only by skilled technicians who have the proper tools, equipment, and training to correctly and safely maintain your vehicle. These procedures should not be attempted by "do-it-yourselfers," and you should not assume this bulletin applies to your vehicle, or that your vehicle has the condition described. To determine whether this information applies, contact an authorized Honda automobile dealer.

## INSPECTION PROCEDURE

1. Raise the vehicle on a lift, and remove the left rear wheel.
2. Check the date code stamped on or near the bottom of the front lower mount of the left trailing arm:
  - If the date code is NROX 1, go to REPAIR PROCEDURE.
  - If the date code is not NROX 1, go to step 3.

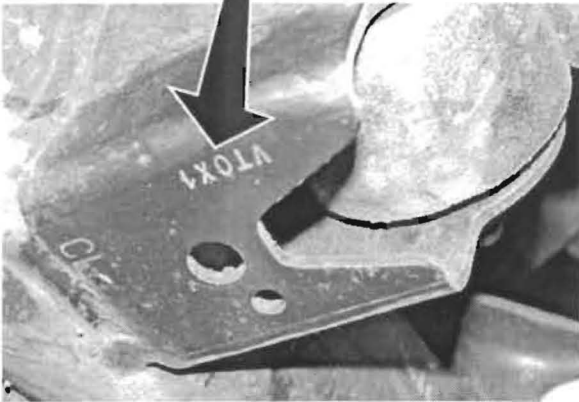

3. Reinstall the left rear wheel, and torque its bolts to **108 N·m (79.6 lb-ft)**.
4. Center-punch a completion mark above the first character of the engine compartment VIN.

Center-punch here.

**5J6YHXXXXXXXXXXXX**

## REPAIR PROCEDURE

1. Place a floor jack under the left trailing arm to support it.
2. Remove the flange lock nut, the adjusting cam, the adjusting bolt, and the flange bolt from the lower mount of the knuckle. The nut and the bolts will not be reused.

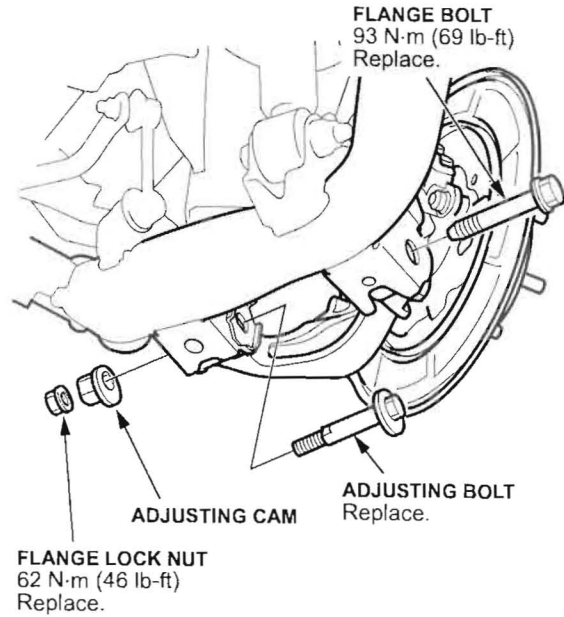

3. Remove the flange nut from the stabilizer link, then detach the stabilizer link from the trailing arm. The nut will not be reused.

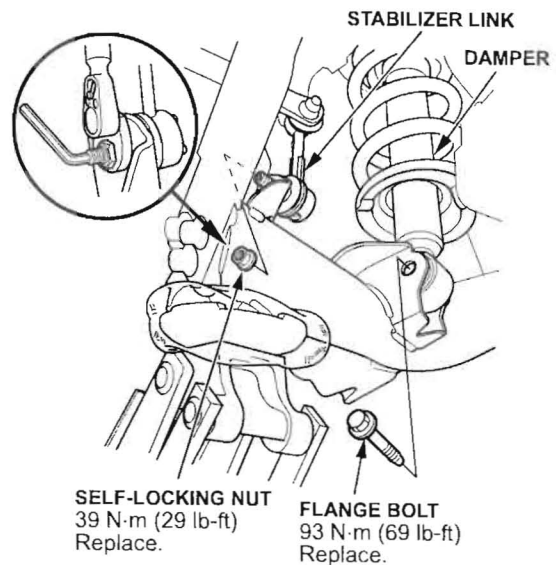

4. Remove the flange bolt from the lower mount of the damper, then detach the damper from the trailing arm. The bolt will not be reused.

- Remove the two flange bolts from the front mount of the trailing arm, then remove the trailing arm bushing guard. The bolts will not be reused.

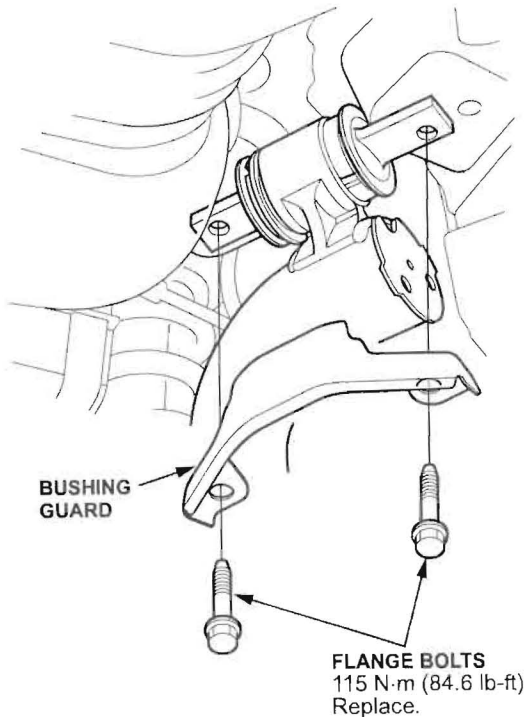

- Remove the flange bolt from the rear mount of the trailing arm. The bolt will not be reused.

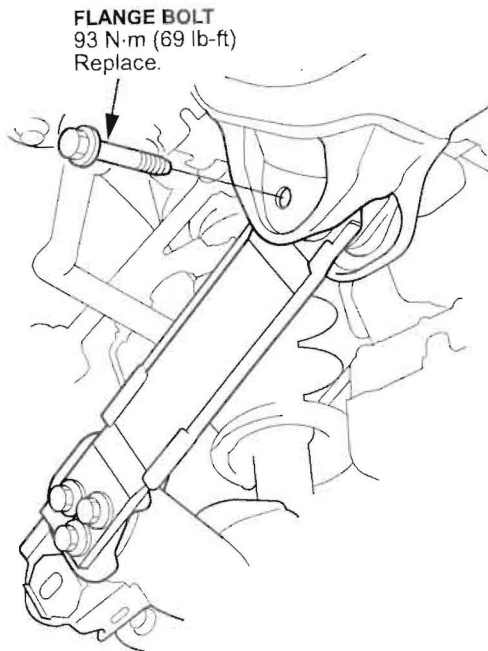

- Lower the floor jack, and remove the trailing arm.

- Install a new left trailing arm in the reverse order of removal, using new nuts and bolts as described in the removal steps.

**NOTE:** To install the trailing arm, lightly tighten the nuts and bolts, then place a jack under the arm, raise the suspension to load it with the vehicle's weight, and tighten the nuts and the bolts to the torque values shown in the illustrations.

- Reinstall the left rear wheel, and torque its bolts to **108 N·m (79.6 lb-ft)**.
- Do a four-wheel alignment:
  - Refer to pages 18-5 thru 18-8 of the *2007–2008 Element Service Manual*, or
  - Online, enter keyword **ALIGN**, and select **Wheel Alignment** from the list.
- Center-punch a completion mark above the first character of the engine compartment VIN.

Center-punch here.

**5J6YHXXXXXXXXXXXX**

#### Example of Customer Letter

Summer 2008

### Safety Recall: Left-Rear Trailing Arm May Come Loose

Dear Element Owner:

This notice is sent to you in accordance with the requirements of the National Traffic and Motor Vehicle Safety Act.

#### What is the reason for this notice?

Honda Motor Co., Ltd., has decided that a defect related to motor vehicle safety exists in certain 2008 model year Element vehicles. The left trailing arm of the rear suspension may have been improperly welded and could separate. A separated trailing arm would cause the lower half of the left rear wheel to pivot outward. This could damage the left rear brake line and may cause a possible loss of vehicle control, which could lead to a crash.

#### What should you do?

Please stop driving your vehicle immediately, and call any authorized Honda dealer to have your vehicle taken to a Honda dealer. The dealer will inspect the left rear trailing arm, and replace it if needed. This work will be done *free of charge*. Please plan to leave your vehicle for at least one day to allow the dealer flexibility in scheduling.

#### Who to contact if you experience problems.

If you are not satisfied with the service you receive from your Honda dealer, you may write to:

American Honda Motor Co., Inc.  
Automobile Customer Service  
Mail Stop 500-2N-7A  
1919 Torrance Blvd.  
Torrance, CA 90501-2746

If you believe that American Honda or the dealer has failed or is unable to remedy the defect in your vehicle, without charge, within a reasonable period of time (60 days from the date you first contact the dealer for a repair appointment), you may submit a complaint to:

Administrator  
National Highway Traffic Safety Administration  
1200 New Jersey Avenue, S.E.  
Washington, DC 20590

You can also call the toll-free Safety Hotline at 888-327-4236 (TTY 800-424-9153), or go to <http://www.safercar.gov>.

**What to do if you feel this notice is in error.**

Our records show that you are the current owner or lessee of a 2008 Element potentially affected by this campaign. If this is not the case, or the name/address information is not correct, please fill out and return the enclosed, postage-paid Information Change Card. We will then update our records.

**Lessor information.**

Federal law requires that any vehicle lessor receiving this recall notice must forward a copy of this notice to the lessee within 10 days.

**If you have questions.**

If you have any questions about this notice, or need assistance with locating a Honda dealer, please call Automobile Customer Service at 800-999-1009.

We apologize for any inconvenience this campaign may cause you.

Sincerely,

**American Honda Motor Co., Inc.**  
**Honda Automobile Division**