



YAMAHA MOTOR CORPORATION, USA
6555 KATELLA AVENUE, CYPRESS, CALIFORNIA 90630-5101 714/761-7300

May 21, 2008

VIA FACSIMILE (202) 366-7882, Attn: Associate Administrator
ALSO VIA FIRST CLASS MAIL

Associate Administrator for Safety Assurance (NVS-215)
National Highway Traffic Safety Administration
1200 New Jersey Avenue, SE
West Building
Washington, DC 20590

Regarding: 08V-180

Dear Sir/Madam,

First, we thank the Agency for their review and approval of our proposed owner's notification. Enclosed please find hard copies of the Technical Bulletin issued to our dealers as well as the approved owner's letter. All Yamaha motorcycle and scooter dealers will receive this Technical Bulletin. To facilitate repairs, dealers invoiced affected products under this recall receive an additional Bulletin with a print-out of the affected VIN's for the units they have received. The mailing of both the dealer Bulletin and owner's letter was completed approximately on 5-9-08, so your assumption is correct as to the timing of our quarterly reports.

The determination date for this campaign was 4-10-08. The starting production period for the vehicles was July, 2004, ending in April, 2007. As this campaign is international in scope we could only provide in our initial report an estimate of affected vehicles in the U.S. We are now obviously in a position to provide the accurate range. The Technical Bulletin provides the final VIN ranges by model with a combined total of 10,040 vehicles in the U.S. (1,629 CP250's and 8,412 YP400's). For TREAD purposes obviously it goes without saying similar campaigns are being conducted in other jurisdictions.

In the event I can provide further information or answer any questions please do not hesitate to contact the undersigned.

Sincerely,

A handwritten signature in black ink, appearing to read "Brad Franklin", written over a white background.

Brad Franklin
Department Manager
Government Relations

BF/Imf

Enclosures: Technical Bulletin
Owners Letter

Technical BULLETIN

©2008 YAMAHA MOTOR CORPORATION, U.S.A.

RECALL

This modification has top priority. This bulletin must be performed immediately to ensure customer safety.

2006~2007 CP250 (Morphous); 2005~2007 YP400 (Majesty) FACTORY MODIFICATION CAMPAIGN – Fuel Pump Harness

i

INTRODUCTION

Yamaha Motor Corporation, U.S.A., has determined that a defect which relates to motor vehicle safety exists in all 2006 and certain 2007 CP250 (“Morphous”) and all 2005, 2006, and certain 2007 YP400 (“Majesty”) scooters. In affected scooters, the engine could stall and be difficult to restart because the wire terminals in the fuel pump wire coupler have corroded. This is because water can enter from the main wire harness end and run through the harness to the fuel pump coupler. If the water remains in the coupler for an extended period of time, the terminals can become corroded, which can prevent the fuel pump from operating properly. If this corrosion affects fuel pump operation while the scooter is being ridden, there could be an accident resulting in injury or death.

To correct this defect, Yamaha is initiating a Factory Modification Campaign. Affected scooters must have a sub-harness installed which is designed to allow any water between the wire harness and the fuel pump to drain out before it reaches the fuel pump. If either the main wire harness connector or the fuel pump connector is already corroded, the corresponding assembly(ies) must also be replaced.

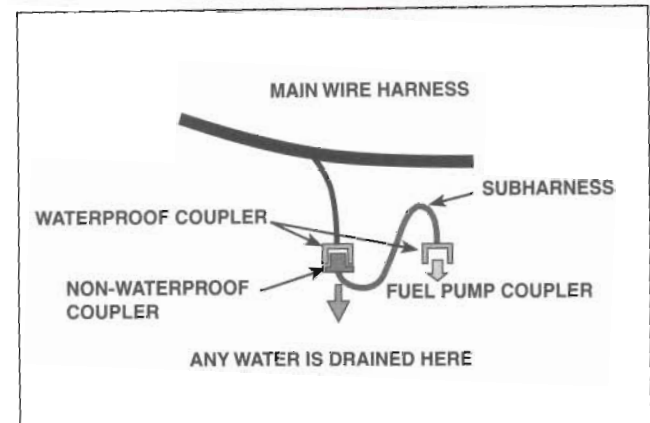
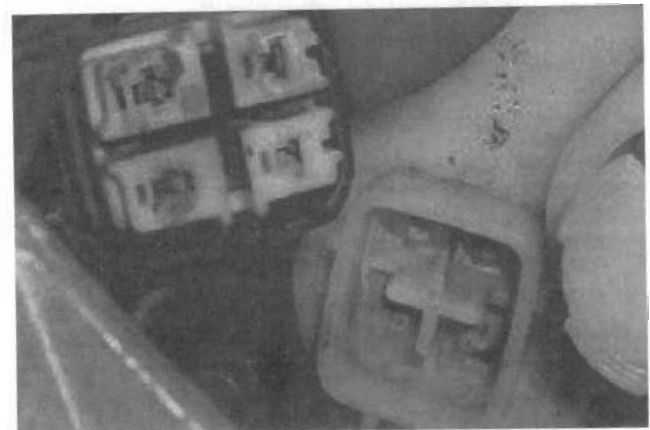

This is the same problem and correction procedure announced in Technical Bulletin M2007-012A. Due to the possibility of stalling as well as hard starting, the 90-code procedure is now a recall. If an affected unit already had the modification described in M2007-012A and the 90UA claim was filed, no additional action is necessary now. The previously described modification satisfies this recall. Effective immediately, Service-Per-Bulletin code 90UA is expired and is replaced by the recall campaign number 990047. Please make a note on Technical Bulletin M2007-012A to refer to this bulletin instead.

NOTE: The service procedure involves use of a special terminal removal tool that was mailed with Technical Bulletin M2007-012A. Contact your Regional Technical Advisor (RTA) if you do not have the special tool from the earlier mailing.

Yamaha is notifying all registered owners of affected scooters by mail, except those with units already modified and claimed with the Service-Per-Bulletin 90UA. A copy of this letter is included in this bulletin. The customer should take the letter along with the affected scooter to an authorized Yamaha dealer for the modification.

A computer report listing all affected scooters invoiced to your dealership is included with this bulletin. Use the list to help ensure all scooters are modified. All sold scooters that have been registered with Yamaha will show the customer's name and address. Your dealership must notify the owner of any affected scooter that was actually sold but is listed as "unsold" in the report.

You must modify all affected scooters in your inventory as well as all customer-owned scooters brought to you for this service. Any affected scooter that you purchase from Yamaha in the future will also require modification. If you purchase a scooter from another dealer, check to see if the procedures in this bulletin have already been performed before you sell the scooter.

Scooters that are affected should not be operated until they are modified. It is a violation of Yamaha policy for your dealership to deliver any affected scooters to customers until the procedures in this bulletin are performed.

When the modification on each scooter is performed, follow the Warranty Information section of this bulletin to receive reimbursement. Be sure to use the Factory Modification Campaign procedures in Chapter 8 of the Warranty and Y.E.S. Handbook (LIT-11790-00-05).



DEALER ACTION SUMMARY

Modify: All units in the affected range that were not already modified according to the procedures described in M2007-012A. Before modifying a unit, check for a punch mark on the VIN as shown in the Identification Procedure section of this bulletin which indicates that the required modification has already been performed.

Parts

Required: Yes, order one Fuel Pump Sub-harness Kit per unit.

Warranty: Factory Modification Campaign. See the Warranty Information section of this bulletin. Units which had Service-Per-Bulletin 90UA claimed from M2007-012A will automatically be updated in Yamaha's warranty records to show that this recall modification was performed.

Notify

Customers: Yes. You must immediately contact any customer whose scooter shows as unregistered on the enclosed report. Yamaha has sent letters to customers whose scooters were registered for warranty as of 5/5/08.



AFFECTED RANGE

2006 CP250V	SG18Y-0000009~0001188
2007 CP250W	SG18Y-0001189~0001706
2005 YP400T	SH03Y-0000009~0002523
2006 YP400V	SH03Y-0002524~0004573
2007 YP400W	SH03Y-0004574~0007611

NOTE: Units in the affected range already modified according to the instructions in Technical Bulletin M2007-012A do not need any further modification. The modification this bulletin describes is identical to that earlier bulletin.



SERVICE PROCEDURES

NOTE: A special terminal remover tool was mailed with Technical Bulletin M2007-012A. This tool is to be used when removing any terminals from the fuel pump wire connector during this service procedure. If this tool is lost or misplaced, contact your Regional Technical Advisor (RTA) for a replacement tool.

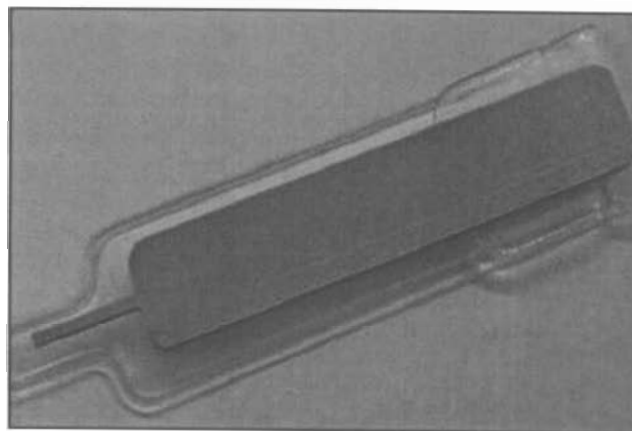

YP400 SERVICE PROCEDURE

1. Open the seat. Remove the felt liner from the storage compartment.
2. Remove the upper rear panel by pushing in the center pin of the plastic reusable rivets that are located inside the under-seat storage at the back.

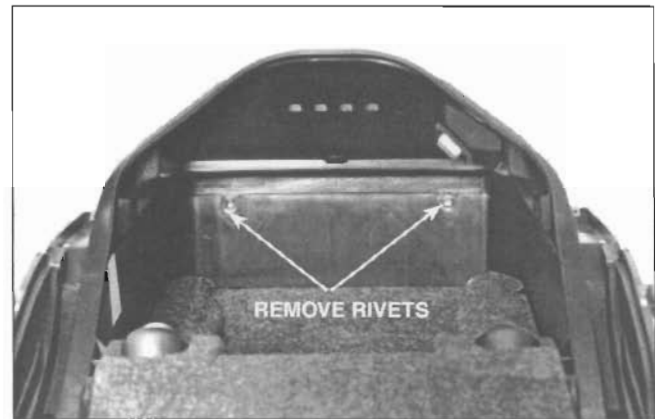
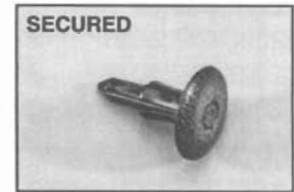

3. Grip the upper rear panel firmly and pull towards the rear and up until it unsnaps from the side panels.

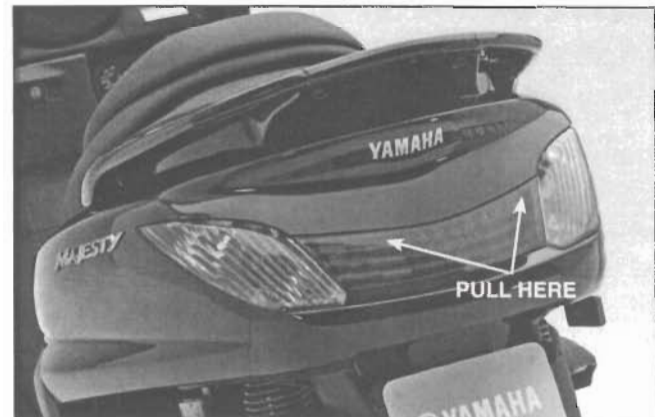

4. Remove the Allen screw (6mm) and then remove the passenger seat.

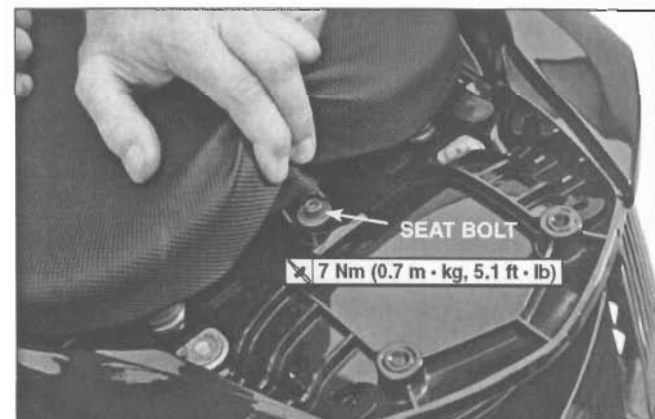

YP400 SERVICE PROCEDURE (CONT'D)

5. Remove the 2 screws underneath the top panel and then remove the panel.

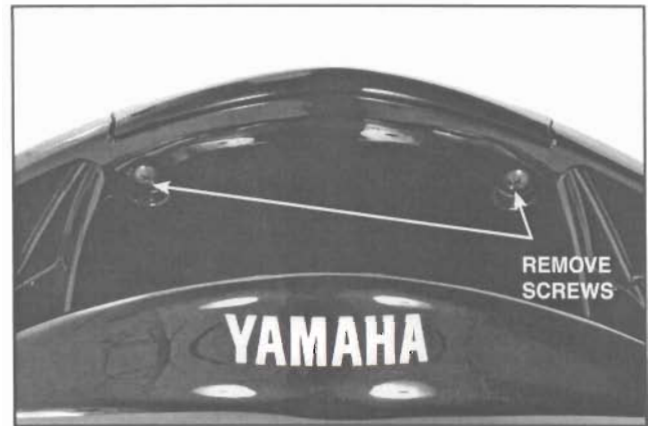

6. Remove 4 Allen head bolts and then remove the grab rail.

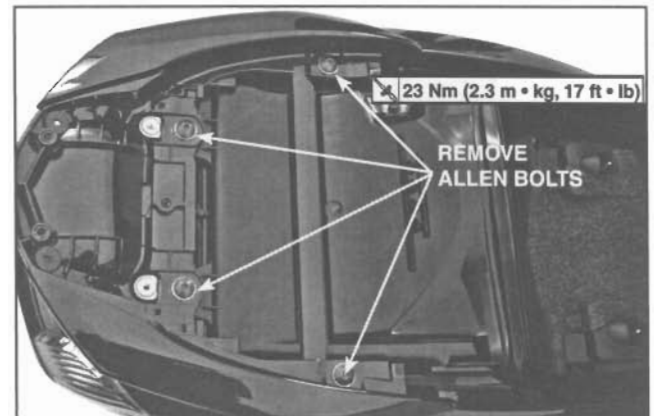

7. Remove screws from each side of the lower panel and then remove the panel.

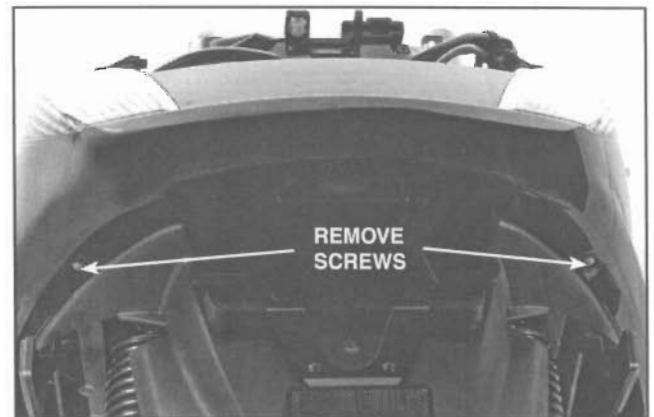

YP400 SERVICE PROCEDURE (CONT'D)

8. To remove the middle side panel, first remove the small cover and rubber foot mats on the panel.

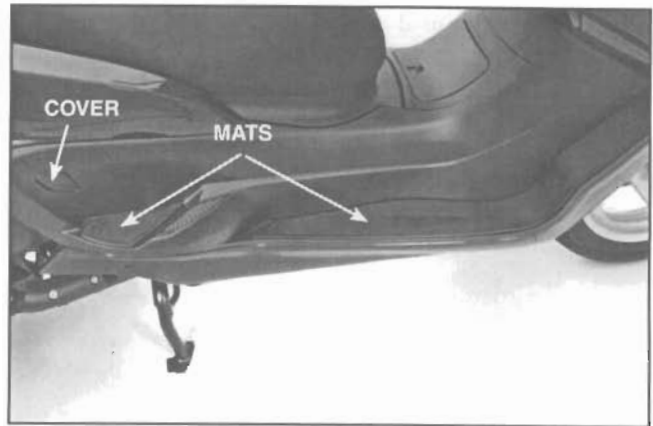

Remove the 4 screws and then pull up on the panel to remove it. Repeat on the other side.

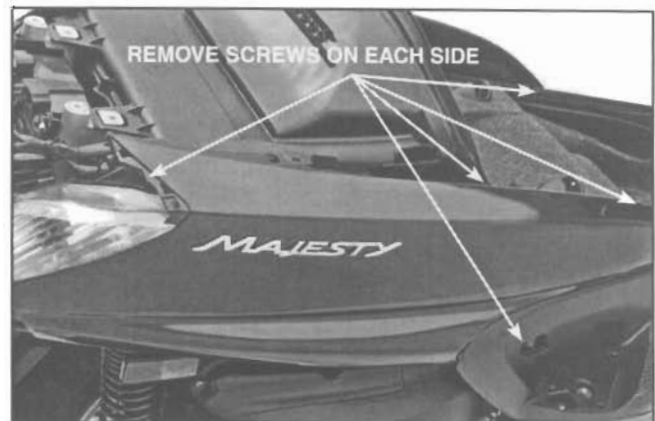

YP400 SERVICE PROCEDURE (CONT'D)

9. To remove the lower footboard panel, remove 3 screws from the top of the panel and the one on the bottom front. Remove the panel. Repeat for the other side.

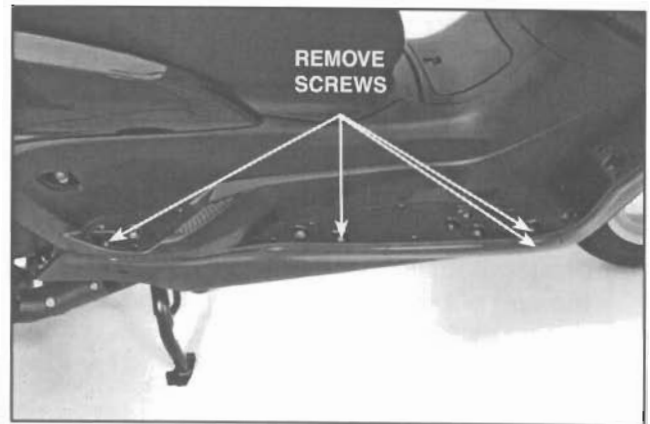

10. To remove the fuel filler cover, first open the cover. Remove the fuel cap. Remove the cover screws and then remove the cover.

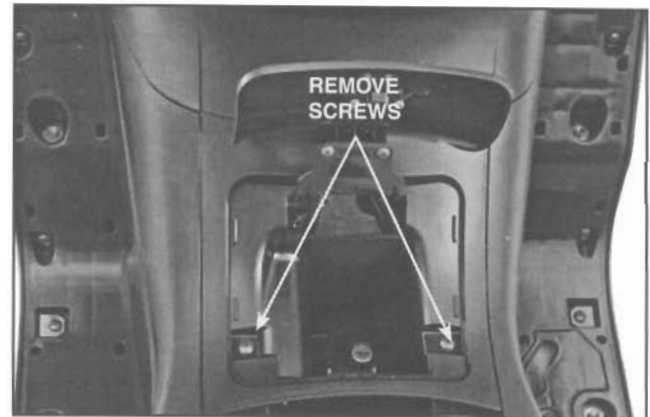

11. To remove the seat assembly, first remove the 4 Allen head bolts under the seat and remove the seat cushion.

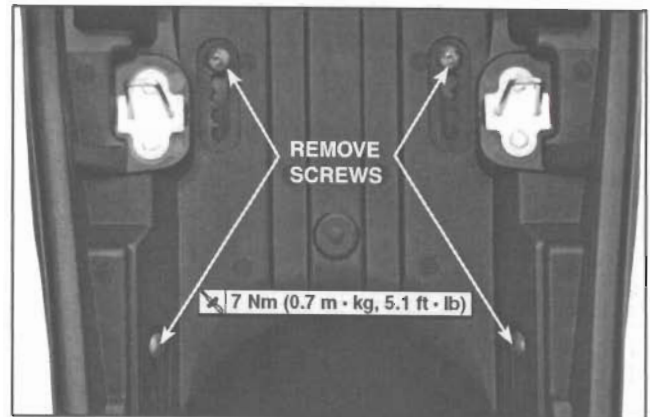

Then, remove the 6 screws on the top of the seat base and remove the cover.

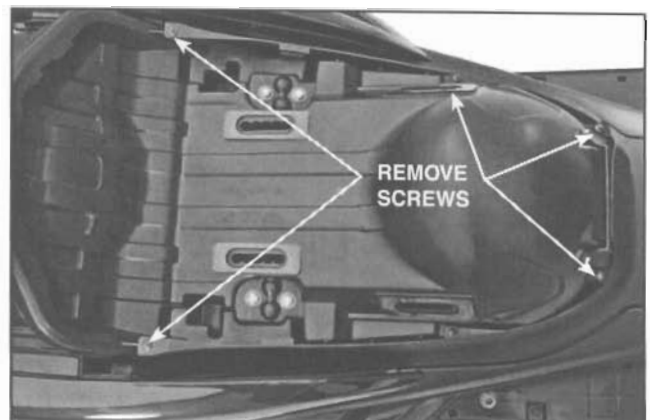

YP400 SERVICE PROCEDURE (CONT'D)

Finally, remove the clip from the hydraulic seat prop and remove the prop from its post. Remove the two 8mm Allen bolts and remove the seat.

IMPORTANT: Note how the seat bracket assembly is constructed. When reassembling, open the seat slightly more than the fully open position to allow installation of the hydraulic seat support. Also, make sure that the end of the hydraulic seat support is reinstalled as it was before.

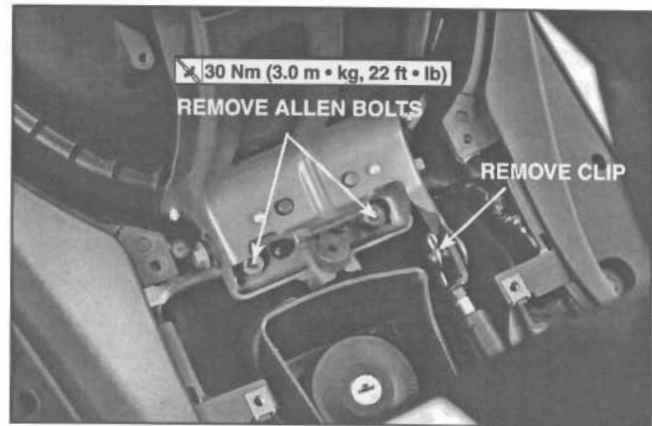

12. To remove the middle side panels:

- Remove the 4 bolts (6mm): three on the front floorboard and one on the rear.
- Remove 4 screws at the front of the floorboard and one on the top in the middle.
- Remove 2 screws on each side of the fuel filler.
- Pull the rear of the panel outward and then back to remove the panel.

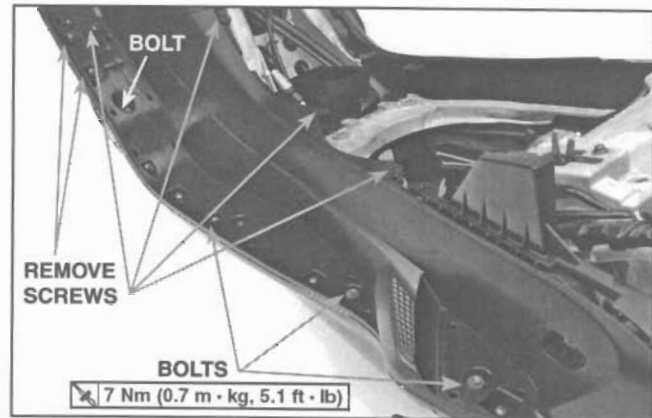

13. To remove the storage compartment, first remove the 2 bolts (8mm) that hold each grab rail mount, then remove the mounts.

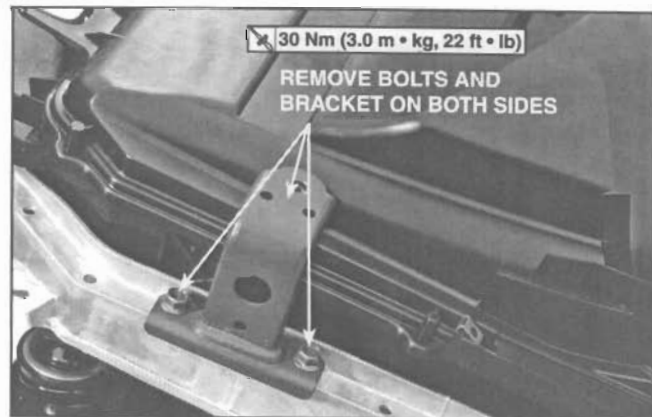

Remove the 4 shouldered bolts (6mm) from the front and center of the compartment.

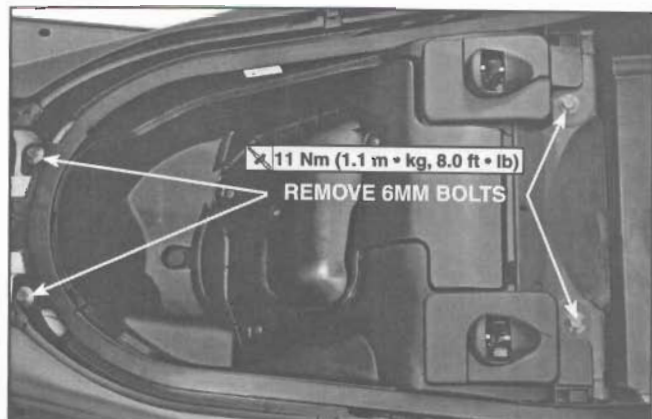

YP400 SERVICE PROCEDURE (CONT'D)

Unplug the compartment light. Lift the compartment up and unhook the starter relay and fuse box from their holders. Slide a small straight blade screwdriver between the holder and the backside of the fuse box to release it. Remove the storage compartment.

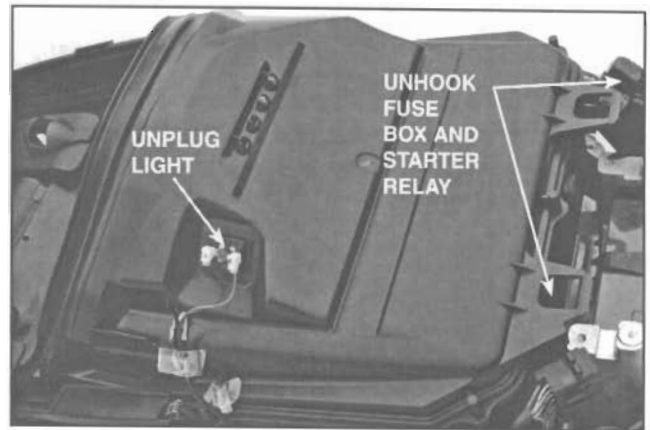

14. Remove the main wire harness coupler from the fuel pump.
15. Inspect the terminals on the harness connector and on the fuel pump. If there is corrosion, replace the main wire harness and/or fuel pump as necessary. Refer to the Service Manual (LIT-11616-18-38) for wire-harness replacement. For tips on replacing the fuel pump, see the procedures given in Technical Bulletin M2007-011R which covers fuel pump seal replacement. If the coupler is wet, but not corroded, dry it with compressed air.

NOTE: If the procedures in Technical Bulletin M2007-011R have not been performed, do them now.



YP400 SERVICE PROCEDURE (CONT'D)

Sub-harness Installation

1. Using the wide end of the special terminal removal tool, remove the coupler inner cover and rear cap.

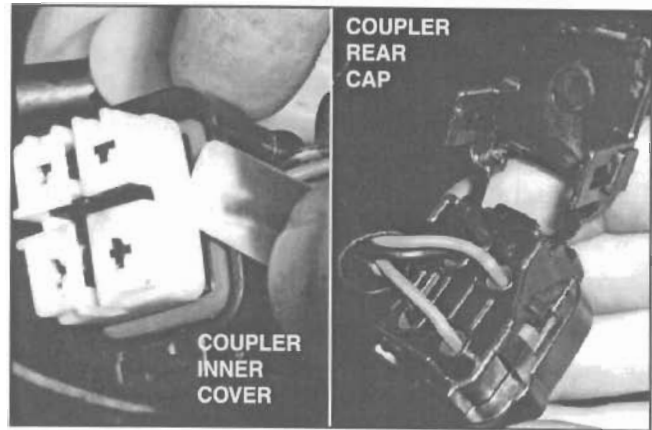

2. Using the narrow end of the terminal removal tool, remove the terminals from the fuel pump wire coupler of the main wire harness.
3. Remove the coupler inner cover from the new coupler as described in step 1 on the previous page.

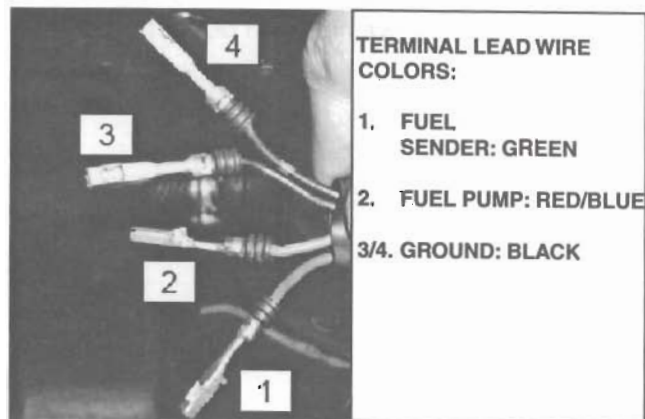
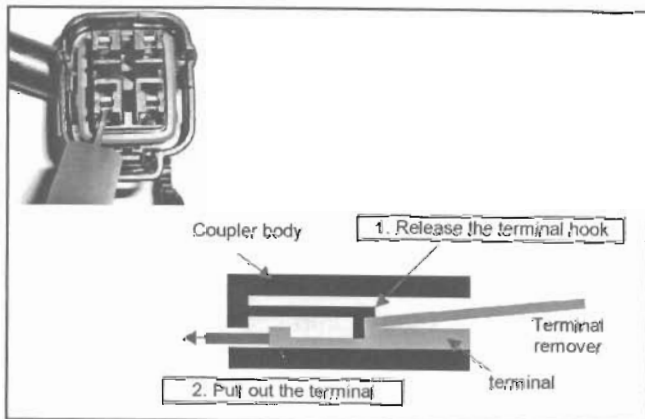

YP400 SERVICE PROCEDURE (CONT'D)

4. Install the wire terminals into the new coupler in the position described below. Make sure to push the terminal into the terminal slot all the way until it clicks. If the terminal is inserted in the wrong direction, it cannot be inserted all the way. Reinstall the inner cover.

NOTE: Either black lead wire terminal can be inserted into either black-labeled slot.

Terminal Lead Wire	Green	Red/Blue	Black	Black
Color of Terminal Slot Label on New Coupler	Green	Red	Black	Black

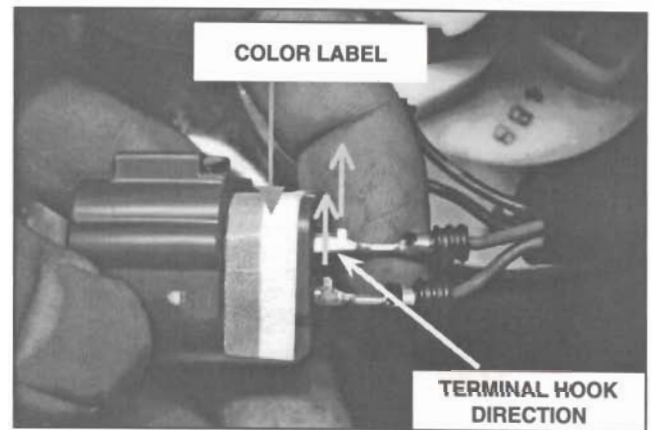

5. Install the fuel pump sub-harness. Plug one end of the fuel pump sub-harness into the coupler modified in step 4 above and the other into the fuel pump.

YP400 SERVICE PROCEDURE (CONT'D)

6. Secure the fuel pump sub-harness with the supplied plastic bands (zip ties) as shown.

CAUTION:

Be sure to secure the fuel pump sub-harness as shown. This positions the wire harness coupler of the main wire harness in a position that will allow any water that enters the wire harness to drain out.

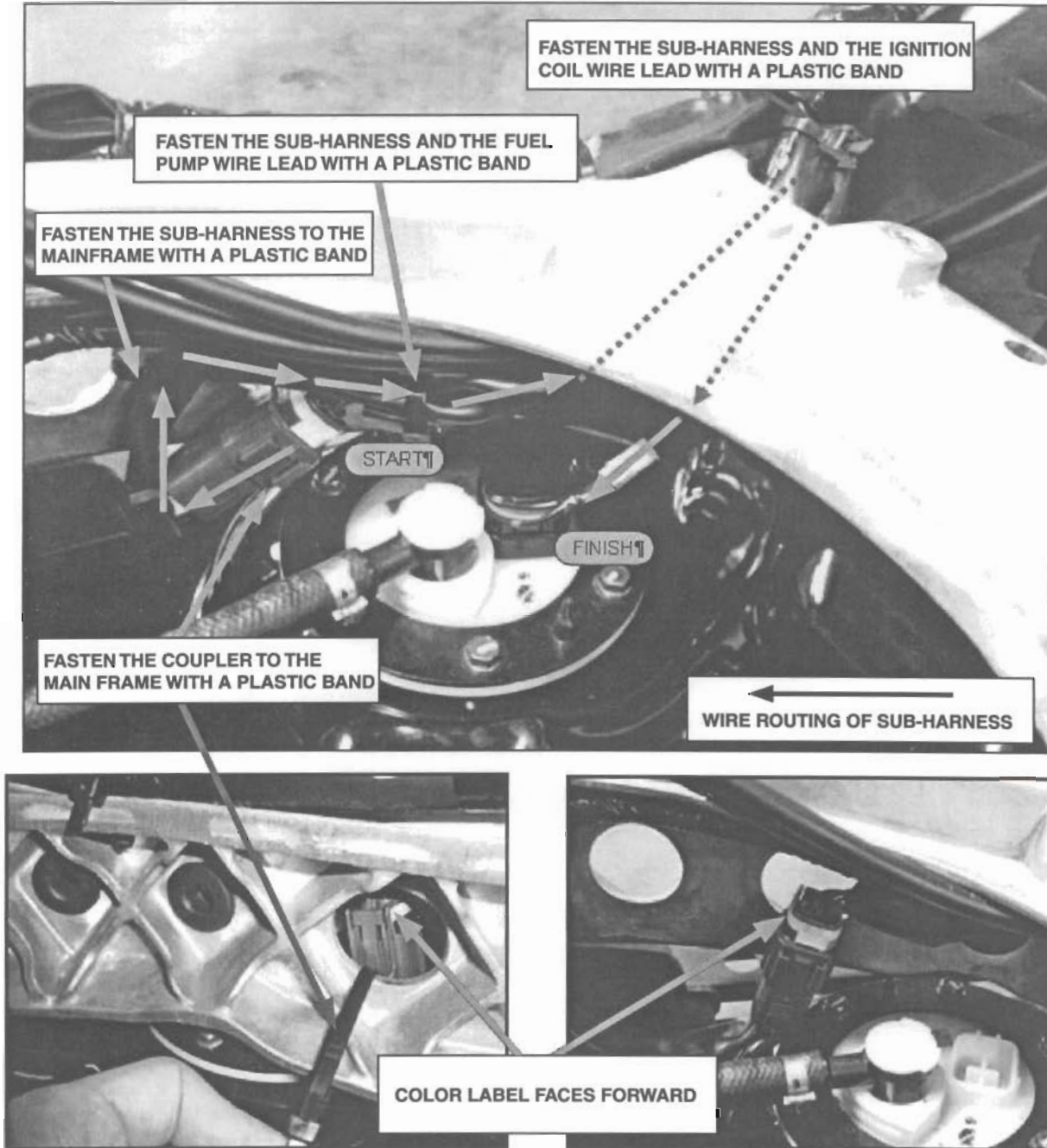

7. After starting the engine to confirm that the fuel pump operates correctly, reassemble the scooter in the reverse order (refer to step 11 on page 7 regarding the handling of the seat).

CP250 SERVICE PROCEDURE

1. Open the seat. Remove the felt liner from the front storage compartment. Remove the 7 screws that secure the storage compartments, and then remove the storage compartments.

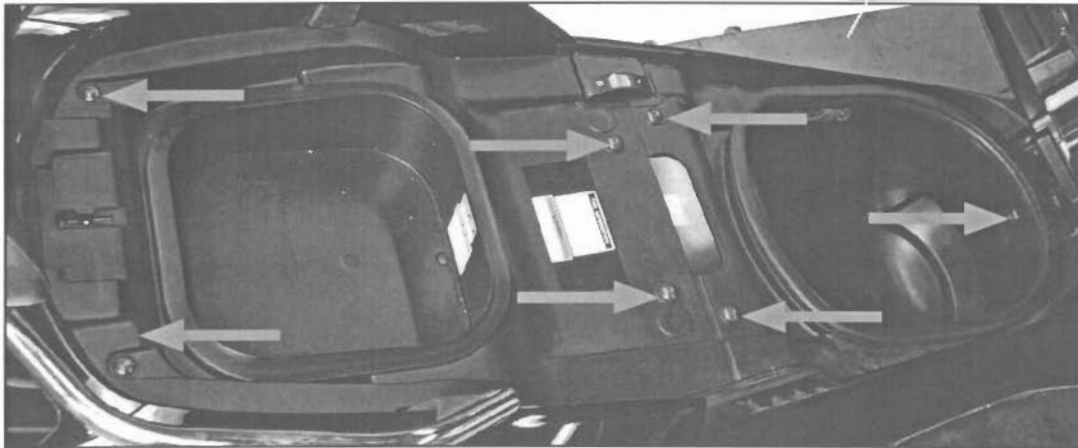

2. Remove the main wire harness coupler from the fuel pump.

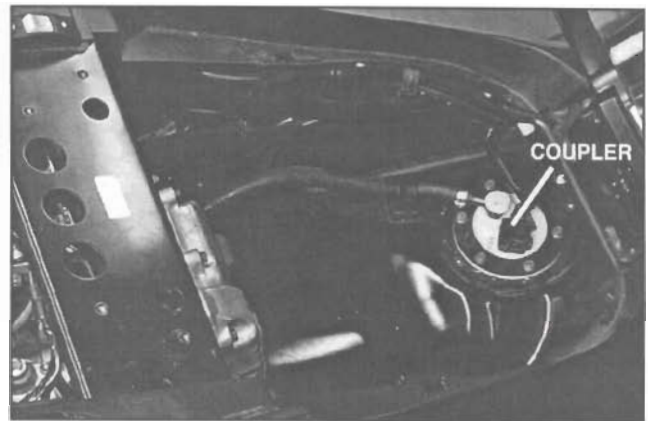

CP250 SERVICE PROCEDURE (CONT'D)

3. Clean the area around the fuel pump thoroughly to prevent any dirt or debris from entering the fuel tank or fuel hose during removal.
4. Inspect the terminals on the harness connector and on the fuel pump. If there is corrosion, replace the main wire harness and/or fuel pump as necessary. Refer to the Service Manual (LIT-11616-19-48) for wire-harness replacement. For tips on replacing the fuel pump, see the procedures given in Technical Bulletin M2007-011R which covers fuel pump seal replacement. If the coupler is wet, but not corroded, dry it with compressed air.

NOTE: If the procedures in Technical Bulletin M2007-011R have not been done, do them now.

5. Using the wide end of the special terminal removal tool, remove the coupler inner cover and rear cap.

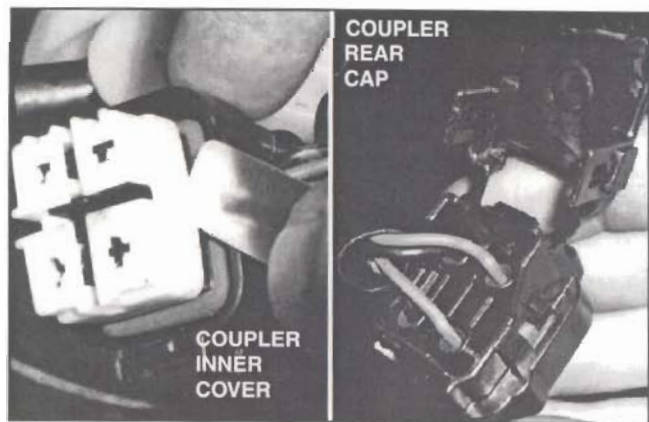
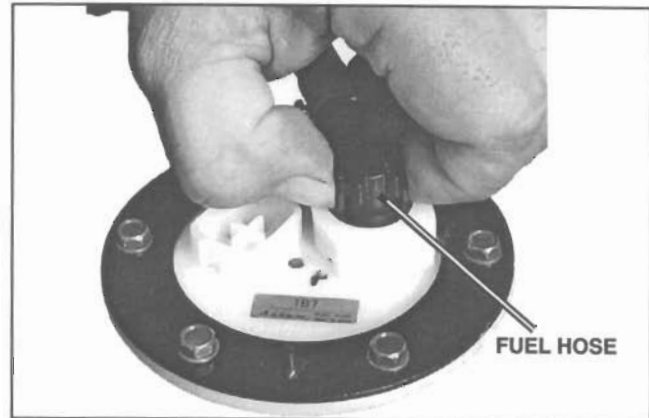
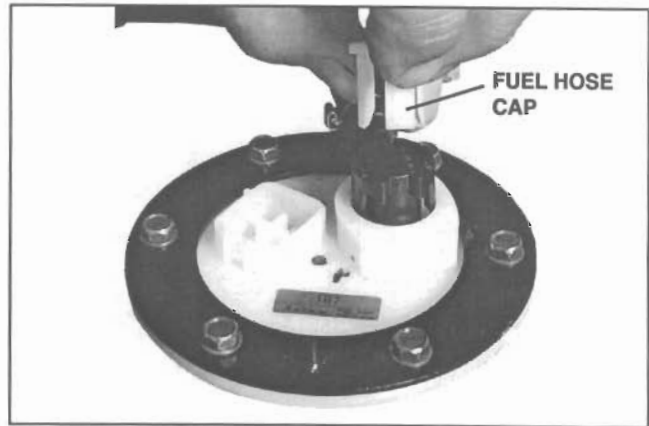

CP250 SERVICE PROCEDURE (CONT'D)

- Using the narrow end of the terminal removal tool, remove the terminals from the fuel pump wire coupler of the main wire harness.
- Remove the coupler inner cover from the new coupler as described in step 5 on the previous page.

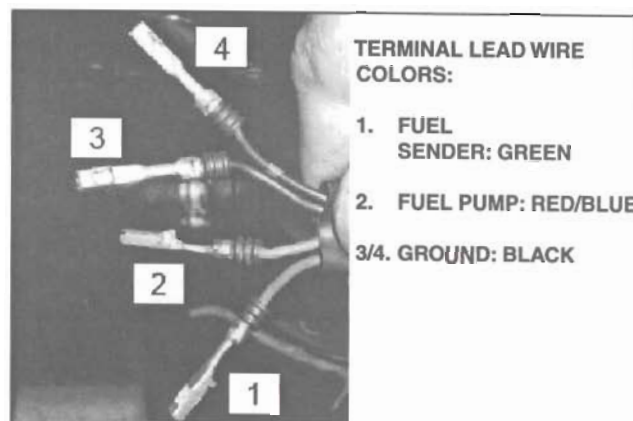
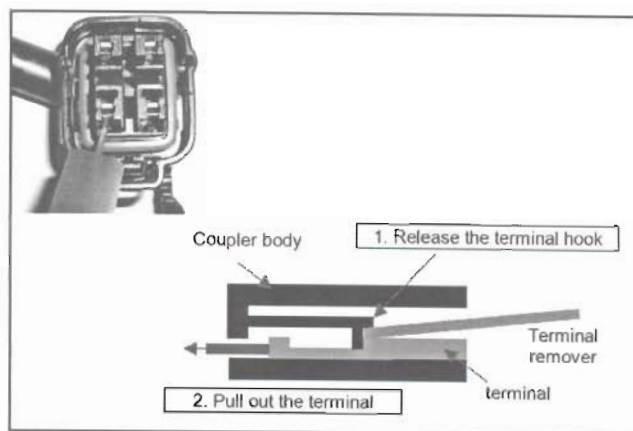

CP250 SERVICE PROCEDURE (CONT'D)

8. Install the wire terminals into the new coupler in the position described below. Make sure to push the terminal into the terminal slot all the way until it clicks. If the terminal is inserted in the wrong direction, it cannot be inserted all the way. Reinstall the inner cover.

NOTE: Either black lead wire terminal can be inserted into either black-labeled slot.

Terminal Lead Wire	Green	Red/Blue	Black	Black
Color of Terminal Slot Label on New Coupler	Green	Red	Black	Black

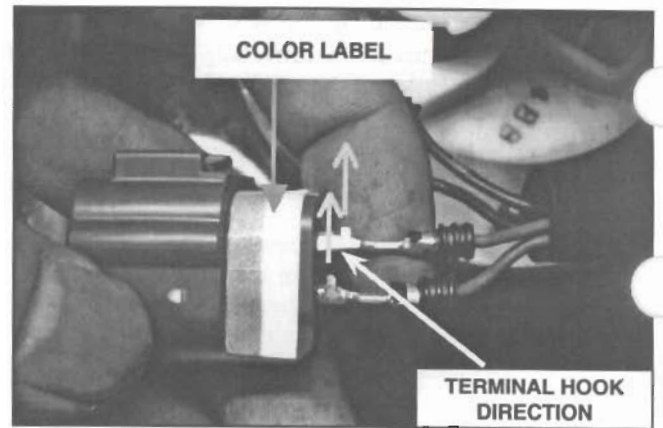

9. Install the fuel pump sub-harness. Plug one end of the fuel pump subharness into the coupler modified in step 8 above and the other into the fuel pump.

CP250 SERVICE PROCEDURE (CONT'D)

10. Secure the fuel pump sub-harness with the supplied plastic bands (zip ties) as shown.

CAUTION:

Be sure to secure the fuel pump sub-harness as shown below. This positions the wire harness coupler of the main wire harness in a position that will allow any water that enters the wire harness to drain.

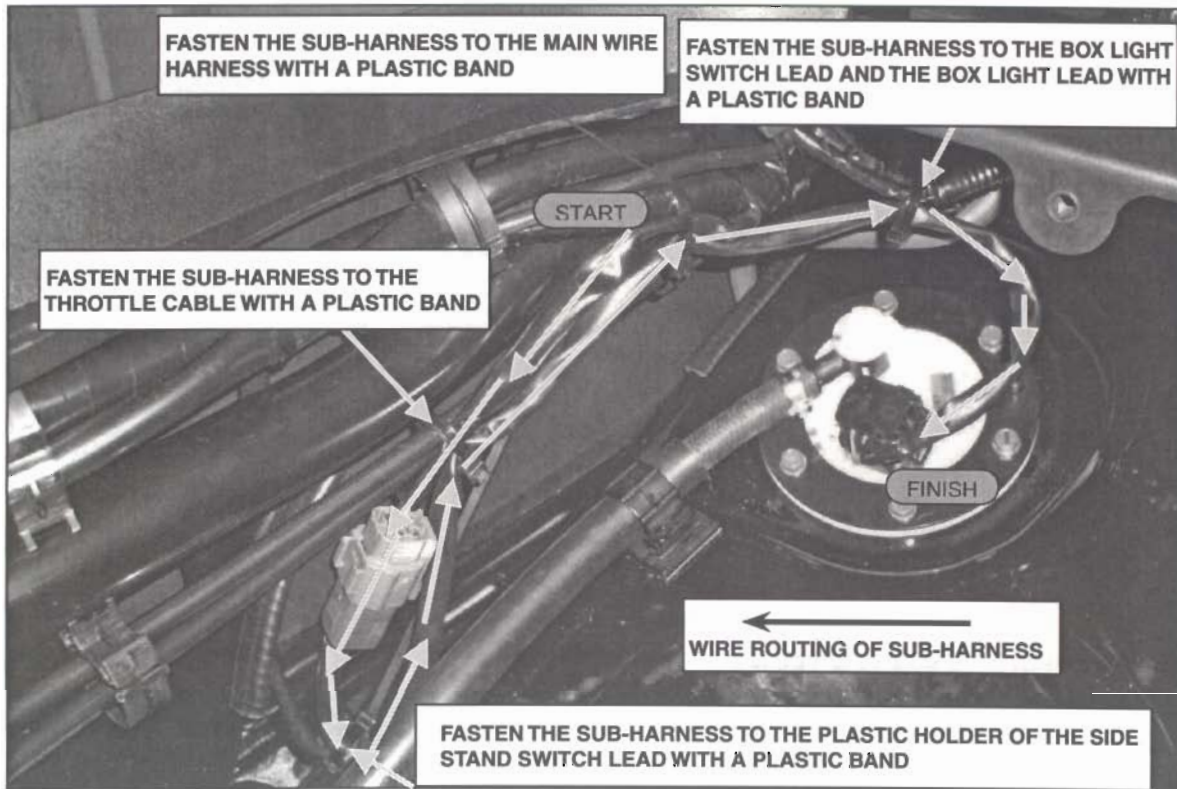

11. After starting the engine to confirm that the fuel pump operates correctly, reassemble the scooter in the reverse order.



PARTS INFORMATION

Model	Part Name	Part Number	Qty	Dealer Cost
YP400	Fuel Pump Sub-harness Kit	90891-30049-00	1	\$9.63
CP250	Fuel Pump Sub-harness Kit	90891-30050-00	1	\$9.63

Kit Part Contents:

No.	Part Name	Qty
1	Sub-harness	1
2	Coupler	1
3	Plastic Band	4

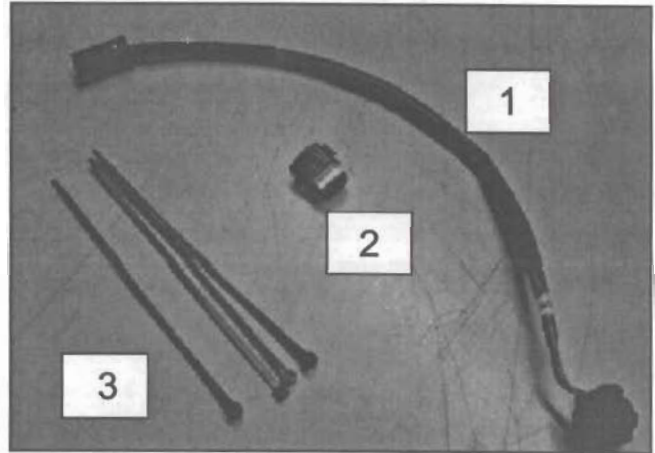

IDENTIFICATION PROCEDURE

When the modification is complete, put a punch mark next to the Primary ID as shown. Check for this punch mark if you encounter an unfamiliar unit. You can also check unit status on YDS or by contacting your Regional Technical Advisor.



NOTE: Because the service procedure is the same, this punch mark is identical to the one made if the procedures in Technical Bulletin M2007-012A were completed prior to this recall announcement. If you already see this mark, the modification was performed previously.



WARRANTY INFORMATION

The owner of each warranty-registered unit will receive a letter announcing this campaign. The letter has a label that includes the Primary ID and Recall Number.

The modification is authorized for all scooters, both sold and unsold, regardless of ownership or warranty status. You do not need the customer's letter to perform the modification or to file for reimbursement.

Submit a Recall Request for the fuel pump sub harness kit as described below using Recall Number **990047**. Choose the status "**M**." You will be reimbursed for the Fuel Pump Sub-harness Kit and your handling fee, plus labor. The labor allowance is **0.3 hour** for CP250 and **1.0 hour** for YP400.

YDS:

When signed on to YDS, click on the Service Tab, and then "Recall Request-Add." This function will allow you to enter multiple Primary IDs for the same recall. Remember that YDS requires a 7-digit serial number, so use a "0" as the first digit. The system will check your submission instantly to make sure the Primary ID numbers you've entered are valid for the recall. You can check back the next day for your claim numbers to track your credit.

MAIL

Complete a recall Reimbursement Request (LIT-11790-00-03) as shown below:

Dealer Number		Dealer Name																												
<input type="text"/>		<input type="text"/>																												
Recall Number		Primary I.D.				Date Completed				Status																				
9	9	0	0	4	7	S	H	0	3	Y	-	0	0	0	4	X	X	X	0	5	-	1	2	-	2	0	0	8	M	I
																													M	I
																													M	I
																													M	I

If the main wire harness and/or fuel pump require replacement because of corrosion that has already occurred, submit a second standard warranty claim for the parts and labor. Reference the claim number of your 990047 Recall Request in the Problem line of this second request. Put only the additional labor necessary for replacing the corroded parts under Extra Labor.

If you have any questions about proper procedures for Factory Modification Campaigns, see Chapter 8 in your Warranty and Y.E.S. Handbook (LIT-11760-00-05).



YAMAHA MOTOR CORPORATION, U.S.A.
6555 KATELLA AVENUE, CYPRESS, CALIFORNIA 90630-5101 800-962-7926

SAFETY RECALL NOTICE

May 6, 2008

Dear Yamaha Owner:

This notice is sent to you in accordance with the requirements of the National Traffic and Motor Vehicle Safety Act. Yamaha Motor Corporation, U.S.A., has determined that a defect which relates to motor vehicle safety exists in all 2006 and certain 2007 CP250 ("Morphous") and all 2005, 2006, and certain 2007 YP400 ("Majesty") scooters. Our records show that you own the affected scooter shown on the label above.

The reason for this recall: In affected scooters, the engine could stall and be difficult to restart because the wire terminals in the fuel pump wire coupler have corroded. This is because water can enter from the main wire harness end and run through the harness to the fuel pump coupler. If the water remains in the coupler for an extended period of time, the terminals can become corroded, which can prevent the fuel pump from operating properly. If this corrosion affects fuel pump operation while the scooter is being ridden, there could be an accident resulting in injury or death.

What Yamaha and your dealer will do: To correct this defect, your authorized Yamaha dealer will install a sub-harness which is designed to allow any water between the wire harness and the fuel pump to drain out before it reaches the fuel pump. Your dealer will also inspect the connectors. If either the main wire harness connector or the fuel pump connector is already corroded, the corresponding assembly(ies) will also be replaced. **There will be no charge to you for this procedure.** Installing the sub-harness takes less than 30 minutes for the Morphous model and about 1 hour for the Majesty model, but your dealer may need to keep your scooter longer depending upon their schedule.

What you should do now: Please call your Yamaha dealer to make a service appointment to have this procedure performed. Remember to take this letter with you when you take in your scooter.

You should not ride your scooter until this modification is performed.

If you are unable to return to the Yamaha dealer who sold you the scooter, this service will be performed by any authorized Yamaha Scooter dealer. For the name of a dealer near you, call 1-800-88-YAMAHA or visit the Yamaha web site at: www.yamaha-motor.com.

Federal regulations require that any vehicle lessor receiving this recall notice must forward a copy of this notice to the lessee within 10 days.

If you need help: If, after contacting your dealership, you have questions or concerns which the dealership is unable to answer, please write to:

Yamaha Motor Corporation, U.S.A.
Customer Relations Department
P.O. Box 6555
Cypress CA 90630
or call 1-800-962-7926

If, after contacting Yamaha Customer Relations, you are still not satisfied that we have done our best to remedy the situation without charge and within a reasonable time, you may submit a written complaint to the Administrator, National Highway Traffic Safety Administration, 1200 New Jersey Avenue, SE., Washington, DC 20590; or call the toll-free Vehicle Safety Hotline at 1-888-327-4236 (TTY: 1-800-424-9153); or go to <http://www.safercar.gov>.

If you no longer own this Yamaha: If you have sold your scooter to another party, please call us toll-free at 1-800-227-5963 with the name and address of the new owner, along with the serial number shown above your name on the address label above.

We're sorry to cause you any inconvenience, but we are sincerely concerned about your safety and continued satisfaction with our products. Thank you for giving your attention to this important matter.

Sincerely,

Customer Support Group
Yamaha Motor Corporation, U.S.A.

Brad Franklin (1)
Government Relations