



Safety Recall: Windshield Wiper Motor Does Not Work

BACKGROUND

A breather port on the windshield wiper motor vents warm air from the wiper motor during operation. If water enters the breather port, it can cause wiper motor corrosion that could make the motor stop working. A non-operating wiper motor increases the risk of a crash in certain conditions.

CUSTOMER NOTIFICATION/CLIENT NOTIFICATION

Owners of affected vehicles will begin receiving a notification of this campaign the week of June 16, 2008. An example of the customer notification is at the end of this service bulletin.

Not all vehicles within the affected VIN range have a wiper motor problem. To verify vehicle eligibility, you **must** check at least one of these items:

- The customer has a notification letter.
- The vehicle is shown as eligible on a VIN status inquiry.

In addition, check for a punch mark above the 13th character of the engine compartment VIN. A punch mark in that location means this campaign has already been completed.

Some vehicles affected by this campaign may be in your used vehicle inventory. You should not sell or lease these vehicles until they have been repaired. Should an unrepaired vehicle cause an injury or damage because of the recalled item, the dealership will be solely responsible to the damaged party, and will be required to defend and indemnify American Honda for any resulting claims. To see if a vehicle is affected by this campaign, do a VIN status inquiry before selling or leasing it.

CORRECTIVE ACTION

Inspect the windshield wiper motor and, depending on its condition, either install a wiper motor kit, or a wiper motor cover kit.

PARTS INFORMATION

Wiper Motor Kit:

P/N: 06760-SDA-A00, H/C 9027137
(Includes a wiper motor and clips for the cowl cover)

Wiper Motor Cover Kit:

P/N 06761-SDA-A00, H/C 9027160
(Includes a cover for the wiper motor and clips for the cowl cover)

WARRANTY CLAIM INFORMATION

OP#	Description	FRT
7401C6	Inspect the wiper motor, and install a wiper motor cover kit.	0.7
7401C7	Inspect the wiper motor, and/or install a wiper motor kit.	0.7

Failed Part: P/N 76505-SDA-A01
H/C 7146368

Defect Code: 5XW00

Symptom Code: Q7800

Skill Level: Repair Technician

REPAIR PROCEDURE

1. Turn the ignition switch to ON (II), and turn on the wipers:
 - If the wipers work, go to step 3.
 - If the wipers don't work, go to step 2.
2. Install a new wiper motor from the wiper motor kit:

NOTE: Torque the windshield wiper arm nuts to **30 N·m (22 lb-ft)**, and replace any damaged cowl cover clips. *To avoid cracking the windshield, do not allow the wiper linkage assembly or any tools to contact the bottom edge of the windshield.*

 - Refer to page 22-253 of the *2003–2007 Accord Service Manual*, or
 - Online, enter keyword **WIPE** and select **Windshield Wiper Motor Replacement** from the list.

Once you replace the wiper motor, go to step 25.

3. Remove the windshield wiper arms:
 NOTE: Do not use a screwdriver to remove the cowl cover. Any tool that contacts the bottom edge of the windshield could cause the windshield to crack.

- Refer to steps 1 and 2 on page 22-253 of the 2003–2007 Accord Service Manual, or
- Online, enter keyword **WIPE**, select **Windshield Wiper Motor Replacement** from the list, and do only steps 1 and 2 of that procedure.

4. Check the part number on the wiper motor:

- If the part number ends with A020, a countermeasured wiper motor is already installed; go to step 24.
- If the part number ends with A011, or if you cannot read the part number, go to step 5.

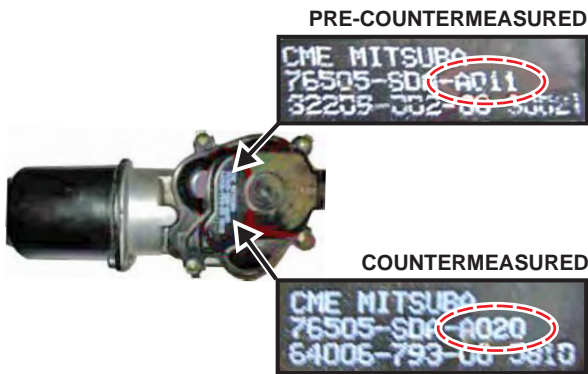

5. Disconnect the wiper motor 5P connector, and detach the wire harness from the wiper linkage.

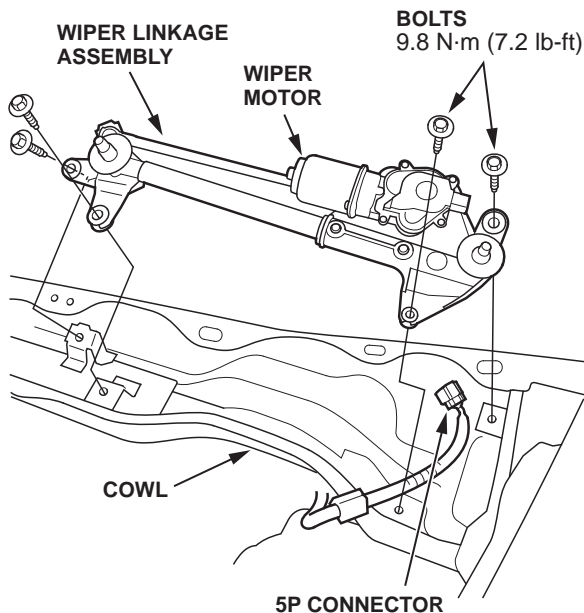

6. Remove the wiper linkage assembly from the cowl (four bolts).

7. Scribe a line across the link and the wiper linkage to mark the original park position of the wipers.

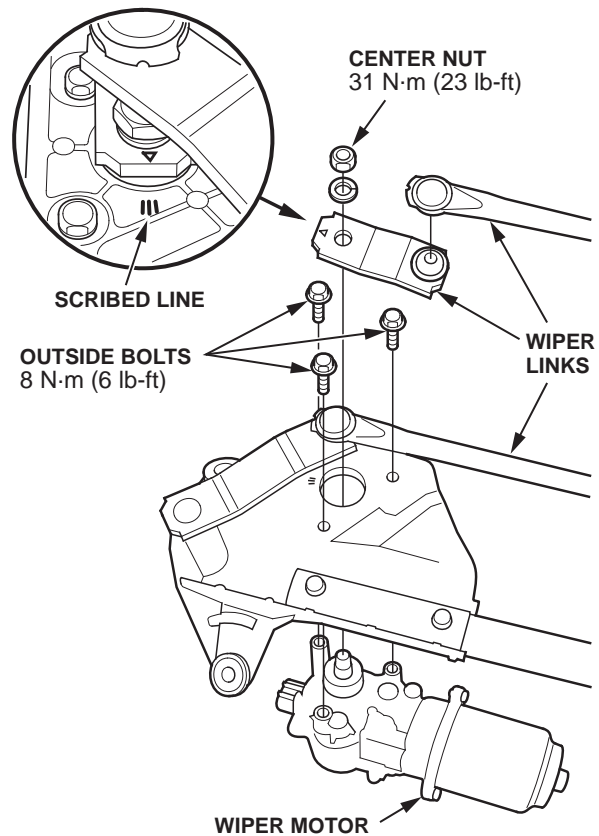

8. Remove the wiper motor from the wiper linkage (one center nut and three outside bolts).

9. Look at the breather port on the wiper motor:

- If the breather port has a splash rib around it, a countermeasured wiper motor is already installed. Go to step 15.
- If there is no splash rib around the breather port, the wiper motor is a pre-countermeasured part. Go to step 10.

COUNTERMEASURED

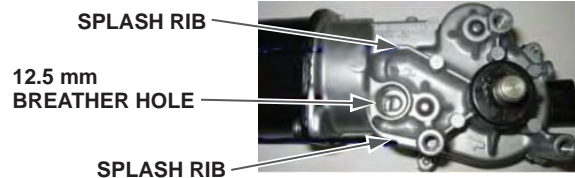

PRE-COUNTERMEASURED

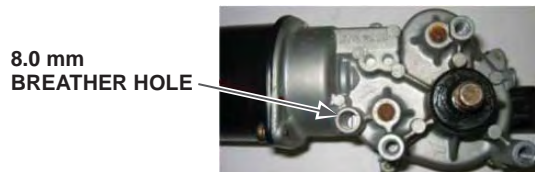

10. Look for rust or cobwebs in the breather port:
- If the breather port is clean, go to step 11.
 - If you see any rust or cobwebs, you'll be installing a wiper motor kit (wiper motor and cowl clips); go to step 15.

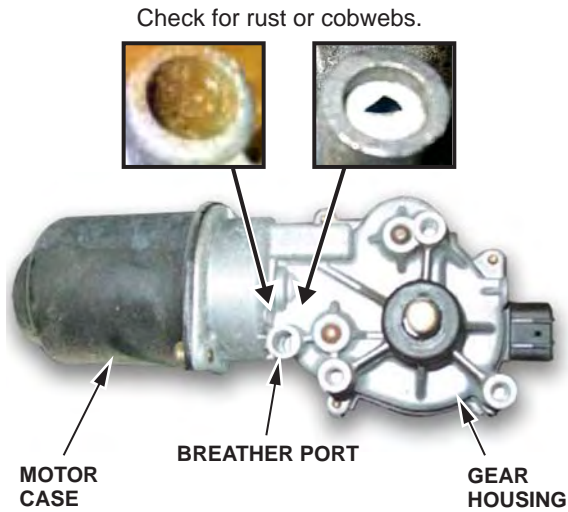

11. Clean the surface of the wiper motor case and the sealing area between the motor case and gear housing with a shop towel.
12. Loosen the two wiper motor screws 3 turns.
- NOTE: Do not remove the motor case from the gear housing (the screws come out after only 5 turns). If you remove the motor case, you could change the position of the magnets inside, causing the motor to run backwards.

WIPER MOTOR SCREWS
(Don't loosen them more than 3 turns.)

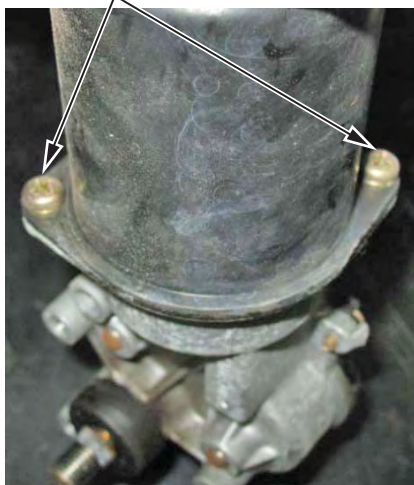

13. With the screws still loose, slightly pull the case away from the housing and look inside:

NOTE:

On VINs beginning with JHM, there's a butyl seal between the motor case and the gear housing. To look inside the case, carefully cut through the butyl all the way around the housing with a utility knife, then slightly separate the two halves.

On VINs beginning with 1HG or 3HG, there's an O-ring between the motor case and the gear housing. To look inside the case, slightly separate the two halves.

- If the inside of the case looks clean, go to step 14.
- If you see any corrosion, mineral deposits, or water inside the case, you'll be installing a wiper motor kit (wiper motor and cowl clips); go to step 15.

INSIDE OF CASE IS CLEAN
(Install cover kit only. Do not install motor kit.)



INSIDE OF CASE IS CORRODED
(Install motor kit only. Do not install cover kit.)



14. On VINs beginning with JHM, retighten the two motor case screws. (You don't need to apply new sealer to the case; the existing butyl will seal the case.) This wiper motor will be reused; go to step 15.

On VINs beginning with 1HG or 3HG, check the condition of the O-ring between the case and the housing:

- If the O-ring is smooth and flat all the way around the housing, the wiper motor will be reused; tighten the two motor case screws, then go to step 15.
- If the O-ring is pinched and/or rolled, you'll be installing a wiper motor kit (wiper motor and cowl clips); go to step 15.

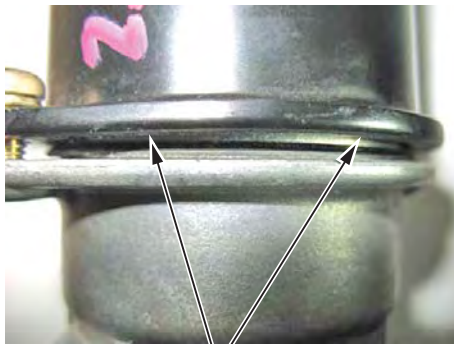

GOOD
O-ring is smooth and flat.

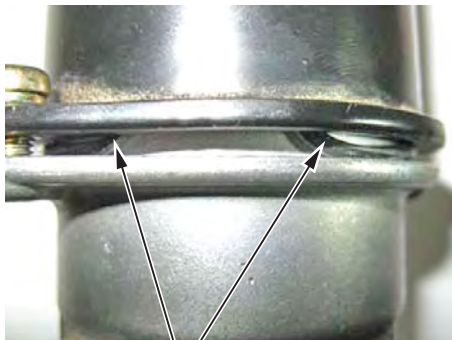

NO GOOD
O-ring is pinched and/or rolled.

15. Place the original or the countermeasured wiper motor in its park position by connecting the 5P connector to the wiper motor and cycling the wiper switch one time.

16. Install the wiper motor onto the wiper linkage using its three outside bolts. Torque the bolts to **8 N·m (6 lb-ft)**.

17. Move the wiper link into the park position you marked in step 7, then tighten the wiper motor center nut just enough to seat its lock washer.

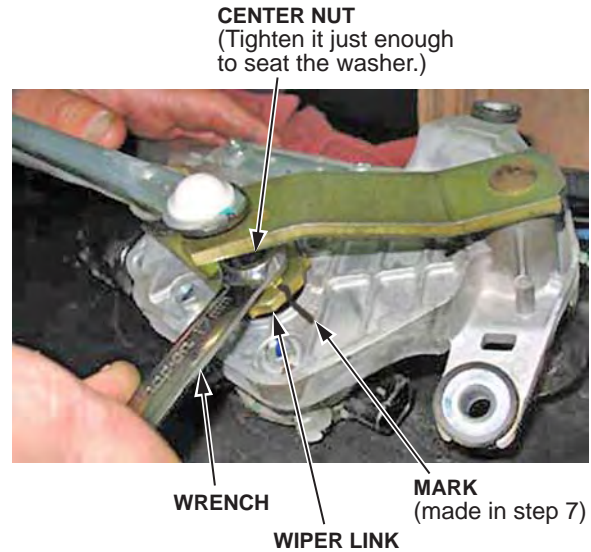

18. Move the linkage until you can fit an adjustable wrench on the wiper arm link, then hold the link with the adjustable wrench while torquing the center nut to **31 N·m (23 lb-ft)**.

- If you're reinstalling a pre-countermeasured wiper motor, go to step 19.
- If you're installing a countermeasured wiper motor, go to step 20.



Hold the link while you tighten the nut.
31 N·m (23 lb-ft)

19. Only if you're reinstalling a pre-countermeasured wiper motor: Install a wiper motor cover:

- Slip the cover over the connector end of the wiper motor.
- Position the cover over the end of the wiper motor case, then snap it into place.
- Make sure the locking tabs on the bottom of the cover are securely fastened.

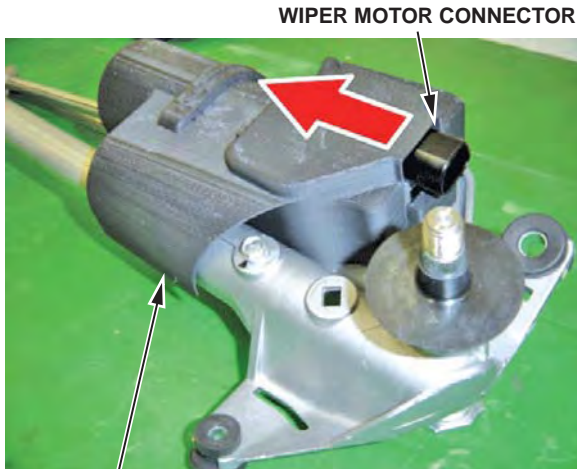

WIPER MOTOR CONNECTOR

WIPER MOTOR COVER

WIPER MOTOR COVER
Press the cover into place.

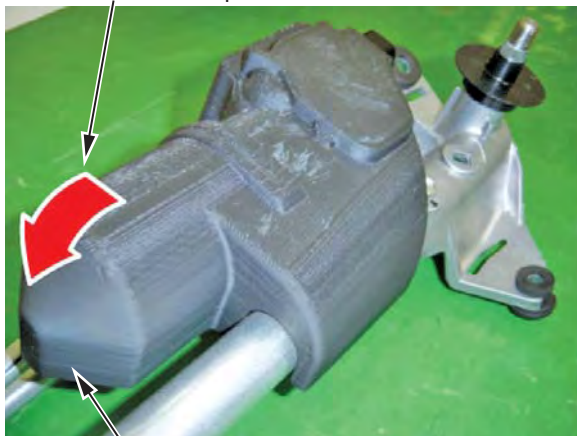

END OF WIPER MOTOR CASE

LOCKING TABS



LOCKING TABS

20. Move the wiper link back to the park position you marked in step 7, then reinstall the wiper linkage assembly on the cowl. Tighten the four wiper linkage assembly bolts to **9.8 N·m (7.2 lb-ft)**.
21. Attach the wire harness to the wiper linkage assembly, then press down firmly on the wiper motor cover as you connect the wiper motor 5P connector.

NOTE: To prevent a soft-set condition, make sure the 5P connector clicks into position.

22. Cycle the wipers one time to get the motor and the linkage into the park position.
23. Lubricate the moving parts of the wiper linkage with multipurpose grease.
24. Reinstall the remaining parts in the reverse order of removal. Note these items:
- Torque the windshield wiper arm nuts to **30 N·m (22 lb-ft)**.
 - Replace any damaged cowl cover clips.
25. Make sure the wiper motor and the wiper arms work correctly.
26. Center-punch a completion mark above the 13th character of the engine compartment VIN.

Center-punch here.

1HGCM5XXXXXXXXXX

Example of Customer Letter

Summer 2008

**Safety Recall: Windshield Wipers
May Stop Working**

Dear Accord Owner:

This notice is sent to you in accordance with the requirements of the National Traffic and Motor Vehicle Safety Act.

What is the reason for this notice?

Honda Motor Co., Ltd., has decided that a defect relating to motor vehicle safety exists in certain 2003 model year Accord vehicles. If water enters the windshield wiper motor housing, corrosion can occur, which may cause the electrical circuit breaker to fail. If the circuit breaker fails, the windshield wiper motor could become inoperative, increasing the risk of a crash in certain conditions.

What should you do?

Call any authorized Honda dealer and make an appointment to have your vehicle repaired. The dealer will inspect the windshield wiper motor and repair or replace it as needed, *free of charge*. Please plan to leave your vehicle for half a day to allow the dealer flexibility in scheduling.

Who to contact if you experience problems.

If you are not satisfied with the service you receive from your Honda dealer, you may write to:

American Honda Motor Co., Inc.
Honda Automobile Customer Service
Mail Stop 500-2N-7A
1919 Torrance Blvd.
Torrance, CA 90501-2746

If you believe that American Honda or the dealer has failed or is unable to remedy the defect in your vehicle, without charge, within a reasonable period of time (60 days from the date you first contact the dealer for a repair appointment), you may submit a complaint to:

Administrator
National Highway Traffic Safety Administration
1200 New Jersey Avenue, S.E.
Washington, DC 20590

You can also call the toll-free Safety Hotline at (888) 327-4236 (TTY [800] 424-9153), or go to <http://www.safercar.gov>.

What to do if you feel this notice is in error.

Our records show that you are the current owner of a 2003 Accord potentially affected by this campaign. If this is not the case, or the name/address information is not correct, please fill out and return the enclosed, postage-paid Information Change Card. We will then update our records.

Lessor information.

Federal law requires that any vehicle lessor receiving this recall notice must forward a copy of this notice to the lessee within 10 days.

If you have questions.

If you have any questions about this notice, or need assistance with locating a Honda dealer, please call Honda Automobile Customer Service at (800) 999-1009.

We apologize for any inconvenience this campaign may cause you.

Sincerely,

**American Honda Motor Co., Inc.
Honda Automobile Division**

June 17, 2008

Dear Service Manager:

Honda Motor Co., Ltd, is announcing a safety recall campaign for 2003 Accord 4-door vehicles. A breather port on the windshield wiper motor vents warm air from the wiper motor during operation. If water enters the breather port, it can cause corrosion that could make the wiper motor stop working. A non-operating wiper motor increases the risk of a crash in certain conditions.

Repair Strategy

Inspect the windshield wiper motor and, depending on its condition, either install a wiper motor kit, or a wiper motor cover kit. For repair and warranty information, refer to Service Bulletin 08-043, *Safety Recall: Windshield Wiper Motor Does Not Work*.

Some vehicles affected by this campaign may be in your used vehicle inventory. You should not sell or lease these vehicles until they have been repaired. Should an unrepaired vehicle cause an injury or damage because of the recalled item, the dealership will be solely responsible to the damaged party, and will be required to defend and indemnify American Honda for any resulting claims.

To see if a vehicle is affected by this campaign, do a VIN status inquiry. In addition, check for a punch mark above the 13th character of the engine compartment VIN. A punch mark in that location means this campaign has already been completed.

Customer Notification

Affected vehicle owners will begin receiving notifications of this campaign the week of June 23, 2008. Customers in the Southeast will be the first to receive notifications. (This particular wiper motor problem is more common in the Southeast.) An example of the customer notification is at the end of S/B 08-043.

Parts Information

Dealers in the Southeast will begin receiving wiper motor kits and wiper motor cover kits before the first customer notifications are sent out. Initially, dealers in other areas of the country will be sent only a few kits. As the campaign is completed in the Southeast, and customer notifications begin mailing in other areas, more kits will be allocated. The ordering method for additional kits will be announced at a later date.

Sincerely,

American Honda Motor Co., Inc.
Honda Automobile Division