



Fleetwood Enterprises, Inc.  
3030 Myers Street / Riverside, CA 92503-5527  
P.O. Box 7638 / Riverside, CA 92513-7638  
p: 800.322.8216 / www.fleetwoodrv.com

## **IMPORTANT RECALL INFORMATION #80311**

May 2008

**TO: ALL FLEETWOOD DEALER PRINCIPALS,  
SERVICE MANAGERS  
AND PARTS MANAGERS**

**SUBJECT: RECALL CAMPAIGN #80311  
2008 & 2009 PULSE AND ICON CLASS C MOTOR HOMES  
ENTRY STEP ATTACHMENT CRADLE/SUPPORT**

Fleetwood Enterprises, Inc., on behalf of its subsidiary manufacturing centers located in Riverside, California and Paxinos, Pennsylvania is requesting your assistance in conducting a voluntary recall notification campaign in accordance with the National Traffic and Motor Vehicle Safety Act.

Fleetwood Enterprises, Inc., has decided that a defect which relates to motor vehicle safety exists in certain 2008 & 2009 model year Pulse and Icon Class C motor homes. We are notifying owners in order to correct the problem. A copy of the letter sent to owners is enclosed for your information.

### ***WHAT IS THE PROBLEM?***

On certain 2008 & 2009 Pulse and Icon Class C motor homes affected by this recall, the entry step attachment cradle/support may bend as a result of step usage and insufficient structural material strength, possibly resulting in risk of personal injury, vehicle and/or other property damage.

### ***WHAT SHOULD YOU DO?***

Owners of the above mentioned motor homes have been asked to contact a Fleetwood dealer to have the described defect remedied. In the event that you are contacted by a customer, please verify eligibility by referring to the serial number range listed in the enclosed Recall Service Bulletin #80311 prior to beginning the repairs.

Once repairs are completed, have the customer sign your dealership's Internal Repair Order and submit your request electronically through e-FDN, or you may also have the customer sign the Fleetwood Repair Order (form X-SR-042) and submit for reimbursement in accordance with Service Bulletin #80311. Customers will not be charged for these repairs.

If you have one of these vehicles in your inventory, you will be mailed a Safety Recall Notice for that specific motor home. Fleetwood is asking our dealers to make repairs to stock units on dealer lots prior to sale or lease.

***Federal Law (Section 154 of the National Highway Traffic and Motor Vehicle Safety Act) of 1966 requires that: If you have received a notice of recall or failure to comply from Fleetwood or any component manufacturer, you must repair or otherwise correct the defects on vehicles remaining in your inventory according to the notification, before selling or leasing the vehicles. Any vehicle lessor receiving this recall notice must forward a copy of the notice to the lessee within ten days.***

Please review this entire package with your parts and service staff to familiarize them with the step-by-step procedure and implement the Voluntary Safety Recall Campaign.

Thank you for helping Fleetwood with its continuing efforts to maintain customer satisfaction. If you have any questions, please contact your regional Fleetwood Service Center.

Sincerely,

FLEETWOOD ENTERPRISES, INC.

A handwritten signature in cursive script that reads "Tina Inkrote".

Tina Inkrote  
Service Administrator  
Motor Home Division

Enclosures: Recall #80311 Customer Letter  
Recall #80311 Service Bulletin

# Recall Bulletin 80311



**RECALL  
BULLETIN:  
80311**

**YEAR(S)  
AFFECTED:  
2008-2009**

**PRODUCT(S)  
AFFECTED:**

Icon, Pulse  
with Serial  
Numbers Listed  
in this Bulletin

**MODEL(S)  
AFFECTED:  
All**

**SUBJECT:**  
Replacement of  
Entry Step Cage

**KEYWORDS:**  
Step, Entry  
Step, Step Cage

**ISSUE DATE:**  
May 2008

The purpose of this Bulletin is to inform all Fleetwood dealers about the need to inspect, and if necessary, replace the step cage for the entry step on Icon and Pulse brand motor homes. A list of affected serial numbers appears at the end of this document.

**CONDITION:**

Insufficient welds on the entry step cage may allow the entry step to break away from its mounting location.

**Read this entire document before proceeding.**

Follow the procedures below for all affected motor homes.

**INSPECTION/CORRECTION:**

Follow the steps below to inspect, and if necessary, remove and replace the entry step supporting cage.

**⚠ SAFETY NOTE**

**In the interest of safety we suggest you remove and maintain control of the ignition key. Attach a "Do Not Use" notice to the ignition switch in order to prevent a third party from powering up the system on which you are working.**

1. Park the motor home on a dry, level, paved surface. Put the transmission into Park and engage the parking brake.
2. Turn off the ignition and remove the ignition key. Maintain control of the ignition key until repairs are completed. This will prevent a third party from activating the ignition or motor home chassis systems.
3. Open the motor home entry door and screen door. Secure the doors in the open position with the entry door holder on the sidewall of the motor home. Turn off the step switch, located on the inside, near the entrance.

© 2008 Fleetwood Enterprises, Inc.

*This bulletin is supplied for technical information only and is not an authorization for repairs.*

Federal Law (Section 151 of the National Traffic and Motor Vehicle Safety Act of 1966) requires that: If you, have received a notice of recall or failure to comply from Fleetwood or any component manufacturer, you must repair or otherwise correct the defects on vehicles remaining in your inventory, according to the notification, before selling or leasing the vehicles. Any vehicle lessor receiving this recall notice must forward a copy of the notice to the lessee within ten days.

\*It is impossible to know, evaluate and advise the service trade of all conceivable ways in which service might be done or of the possible hazardous consequences of each way. Accordingly, anyone who uses a service procedure or tool must first assure that neither personal safety nor vehicle safety will be jeopardized by the selected service methods.

## INSPECTION:

### WARNING

THE ENTRY STEP MAY ACTIVATE AND CYCLE WITHOUT WARNING WHILE CONNECTED TO ELECTRICAL POWER. DO NOT WORK ON AREAS OF THE ENTRY STEP THAT MAY PINCH UNTIL ELECTRICAL POWER HAS BEEN DISCONNECTED.

4. Locate the two horizontal rails of the entry step cage, which provide the bolting location for the entry step. The rails are positioned parallel with the pavement and consist of 1" X 1-1/2" tube steel.
  - A. If the horizontal rails are positioned in a tall configuration, 1-1/2" tall and 1" wide, no further action is necessary and this Bulletin is complete. See Figure 1.
  - B. If the horizontal rails are positioned in a flat configuration, 1" tall and 1-1/2" wide, proceed to the Correction section of this Bulletin. See Figure 2.

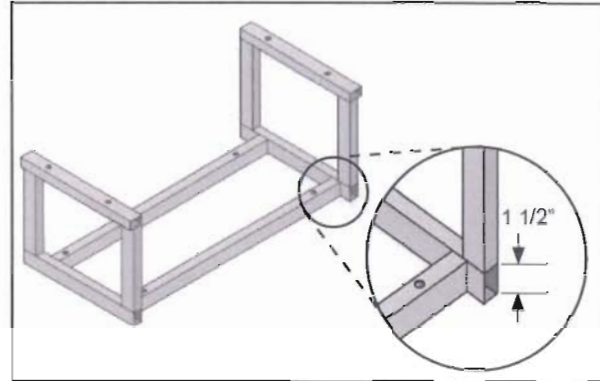

Figure 1

Correct Entry Step Cage - Repair Not Required

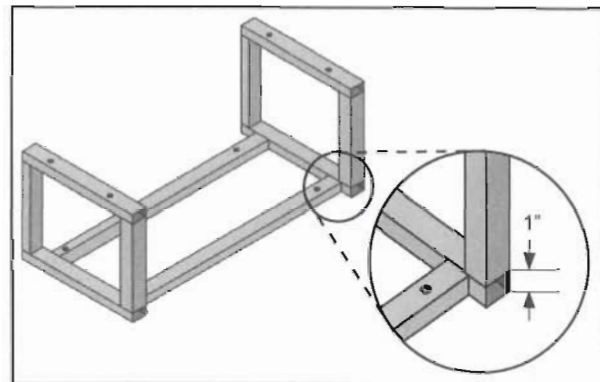

Figure 2

Incorrect Entry Step Cage - Step Cage Replacement Required

## CORRECTION:

5. Unplug the four-way connector for the step controller and unplug the connector for the porch light switch wire. Refer to Figure 3.
6. Disconnect the entry step controller green ground wire from the motor home chassis frame in order to allow removal of the entry step assembly. Retain ground wire fasteners for reassembly.

**NOTE:** Do not cut the green ground wire.
7. Remove the fasteners that attach the entry step assembly to the entry step cage. Note the location of any washers used with the fasteners. Retain washers for reassembly. Discard the bolts and locking nuts. Retain the entry step assembly for reinstallation.

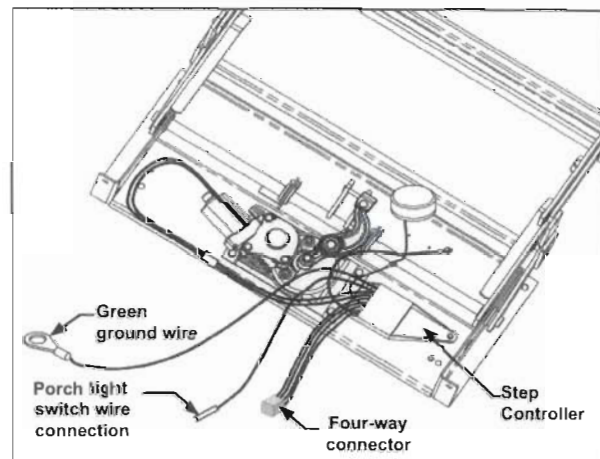

Figure 3

View facing underside of step

*This bulletin is supplied for technical information only and is not an authorization for repairs.*

Federal Law (Section 154 of the National Traffic and Motor Vehicle Safety Act of 1966) requires that: If you have received a notice of recall or failure to comply from Fleetwood or any component manufacturer, you must repair or otherwise correct the defects on vehicles remaining in your inventory, according to the notification, before selling or leasing the vehicles. Any vehicle lessor receiving this recall notice must forward a copy of the notice to the lessee within ten days.

"It is impossible to know, evaluate and advise the service trade of all conceivable ways in which service might be done or of the possible hazardous consequences of each way. Accordingly, anyone who uses a service procedure or tool must first assure that neither personal safety nor vehicle safety will be jeopardized by the selected service methods."

- Remove the locking nuts holding the entry step cage to the underside of the motor home floor and carefully remove the entry step cage. Note the location of any washers used with the fasteners. Retain washers for use with the new entry step cage. Discard the nuts and the entry step cage.

**NOTES:**

- If the magnetic door switch sensor wire prevents removal of the entry step cage, it will need to be labeled and cut. Be sure to allow enough wire length at the cut for reattachment.
- It may be necessary to remove screws from inside the step well battery compartment if the screws protrude through the sheet metal compartment liner and prevent removal of the entry step cage.

- Refer to Figure 4 to determine the correct installation position of the entry step cage:  
Rail "A" is inset 1 1/4" from the outer corner of the entry step cage. Position the step cage assembly so that Rail "A" is nearest the outside sidewall of the motor home. Rail "B", inset 2 3/8" from the opposite corner, upon installation should be nearest the motor home chassis frame rail.

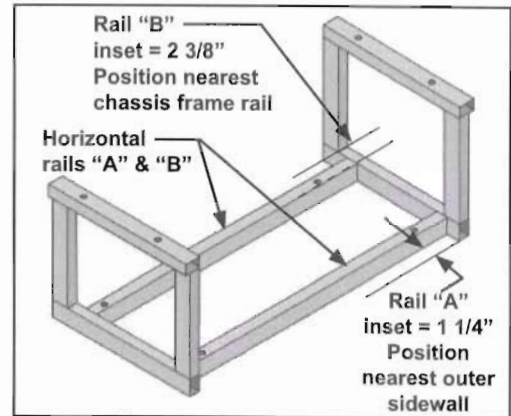

Figure 4

- Position and install the new entry step cage onto the bolts extending through the floor that secured the original component. Install original washers according to the location notes from Step 8, and install new 3/8-16 locking nuts. Torque nuts to 25-30 ft-lbs.
- Align the entry step assembly's mounting holes with the holes in Rails "A" and "B" of the entry step cage. Secure using four new 3/8-16 X 2 1/2 bolts, and four new 3/8-16 locking nuts, along with the original washers in the locations noted in Step 7. Torque nuts to 25-30 ft-lbs.
- Replace any sheet metal fasteners removed in Step 8.
- Clean the entry step controller ground wire attachment location at the chassis frame rail, making sure to remove any corrosion.
- Re-connect the green ground wire, removed in Step 6, to the motor home chassis frame rail using original fastener and star washer.
- Reconnect the four-way connector for the entry step controller and the porch light switch wire connector. If the magnetic door switch sensor wire was disconnected in Step 8, it must also be reconnected using a butt connector and heat shrink tubing.
- Turn on the entry step switch and verify step operation. Correct as necessary.

*This bulletin is supplied for technical information only and is not an authorization for repairs.*

Federal Law (Section 154 of the National Traffic and Motor Vehicle Safety Act of 1966) requires that: If you have received a notice of recall or failure to comply from Fleetwood or any component manufacturer, you must repair or otherwise correct the defects on vehicles remaining in your inventory, according to the notification, before selling or leasing the vehicles. Any vehicle lessor receiving this recall notice must forward a copy of the notice to the lessee within ten days.

"It is impossible to know, evaluate and advise the service trade of all conceivable ways in which service might be done or of the possible hazardous consequences of each way. Accordingly, anyone who uses a service procedure or tool must first assure that neither personal safety nor vehicle safety will be jeopardized by the selected service methods."

**TOOLS:**

- |  |                 |
|--|-----------------|
| Tape Measure                             | Wire Brush      |
| Power Driver with Bits                   | Diagonal Cutter |
| 9/16" Combination Wrench                 | Wire Stripper   |
| 9/16" Deep Socket with Extensions        | Wire Crimper    |
| Air Ratchet or Impact Wrench             | Heat Gun        |
| Torque Wrench - Min. 30 ft-lbs. Capacity |                 |

**PARTS:**

<u>Part Number</u>	<u>Description</u>	<u>Qty.</u>
552018	Kit, Entry Step Cage	1
	Kit Includes:	
	Entry Step Cage	(Qty. 1)
	BOLT- 3/8-16 X 2 1/2 HH PLTD	(Qty. 4)
	NUT- 3/8-16 HH LOCKING PLTD	(Qty. 8)
Obtain Locally	Butt Connectors	As Required
Obtain Locally	Heat Shrink Tubing	As Required

**WARRANTY LABOR ALLOWANCE:**

Use Flat Rate Codes:

Icon/Pulse Entry Step Cradle, includes R/R Step Cage and R/L Entry Step Assembly

9201-11	0.10 hr.	Inspected/Not Defective
9201-12	1.00 hr.	Inspected/Defective/Repaired
9201-17	0.10 hr	Customer Unreachable

*If you have any questions concerning the Bulletin, contact Fleetwood Dealer Technical Support at:  
(800) 816-9825*

Fleetwood Service Literature is available at: [www.fleetwoodrvdealers.com](http://www.fleetwoodrvdealers.com)

*This bulletin is supplied for technical information only and is not an authorization for repairs.*

Federal Law (Section 154 of the National Traffic and Motor Vehicle Safety Act of 1966) requires that: If you have received a notice of recall or failure to comply from Fleetwood or any component manufacturer, you must repair or otherwise correct the defects on vehicles remaining in your inventory, according to the notification, before selling or leasing the vehicles. Any vehicle lessor receiving this recall notice must forward a copy of the notice to the lessee within ten days.

"It is impossible to know, evaluate and advise the service trade of all conceivable ways in which service might be done or of the possible hazardous consequences of each way. Accordingly, anyone who uses a service procedure as tool must first assure that neither personal safety nor vehicle safety will be jeopardized by the selected service methods."

## Recall Bulletin 80311 Affected Motor Home Serial Numbers

### 2008 Pulse

765A84798718
765D84798976
765A84799285
765A84799323
765A84799324
765A84799325
765A84799326
765D84799393
765D84799394
765A84799415
765A84799416

765A84799485
765A84799486
765A84799487
765A84799488
765D84799498
765D84799499
765D84799500
765D84799501
765D84799502
765D84799503
765D84799504

765D84799505
765D87172452
765A87172673
765A87172763
765A87172764
765A87172858
765D87172894
765A87172956
765A87172957
765A87172958
765D87172961

765D87172962
765D87172963
765D87172964
765D87173031
765D87173032
765A87173047
765A87173048
765A87173049

### 2009 Pulse

765A97173144
765A97173145

765A97173146
765A97173148

765A97173149
765A97173151

765A97173152
--------------

### 2008 Icon

766A84798719
766D84798977
766A84799286
766D84799391
766D84799392
766A84799413
766A84799414

766A84799489
766A84799490
766A84799491
766A84799492
766A84799493
766A84799494
766D84799495

766D84799496
766D84799497
766D87172769
766A87172859
766A87172860
766D87172895
766D87172918

766D87172919
766D87172920
766A87172959
766A87172960
766D87172965
766D87173030
766A87173046

### 2009 Icon

766A97173142
--------------

766A97173143
--------------

766A97173154
--------------

766A97173155
--------------

*This bulletin is supplied for technical information only and is not an authorization for repairs.*

Federal Law (Section 154 of the National Traffic and Motor Vehicle Safety Act of 1966) requires that: If you have received a notice of recall or failure to comply from Fleetwood or any component manufacturer, you must repair or otherwise correct the defects on vehicles remaining in your inventory, according to the notification, before selling or leasing the vehicles. Any vehicle lessor receiving this recall notice must forward a copy of the notice to the lessee within ten days.

"It is impossible to know, evaluate and advise the service trade of all conceivable ways in which service might be done or of the possible hazardous consequences of each way. Accordingly, anyone who uses a service procedure or tool must first assure that neither personal safety nor vehicle safety will be jeopardized by the selected service methods."



Fleetwood Enterprises, Inc.  
3030 Myers Street / Riverside, CA 92503-5527  
P.O. Box 7638 / Riverside, CA 92513-7638  
p: 800.322.8216 / www.fleetwoodrv.com

## **IMPORTANT RECALL INFORMATION #80311**

May 2008

Dear Valued Fleetwood Motor Home Customer:

This notice is sent to you in accordance with the requirements of the National Traffic and Motor Vehicle Safety Act.

Fleetwood Enterprises, Inc., on behalf of its subsidiary manufacturing centers located in Riverside, California and Paxinos, Pennsylvania has decided that a defect which relates to motor vehicle safety exists in certain 2008 & 2009 model year Pulse and Icon Class C motor homes.

### ***WHAT IS THE PROBLEM?***

On certain 2008 & 2009 Pulse and Icon Class C motor homes affected by this recall, the entry step attachment cradle/support may bend as a result of step usage and insufficient structural material strength, possibly resulting in risk of personal injury, vehicle and/or other property damage.

### ***WHAT SHOULD YOU DO?***

Please make certain your motor home is inspected and repaired by contacting your selling dealer, and making an appointment to have this inspection and repair performed. If they are not available, another Fleetwood motor home dealer may do this work for you.

### ***WHAT WILL FLEETWOOD DO?***

With your continued satisfaction in mind, it is our intention to have these repairs made at your convenience with as little disruption as possible. Effective immediately, Fleetwood dealers will be supplied with all the information needed to enable them to inspect and if necessary, reinforce the entry step attachment cradle/support.

The total length of time your motor home will be out of service will depend on the dealer's work schedule.

If you have had this concern corrected previously, you may be eligible for reimbursement of your cost for that repair. For more information regarding this recall #80311, contact Fleetwood Owner Relations at 800-509-3418.

When you deliver your motor home for repairs, your dealer will complete a Fleetwood Repair Order. Upon completion of the repair, please sign the dealership's Repair Order or Fleetwood's Repair Order and fill out the enclosed self-addressed Vehicle Information Update Card and return it to Fleetwood. This will allow us to update our records and if necessary, notify the new owner using the information you provided.

***For leased vehicles: Federal regulation requires that any vehicle lessor receiving this recall notice must forward a copy of this notice to the lessee within ten days.***

If you are unable to obtain the specified repair promptly and without charge, please contact:

**FLEETWOOD OWNER RELATIONS - RECALL #80311**

P.O. Box 1007  
Decatur, Indiana 46733  
(800) 509-3418

If you believe that the dealer and Fleetwood Enterprises, Inc., have failed or have been unable to remedy the defect without charge or within a reasonable period of time, you may submit a complaint to:

Administrator  
National Highway Traffic Safety Administration  
1200 New Jersey Avenue, SE  
Washington, DC 20590

Or call the toll-free Vehicle Safety Hotline at 1-888-327-4236 (TTY: 1-800-424-9153); or go to  
<http://www.safercar.gov>

Fleetwood Enterprises, Inc., is taking these steps in the interest of your safety. We regret any inconvenience this may cause you.

Sincerely,

FLEETWOOD ENTERPRISES, INC.



Tina Inkrote  
Service Administrator  
Motor Home Division