

GM SERVICE AND PARTS OPERATIONS

DCS2181

URGENT - DISTRIBUTE IMMEDIATELY

Date: November 11, 2008

Subject: 15204 – Noncompliance Recall
A-Pillar Trim Replacement

Models: 2006-2008 Saab 9-5
VIN Range: 63500026 - 83512093

To: All Saab Dealers

Attention: Service Manager, Parts Manager, and
Warranty Administrator

PRODUCT FIELD ACTION ANNOUNCEMENT

Saab Automobile AB has announced a noncompliance recall that involves replacing the A-pillar trim on 2006-2008 Saab 9-5 vehicles within the following VIN range: 63500026 – 83512093.

These vehicles may fail to conform to Federal Motor Vehicle Safety Standard 201, "Occupant Protection in Interior Impact". In a test at an impact point at the A-pillar trim, the Standard's requirement was exceeded.

An initial supply of parts will be automatically shipped to dealers. Additional parts must be ordered through normal parts order process.

For any vehicle within the VIN range stated above, first check the "Warranty Inquiry By Chassis" screen on IRIS to determine whether the recall has been completed.

Notification letters will be mailed to owners of affected vehicles beginning on or about November 25, 2008.

Important! Any affected vehicles in dealer inventory MUST NOT be delivered or put into service prior to completion of this non compliance recall.

Warranty Claim Information:

Installation of new A-pillar trims

Object Code	15204
Fault/Reason Code	71
Location Code	0
Warranty Type	05
Repair/Action Code	01
Recall Action Code (RAC)	3
Labor Operation	1520401
Labor Time	0.3

The labor time includes 0.1 to cover administrative costs.

If you have any questions concerning this recall, please contact the Technical Assistance Center at 1-877-446-8227.

**CLICK ON THE MESSAGE ATTACHMENTS
BELOW TO VIEW OR PRINT THE MODIFICATION
INSTRUCTION DOCUMENT AND/OR THE OWNER LETTER**

END OF MESSAGE

GM SERVICE AND PARTS OPERATIONS



MODIFICATION INSTRUCTION

MI No. 855-2712	Date November 2008	9-5
Distr. US		

Replacing the A-pillar trim

Non Compliance Recall 152 04

Cars in stock must be rectified before delivery.

A personal communication must be sent to the owners of cars already delivered requesting them to get in touch with the nearest Saab garage as soon as possible to have the fault rectified.

Cars affected

Saab 9-5 M06-08 within Vehicle Identification Number range 63500026-83512093.

Background

The A-pillar trim does not fulfil the FMVSS 201U legal requirement with regard to head protection.

Parts required

12842653 A-pillar trim (left)

12842654 A-pillar trim (right)

Procedure

To remove

- 1 Remove the door weatherstrip from the A-pillar.
- 2 Pull the A-pillar trim loose (fastened with clips).
- 3 Remove the top clip from the A-pillar using diagonal cutting pliers.
- 4 Lift away the trim.

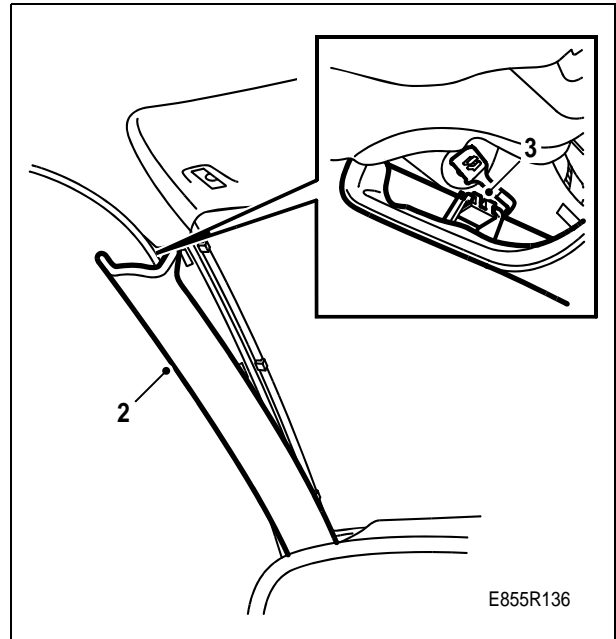

- 5 Remove the parking ticket holder, if fitted.

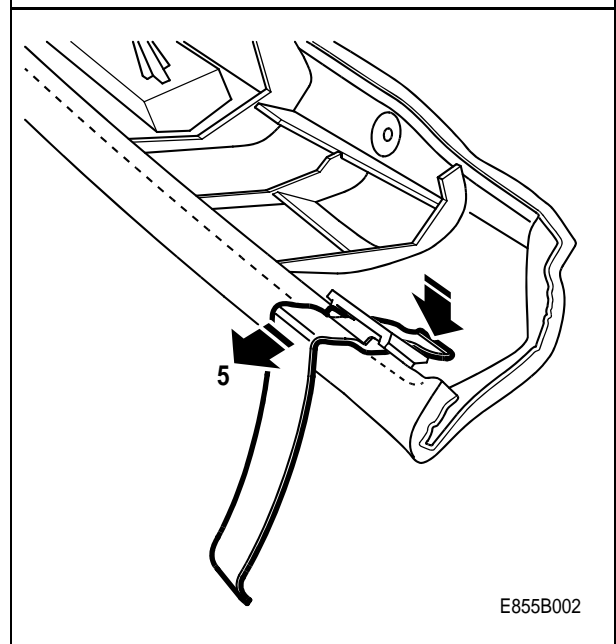

To fit**⚠ WARNING**

Take care to avoid damaging or loosening the energy absorbers. A damaged or loosened energy absorber must not be refitted. Replace the A-pillar trim where appropriate. A damaged energy absorber could provide reduced protection to the head in the event of impact.

- 1 Refit the parking ticket holder, if one was fitted, and fit the new trim.

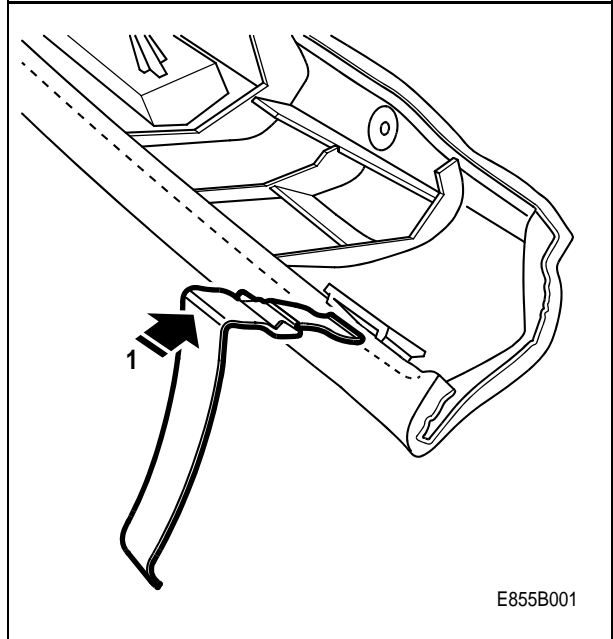
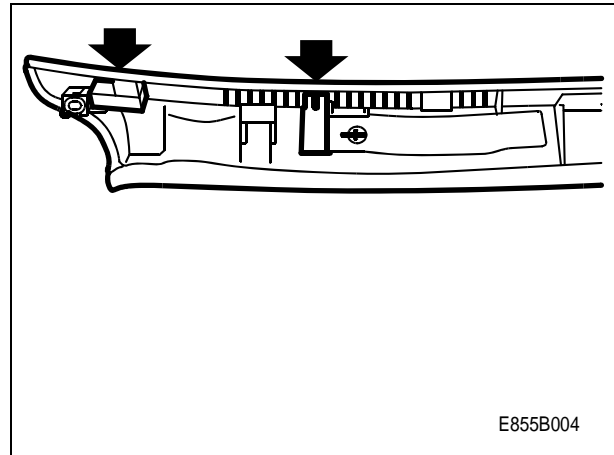

- 2 Fit the lower section of the new trim in place.
- 3 Press in the new trim at all 3 clips.
- 4 Fit the door weatherstrip.

Note

- The A-pillar trim must be replaced on both sides.
- Replaced A-pillar trims must be discarded.

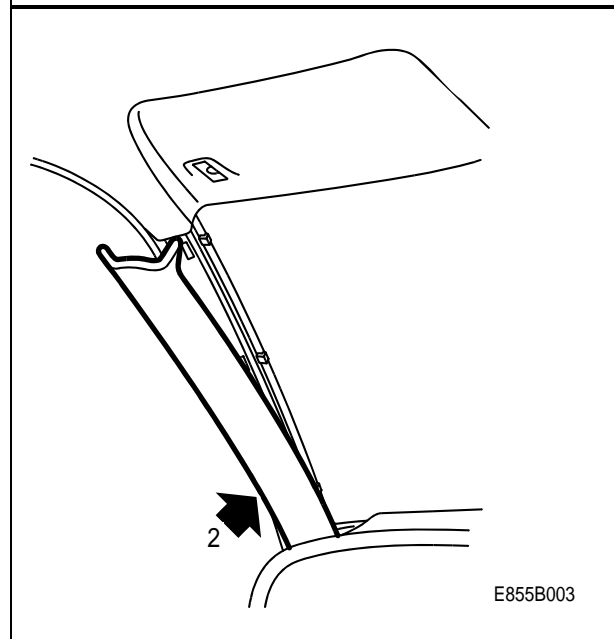
**Warranty/Time Information**

See separate information.