



# Service Bulletin No. 289

MODEL G Series Coaches	TYPE Field Change Program	SECTION/GROUP 2--Tag Axle	DATE Mar. 18, 2008
SUBJECT TAG AXLE RETROFIT			
CONDITIONS			

Ref. NHTSA Recall No.: 08V--121

Ref. Transport Canada Recall No.: 08--093

### Customer Complaint:

Some customers have reported cracking originating at the heat-affected zone of the weld on tag axle arm assemblies reworked during MCI Campaign 212, released in December 2003 ( Ref. NHTSA Recall No.: 03V-411, Ref. TC Recall No.: 03-251 ).

### Cause:

Incorrect identification / inspection of the tag axle arm assemblies for identifiable cracks or incorrect welds in the previously repaired areas.

### Corrective Action:

MCI will make arrangements for a re-inspection of all G model tag axle arms for identifiable cracks or incorrect welds in the previously repaired areas. If any related issue is identified, both right and left tag axle arm assemblies will be replaced with newly designed assemblies.

As a result, MCI advises that owners of G4500 model coaches between the range of, and including, unit numbers 80001 to 80518 and 62536 to 62561 implement the specified steps in this procedure by contacting MCI to make an appointment to have this inspection completed.



## NOTE

**REFER TO PAGE 2 OF THIS BULLETIN FOR REQUIRED PARTS LIST.**

**G4500 MODEL COACHES BETWEEN THE RANGE OF, AND INCLUDING, 80026-80035, 80046-80055, 80071-80171, 80182-80190, 80195-80214, 80237-80253, 80266-80288, 80310-80359, 80388-80500, 62536-62561 ARE EQUIPPED WITH DANA AXLES.**

**G4500 MODEL COACHES BETWEEN THE RANGE OF, AND INCLUDING, 80036-80045, 80056-80070, 80172-80181, 80191-80194, 80215-80236, 80254-80265, 80289-80309, 80360-80387, 80501-80518 ARE EQUIPPED WITH ARVINMERITOR AXLES.**

### **Service Procedure:**

#### **General notes**

Read this entire procedure before beginning work.

Use Safe Shop Practices At All Times.



## REFER TO MANUAL

**Refer to Section 2B / Trailing Axle, in the MCI G Series Maintenance Manual, in conjunction with this procedure.**

# Service Bulletin No. 289

DATE MAR. 18, 2008 PAGE 2

## Parts Required If Cracks Are NOT Present Upon Inspection

Qty.	New P/N	Description
a/r	26-02-0001	Kit - Hardware, Tag Axle, Field Retrofit ( as per inspection )
		<i>Kit Contents Are:</i>
2	02-06-6036	Bearing – Tapered, Outer
2	2L-6-349	Seal, Oil
2	02-06-1069	Washer
2	02-06-1070	Nut, Lock
2	02-06-6079	O–ring
a/r	21-7512-2	Gear Lube

## Parts Required If Cracks Are Present Upon Inspection

Qty.	DANA AXLE	ARVINMERITOR AXLE	Description
a/r	02-06-1071	02-06-1077	Kit - Tag Axle, LH, Retrofit ( as per inspection )
			<i>Kit Contents Are:</i>
1	02-06-1056	02-06-1056	Tag Axle Arm Assy, LH
1	02-06-1052	02-06-1052	Bearing – Tapered, Outer
1	02-06-1069	02-06-1069	Washer
1	02-06-1070	02-06-1070	Nut, Lock
1	02-06-6037	02-06-6037	Bearing – Tapered, Inner
1	02-06-6079	02-06-6079	O–ring
8	15-05-1006	15-05-1006	Capscrew
1	15-05-6036	15-05-6036	Gasket, Hub Cap
1	15-05-6038	15L-5-167	Hub Seal, Oil
8	15-05-6051	15-05-6051	Nut, Lock
8	15-05-6052	15-05-6052	Washer, Flat
4	19-01-6228	19-01-6228	Capscrew, M24–2 x 50
4	19-02-6076	19-02-6076	Washer, M24–25 ID, 44OD
1	2L-6-349	2L-6-349	Seal, Oil
a/r	21-7512-2	21-7512-2	Gear Lube
a/r	23-01-0029	23-01-0029	Gear Oil

AND

Qty.	DANA AXLE	ARVINMERITOR AXLE	Description
a/r	02-06-1054	02-06-1078	Kit - Tag Axle, RH, Field Retrofit ( as per inspection )
			<i>Kit Contents Are:</i>
1	02-06-1034	02-06-1034	Tag Axle Arm Assy, RH
1	02-06-1052	02-06-1052	Bearing – Tapered, Outer
1	02-06-1069	02-06-1069	Washer
1	02-06-1070	02-06-1070	Nut, Lock
1	02-06-6037	02-06-6037	Bearing – Tapered, Inner
1	02-06-6079	02-06-6079	O–ring
8	15-05-1006	15-05-1006	Capscrew
1	15-05-6036	15-05-6036	Gasket, Hub Cap
1	15-05-6038	15L-5-167	Hub Seal, Oil
8	15-05-6051	15-05-6051	Nut, Lock
8	15-05-6052	15-05-6052	Washer, Flat
4	19-01-6228	19-01-6228	Capscrew, M24–2 x 50
4	19-02-6076	19-02-6076	Washer, M24–25 ID, 44OD
1	2L-6-349	2L-6-349	Seal, Oil
a/r	21-7512-2	21-7512-2	Gear Lube
a/r	23-01-0029	23-01-0029	Gear Oil

1. Turn the main battery disconnect switch to the OFF position.



## NOTE

*Raise the coach to the desired height. Position jackstands at the front and rear frame support points, according to Figure 1, to ensure that the coach is securely supported before attempting work underneath the coach.*

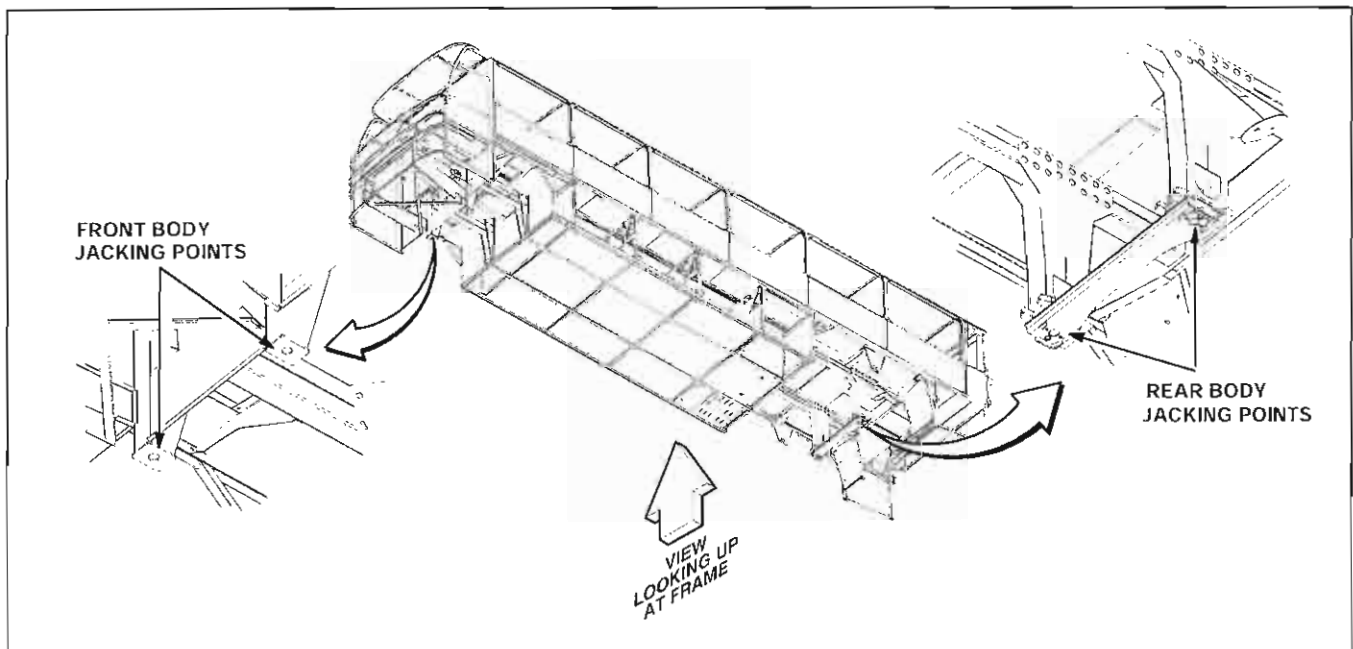

Figure 1. Underframe Jackstand Support Points ( Section 3H / Maintenance Manual )



## REFER TO MANUAL

*Refer to Section 3H / Towing and Jacking, in the MCI G Series Maintenance Manual, for the basic rules, procedures and safety precautions that must be followed before a coach is to be lifted.*



## NOTE

*The tag axle should be lifted only when the tag axle's suspension air bellows are exhausted. Close the tag axle suspension shut-off valves, located in the RH, rear service compartment ( Figure 2 ).*

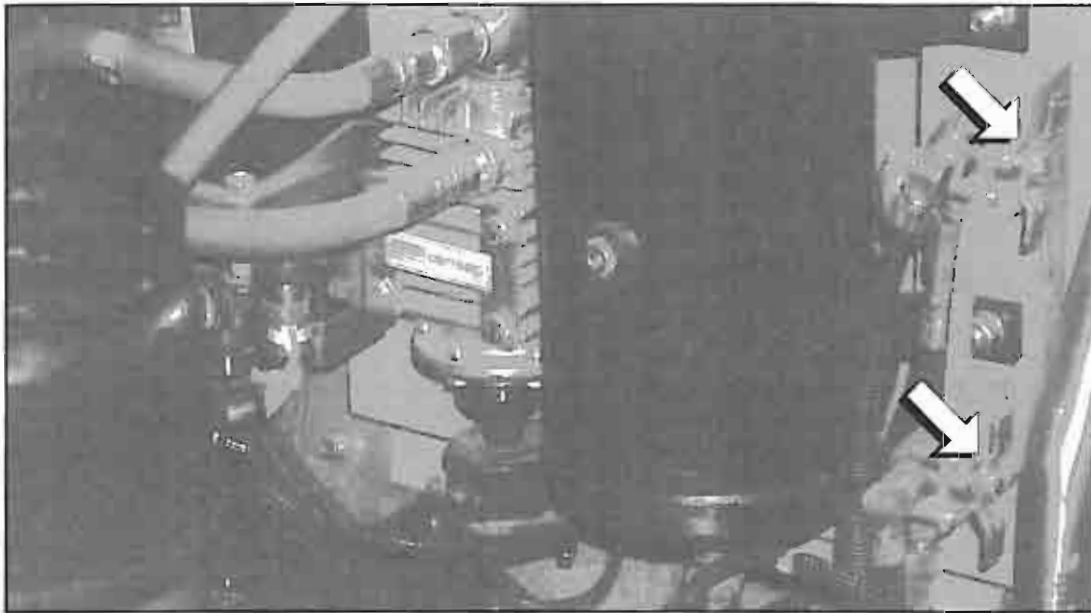

Figure 2.

2. Support the drive and tag axes.
3. Remove the drive and tag axle wheels.



## REFER TO MANUAL

*Refer to the Maintenance Manual / Section 15 / Wheels, Hubs and Tires, for the basic procedures on wheel removal and installation.*

*Use caution during wheel removal as wheel and tire assemblies weigh in excess of 100 pounds.*

4. Disconnect the air lines from tag axle suspension air spring bellows and brake chamber air fittings.
5. Using a twisting motion, remove the ABS sensor, located in the inner top of LH / RH brake spider mounting flanges, with bushing from the axle housing's flange.
6. Unfasten the suspension air spring bellows from the chassis mounting pads.

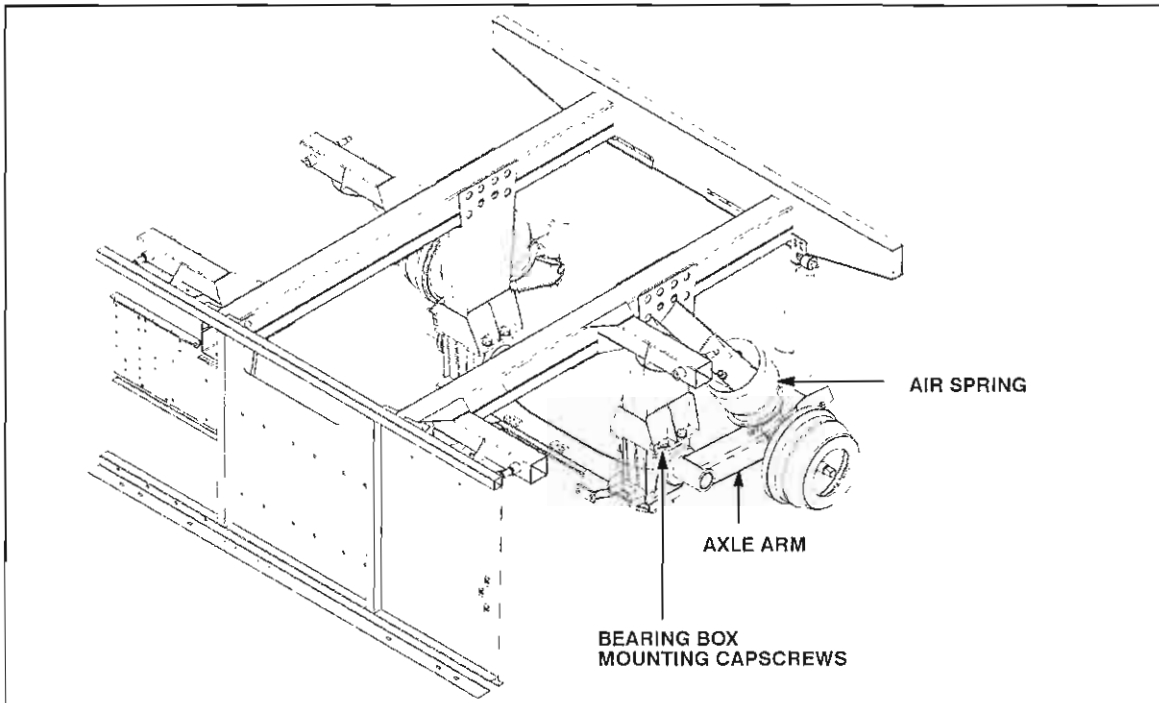

Figure 3.

7. Using solvent and a wire brush as necessary, carefully clean the welded joints on both tag axle assemblies. Visually inspect the LH and RH tag axle arm assemblies for cracks, paying particular attention to the welded areas.



***DO NOT PROCEED PRIOR TO READING***

**IF NO CRACKS ARE PRESENT ON EITHER THE LH AND RH TAG AXLE ARM ASSEMBLIES INSTALL RETROFIT KIT P/N 26-02-0001, FOLLOWING THE OUTLINED STEPS 8. to 23.**

**IF CRACKS ARE PRESENT UPON TAG AXLE ARM INSPECTION ON EITHER OR BOTH THE LH AND RH TAG AXLE ARM ASSEMBLIES, NEW TAG AXLE ARMS WILL NEED TO BE INSTALLED ON BOTH SIDES OF THE THE COACH. PROCEED TO STEP 24.**

**Steps 8 to 23 cover the installation of retrofit kit p/n 26-02-0001 for coaches where NO CRACKS are found upon inspection**

8. Remove the shock absorber from the tag axle arm pin. Retain the bushings, washers and nut to be re-installed at a later step in this procedure.
9. Remove the drain plug from the bearing box. Dispose of oil in an appropriate manner. Remove and retain the retaining ring and closing plate from the bearing box assembly ( Figure 4 ). Remove and discard the o-ring from the bearing box. Remove and discard the shaft nut and washer from the end of the tag axle arm trunnion shaft.
10. Remove the cone of the inner bearing ( p/n 02-06-6037 ). Take care to protect the bearing from contamination and place aside to be re-installed at a later step in this procedure. Inspect the bearing, ensuring that it is in good condition. Remove the tag axle arm from the bearing box, being carefull not to damage the cup ( outer race ) of the inner bearing or the threads and the end of the trunnion shaft. Remove and discard the outer bearing ( p/n 02-06-6036 ) and seal ( p/n 2L-6-349 ), using a long punch through the bearing box to carefully remove the outer race.
11. Re-assemble the bearing box and tag axle arm using a new outer bearing ( p/n 02-06-6036 ), oil seal ( p/n 2L-6-349 ) and re-using the existing inner bearing ( p/n 02-06-6037 ) removed in Step 10. ( Figure 4 ). Install the new washer ( p/n 02-06-1069 ) and lock nut ( p/n 02-06-1070 ).

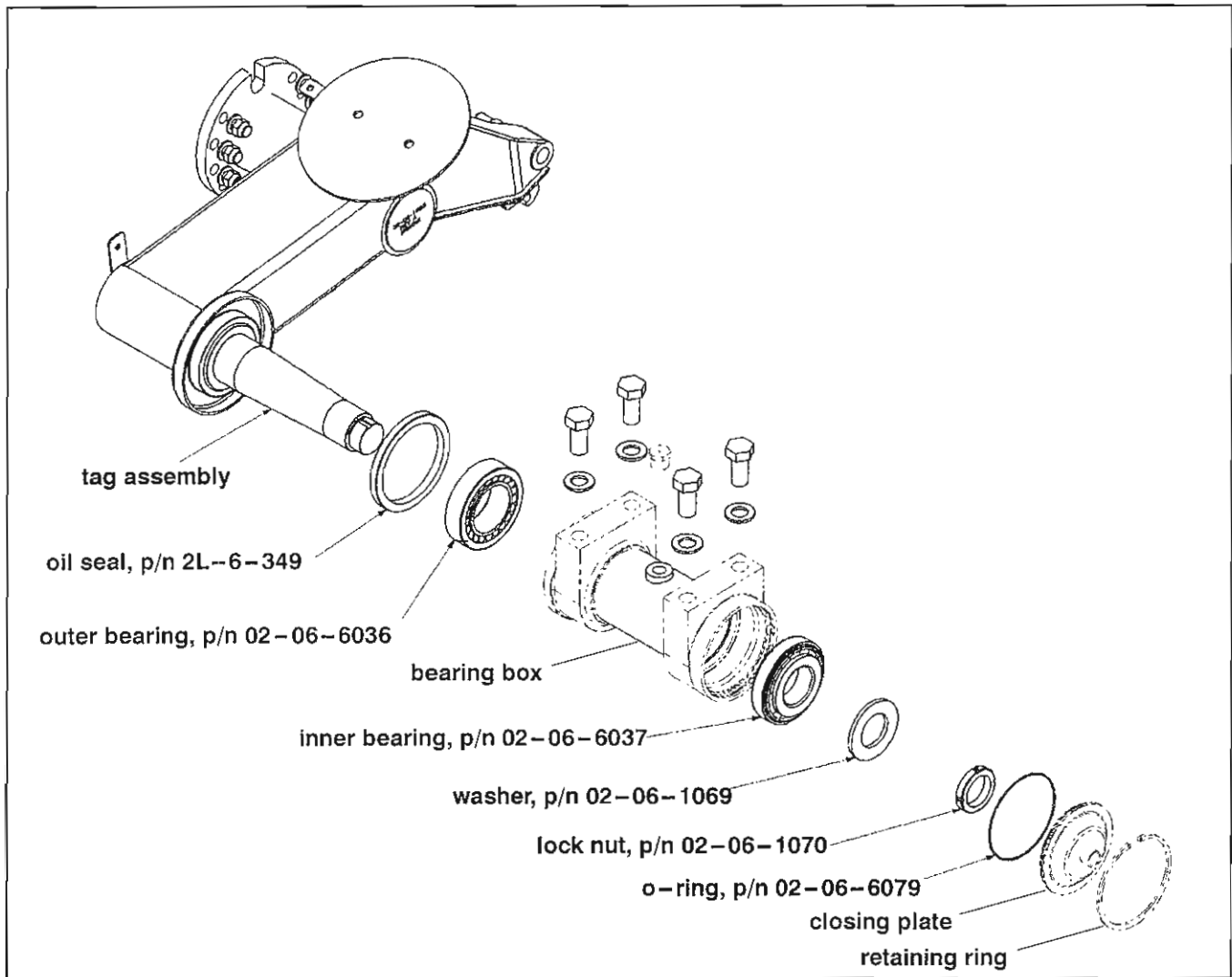

**Figure 4.**

12. Torque nut ( p/n 02-06-1070 ) to 95-105 ft-lbs while rotating or rocking the suspension arm. Back-off and re-torque to 19-22 ft-lbs while rotating the arm. Torque lock nut set screw to 5-7 ft-lbs.

13. Mount a dial indicator magnetic base to the side of the bearing box. Position the indicator against the end of the arm trunnion shaft to monitor the end play of the bearings. Using a pry bar and light controlled force, push the tag axle arm back and forth laterally, and monitor the dial indicator for bearing end play. If bearing end play is more than 0.005 or less than 0.001, loosen the shaft nut and repeat Step 12. until end play is measured between 0.001 and 0.005 inch.
14. Install new o-ring ( p/n 02-06-6079 ) on bearing box.
15. Re-install closing plate and retaining ring.
16. Fill bearing box with gear lube ( p/n 21-7512-2 ). Check fill level and add as required to completely fill.
17. Push the ABS sensor completely into sensor bushing by hand until it stops against the tone ring. The ABS sensor is properly installed and adjusted when it is touching the tone ring.



## NOTE

***The ABS sensor must slide freely in and out of the mounting sleeve bore. Operating the vehicle with seized components will damage the speed sensor and the tone ring.***

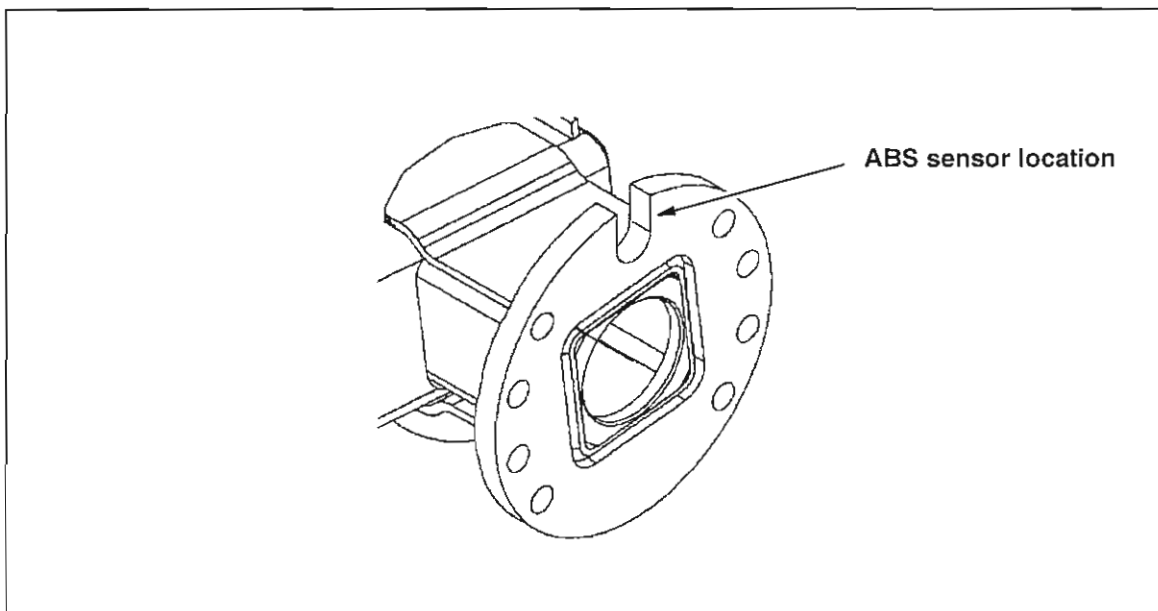

**Figure 5.**

18. Fasten the air spring to the chassis mounting pads. Torque air spring mounting fasteners to 50 lb-ft
19. Re-connect the air lines from tag axle suspension air spring bellows and brake chamber air fittings.
20. Re-assemble the shock absorber to the tag axle arm and torque the nut until the bushing retaining washer bottoms out on the shoulder bolt. Re-install the wheel assembly. Torque all wheels to 450-500 lb-ft ( 610-678 Nm ) using an alternating sequence as outlined in the maintenance manual.



## REFER TO MANUAL

***Refer to the Maintenance Manual / Section 15 / Wheels, Hubs and Tires, for the basic procedures on wheel installation, torque and torque sequence.***

21. Check for air leaks and proper bellows operation.
22. Repeat Steps 8. to 21. for the opposite side tag axle.
23. Test drive the vehicle and verify that the ABS warning lamp operates properly.

***Procedure complete for coaches where NO cracks were found upon inspection.***

Steps 24 to 54 cover the installation of new tag axle arms where CRACKS ARE FOUND upon inspection



## NOTE

*Step 24. ( listed below ) is a continuation of Steps 1 to 7. at the beginning of this Service Bulletin (as it relates to the tag axle arm removal part of this bulletin ).*

24. Back off the slack adjuster ( counter-clockwise ) and remove brake drum. Carefully clean any brake dust from inside drum using a clean cloth moistened with " Brake Kleen " or similar cleaner.



## NOTE

**DO NOT use compressed air to clean brake components.**

25. Remove hub cap and carefully drain oil from hub into an appropriate container. Dispose of the oil in an appropriate manner.
26. Remove wheel bearing adjusting nut and lockwashers. Carefully remove the hub from the spindle, taking care to prevent the bearings from becoming contaminated, and to prevent oil from contaminating brake shoes. Set aside to be re-installed at a later step in this procedure.
27. Remove the 8 capscrews mounting the brake spider and spindle to the spindle mounting plate. Retain fasteners, to be re-installed at a later step in this procedure. Set aside any shims mounted between the spindle and the mounting plate.
28. Remove the drain plug and drain the oil from the bearing box. Dispose of the oil in an appropriate manner.
29. Remove the fasteners that mount the bearing box to the bogie leg. Retain the fasteners, to be re-installed at a later step in this procedure.
30. Remove and retain the retaining ring and closing plate from the bearing box assembly ( Figure 4 ). Remove and discard the o-ring from the bearing box. Remove and discard the shaft nut and washer from the end of the tag axle arm trunnion shaft.

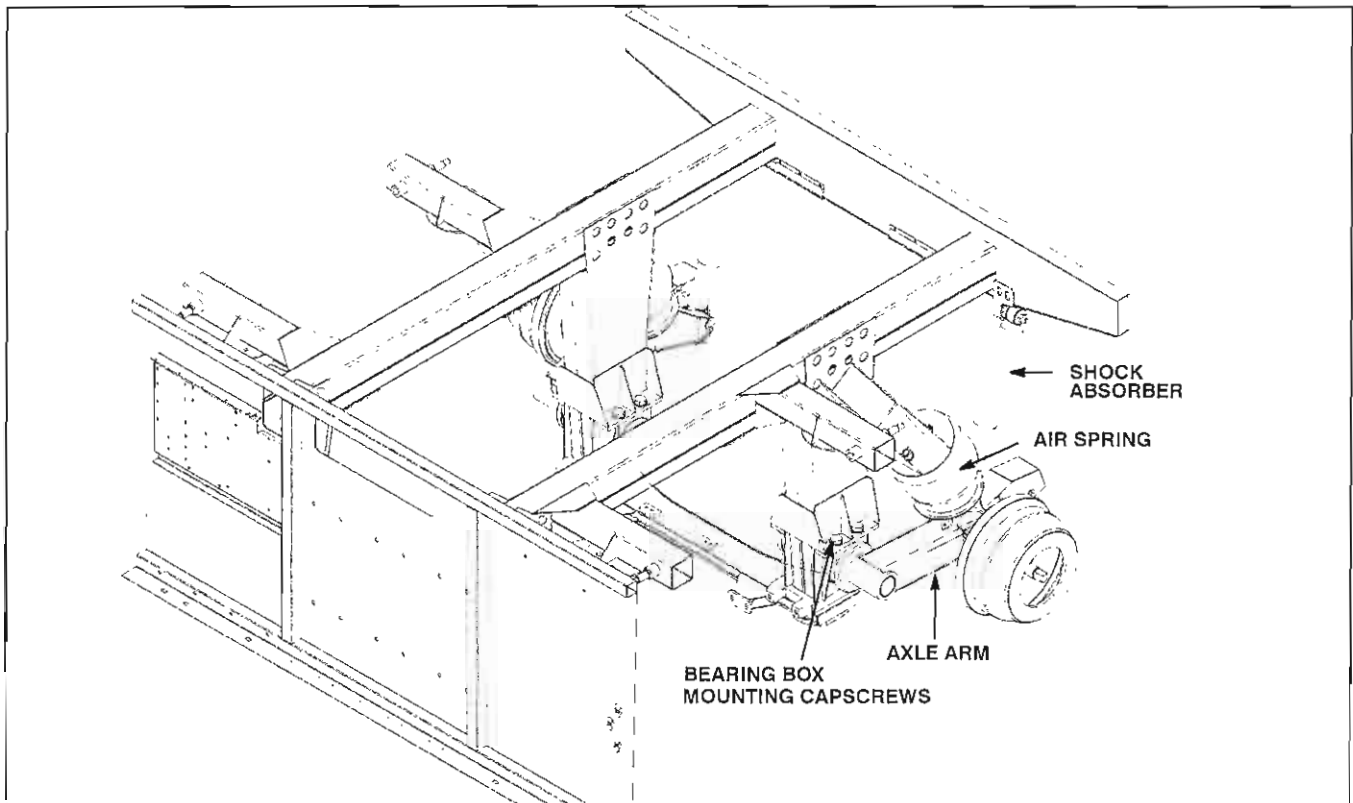

Figure 6. Tag axle arm.

31. Remove the tag axle arm assembly from the coach.



### **REFER TO MANUAL**

*Refer to the MCI G Series Maintenance Manual, for the basic rules, procedures and safety precautions that must be followed before air spring, bearing box and hub assembly removal / installation.*



### **REFER TO MANUAL**

*Refer to Section 2B / Trailing Axle in the MCI G Series Maintenance Manual, for information relating to bearing box removal / installation.*



### **NOTE**

*Inspect the tag axle bearing box bearings, ensuring that they are free of rust, that no pitting has occurred and they roll freely.*

32. Remove the bearing box from the arm.



### **NOTE**

*Install new bearing cup, p/n 02-06-1052, in the outer end of the box, next to the tag axle arm.*

33. Carefully remove bearing cups from bearing box, ensuring no damage to the bearing box. Discard existing bearings. Install new bearings ( p/n 02-06-6037 and 02-06-1052 ) into bearing box.
34. Insert the cone of the outer bearing, p/n 02-06-1052, into the outer race and carefully press the new oil seal ( part number 2L-6-349 ) into the housing of the box.
35. After lubricating the inner lips of the seal, install bearing box assembly onto the new tag arm assy. Take care to prevent side loading the seal as the box is being assembled to prevent damage to the seal. Install the inner race of the inner bearing, p/n 02-06-6037, washer, p/n 02-06-1069 and lock nut ( p/n 02-06-1070 ) ( Figure 7 ). Torque the lock nut to 95-105 lb-ft while rotating the bearing box. Back off, and re-torque to 19-22 lb-ft, while again rotating the bearing box. Torque lock nut set screw to 5-7 ft-lbs.
36. Mount a dial indicator magnetic base to the side of the bearing box. Position the indicator against the end of the arm trunnion shaft to monitor the end play of the bearings. Using a pry bar and light controlled force, push the tag axle arm back and forth laterally, and monitor the dial indicator for bearing end play. If bearing end play is more than 0.005 or less than 0.001, loosen the shaft nut and repeat Step 35. until end play is measured between 0.001 and 0.005 inch.
37. Install the new o-ring ( part number 02-06-6079 ). Carefully install the end cap and retaining ring.



### **NOTE**

*Ensure that the retaining ring is properly seated.*

38. Fill bearing box with gear lube ( p/n 21-7512-2 ). Check fill level and add as required to completely fill.



### **NOTE**

*Ensure that bearing box stays mounted upright to prevent oil loss.*

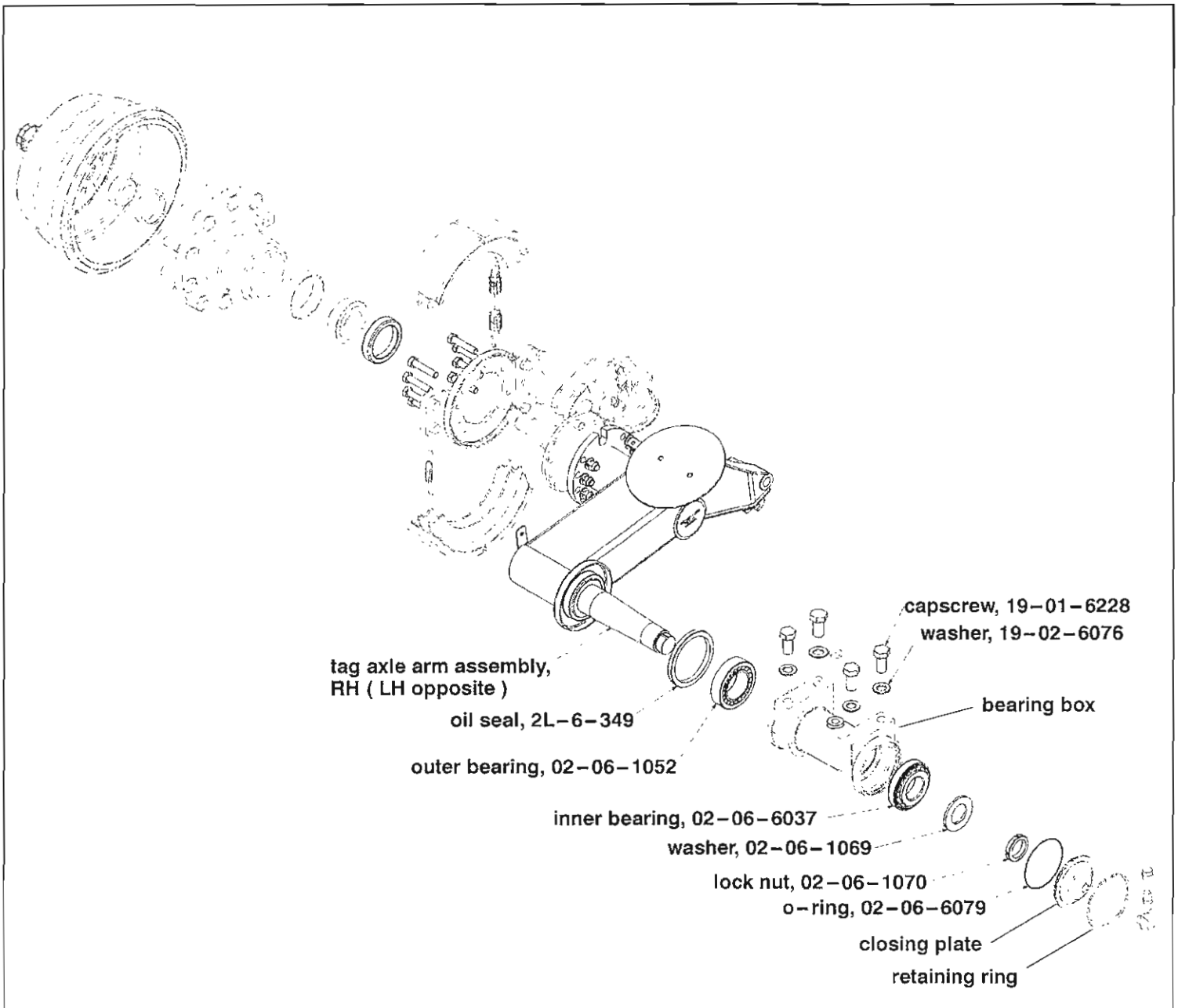

Figure 7. Tag axle arm assembly, RH.

39. Install new tag axle arm ( p/n 02-06-1034 and 02-06-1056 ), taking care not to allow oil to drain from bearing box. Torque the bearing box mounting capscrews to 300–310 lb-ft.
40. Re-assemble the brake assembly, spider, and spindle to the new tag axle arm, using the 8 capscrew previously removed in Step 27. Take care to ensure that the ABS sensor hole in the spindle is aligned with the slots in the brake spider and the top of the spindle mounting plate. DO NOT install any shims at this time. Shims are used to correct any misalignment observed when the coach is aligned.
41. Replace brake hardware kit ( S-cam rollers and springs ), carefully applying brake grease to the contact points between rollers and brake shoes. DO NOT apply grease to the contact surface between rollers and S-cam. Check to ensure that the S-cam is properly located at this time.

42. Replace wheel bearing hub seal ( part number 15-05-6038 ). Press the new seal into the hub. Be sure that inner bearing cone is installed into the hub before the seal is pressed in.
43. Install the hub onto the spindle, taking care to support and align the hub so that the hub seal is not damaged. Install the outer wheel bearing, flatwasher, adjusting nut and retaining washer. Torque the adjusting nut to 100 lb-ft while rotating the hub. Back off the adjusting nut 1 full turn. Re-torque to 50 lb-ft while rotating the hub. Back off 1/4 turn. Torque outer jam nut to 300–400 lb-ft. Using a dial indicator, verify that end play is 0.001–0.005 inch.
44. Torque hub cap bolts to 13–15 lb-ft ( Figure 5 ). Fill hub cavity until gear oil ( part number 23-01-0029 ) appears at the level mark of the hub cap's plastic sight glass. Reinstall the rubber plug, and recheck level after coach operation. DO NOT overfill the hubs.
45. Carefully install the brake drum.
46. Adjust slack adjuster by turning the adjusting screw clockwise until brake shoes contact the drum. Back off 1/2 turn, plus any backlash observed.



## NOTE

Replace the hub cap gasket ( part number 15-05-6036 ) and hub oil seal ( part number 15-05-6038 or 15L-5-167 ) after every hub assembly / disassembly ( Figure 5 ).

The slack adjuster will have to be backed off to allow for brake drum removal.

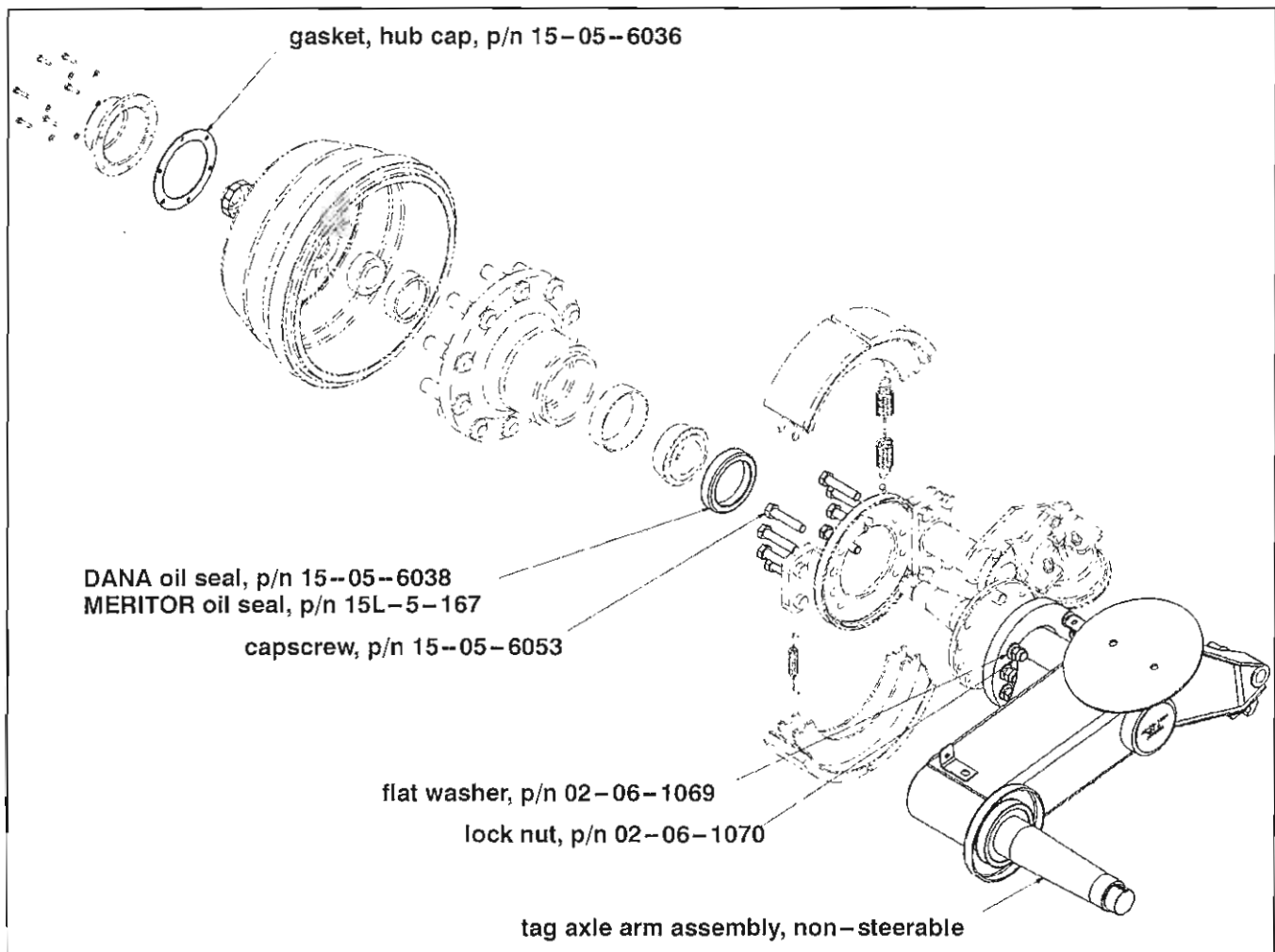

Figure 8. Wheel end components.

47. Push the ABS sensor completely into sensor bushing by hand until it stops against the tone ring. The ABS sensor is properly installed and adjusted when it is touching the tone ring ( Figure 5 ).



### **NOTE**

***The ABS sensor must slide freely in and out of the mounting sleeve bore. Operating the vehicle with seized components will damage the speed sensor and the tone ring.***

48. Fasten the air spring to the chassis mounting pads. Torque air spring mounting fasteners to 50 lb-ft.  
49. Reconnect the air lines from tag axle suspension air spring bellows and brake chamber air fittings.  
50. Re-assemble the shock absorber to the tag axle arm and torque the nut until the bushing retaining washer bottoms out on the shoulder bolt. Re-install the wheel assembly. Torque all wheels to 450–500 lb-ft ( 610–678 Nm ) using an alternate sequence as outlined in the maintenance manual.



### **REFER TO MANUAL**

***Refer to the Maintenance Manual / Section 15 / Wheels, Hubs and Tires, for the basic procedures on wheel installation, torque and torque sequence.***

51. Verify proper brake function by starting the coach, building up air pressure and verifying that full brake strokes are obtained when the brake pedal is applied. Verify that the brake stroke does not exceed CVSA re-adjustment limits.



### **NOTE**

***The CVSA power stroke re-adjustment limits for type 20 brake chambers is 1.75 inches.***

***The power stroke measurement is the difference between the brakes fully applied and fully released***

***If the power stroke does not exceed the CVSA readjustment limits for the chamber size, then the power stroke inspection is complete.***

***If the power stroke exceeds the allowable stroke for the chamber size, the cause of the overstroke condition must be identified and corrected. The power stroke should be retested to confirm compliance.***

52. Check for air leaks and proper bellows operation.  
53. Repeat Steps 24. to 52. for the opposite side tag axle, installing new tag axle arm ( p/n 02-06-1071 or 02-06-1054 ).  
54. Test drive the vehicle and verify that the ABS warning lamp operates properly.



### **NOTE**

***Verify proper brake function, ensuring correct brake installation.***

***Note that up to 20 brake applications while to vehicle is operating may be required to have the automatic slack adjusters properly adjust the brake clearance.***

***Be sure that several brake applications are made under light load in an open location to avoid problems while the slack adjuster is making initial adjustments.***

*Procedure complete.*



**DO NOT PROCEED PRIOR TO READING**

**THE ALIGNMENT PROCEDURE LISTED BELOW IS ONLY REQUIRED FOR COACHES THAT HAVE NEW TAG AXLE ARMS INSTALLED.**

**IF ALIGNMENT IS REQUIRED, THE OIL SEALS, O-RINGS AND HUB CAP GASKET WILL HAVE TO BE REPLACED, AS THEY ARE A ONE TIME USE ITEM.**

**ALIGNMENT: TAG AXLE**

Periodic inspection of the axle assembly should be made to see that all wheel end spindle flange and/or bearing box mounting hardware are tight and that no damage or distortion has taken place.



**NOTE**

**All suspension mounting hardware should be checked and tightened to the torque specifications shown in sub-section 12A.**

The following alignment specifications are provided as a general guide only. Toe-in – ( 0.03" ± 0.03" ), or approximately 1/64 inch per wheel end when measured relative to the coach centerline. Alignment – ( 0.25 degree positive ± 0.44 degrees ). Tag axle wheel track is 84.9 inches ( 2156 mm ) at center of tread. Coaches with a Toe-In/Toe-Out condition, beyond that of limit shown above should be re-aligned.

If the toe measurement is out of specification more than 0.62" on a side, the bearing box must be adjusted on the chassis. Loosen the four bearing box mounting bolts and rotate the box in the direction needed. Take a preliminary alignment measurement to aid in locating box correctly. Tighten the mounting bolts to the proper torque value and ensure that bolts are seated properly.

If the toe measurement is out of specification less than 0.62" per side, adjust the wheel end using shims. Install only one of these shims per side of the vehicle ( Figure 9 ). Disassemble tag wheel end and install shim between swing arm and wheel spindle. Reassemble wheel end. Torque all components to the proper torque value and verify alignment is within specifications. Fill the hub with oil.

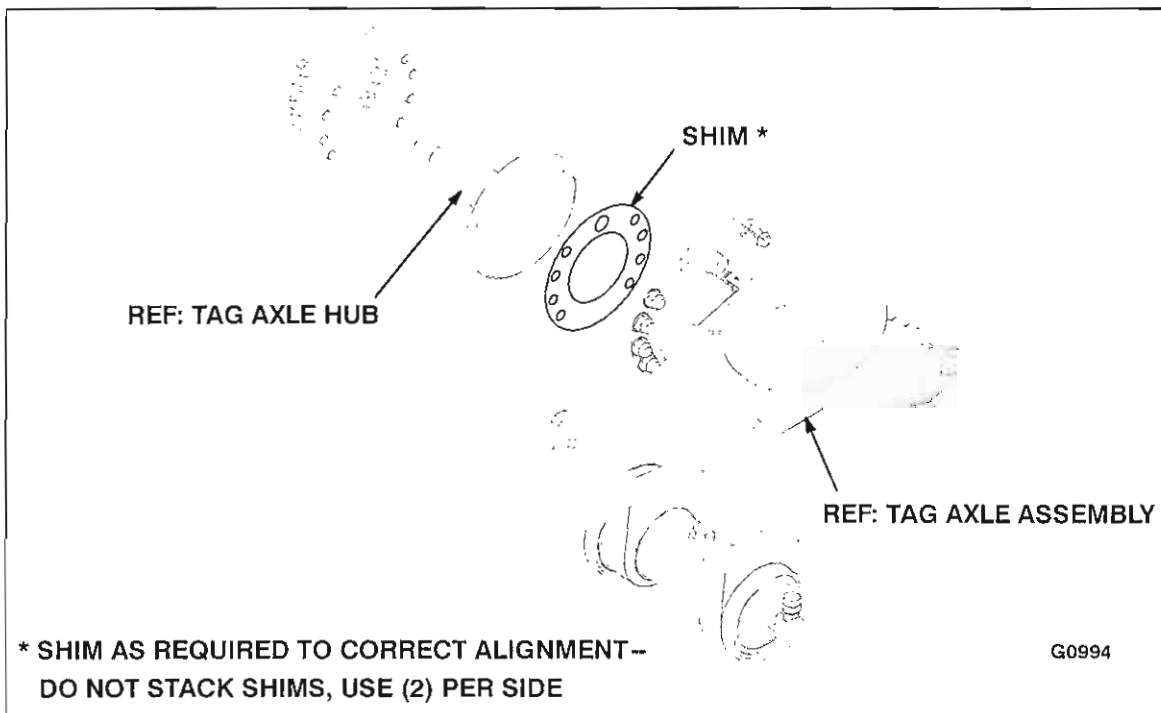

**Figure 9. Tag Axle Shim Installation.**

**ALIGNMENT: TAG AXLE**

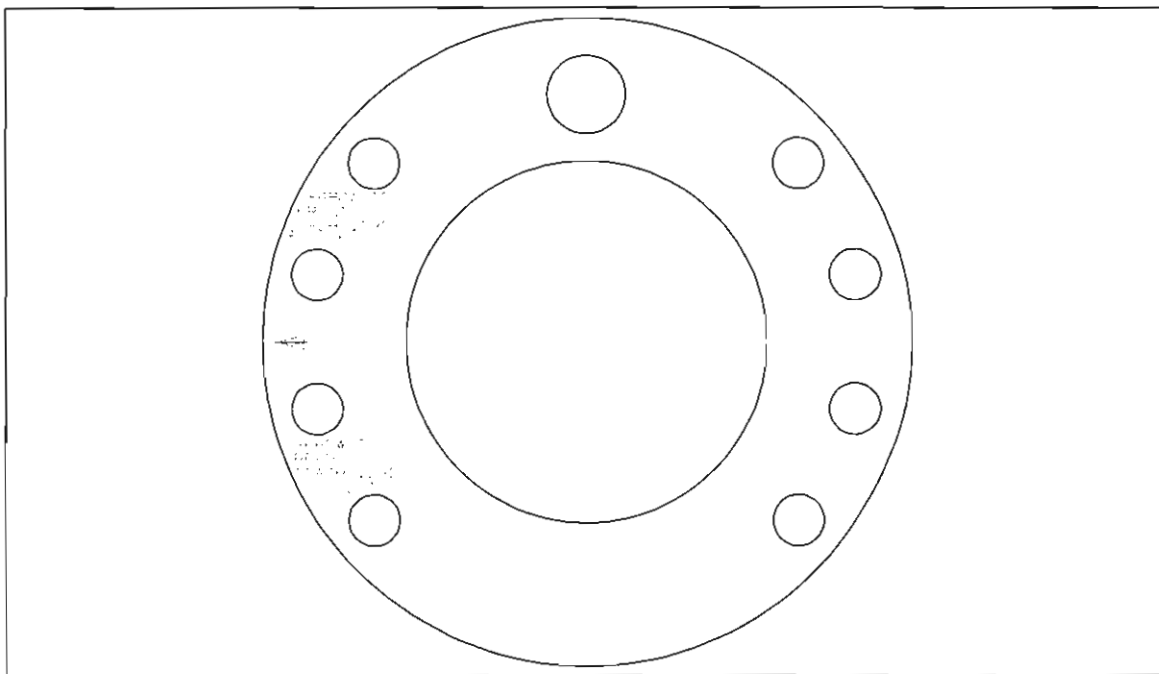

Figure 10. Tag Axle Shim.



**NOTE**

*Only 2 shims allowed per side.  
Tag Axle Alignment Procedure complete.*

*Procedure complete.*

Mail or fax the completed warranty claim form to MCI's warranty department, or photocopy and mail it to:

MCI Fleet Support  
Attn: Warranty Department  
7001 Universal Coach Drive  
Louisville, KY 40258  
Fax Number 1-800-360-8886

to receive credit for the hours used to complete this task. Contact the MCI Fleet Support Technical Center at 1-800-241-2947 for any further information.

***Field Change Program Conditions:***

The parts required for this change will be supplied without charge.

A labor allowance of 4.0 hours will be granted against claim SB289.1, for the procedure of inspecting and installing hardware kit on existing tag axle arms on G4500 model coaches.

A labor allowance of 19.0 hours will be granted against claim SB289.2, for the procedure of installing a new LH and RH tag axle arm on G4500 model coaches. An allowance of 2 hours for the alignment of the tag axle on G4500 model coaches is included in the 19.0 labor allowance.

This labor allowance will be credited to your MCI Fleet Support Parts Account on receipt of a "Warranty Claim Form" as detailed in your Owner Warranty manual.

Motor Coach apologizes for any inconvenience resulting from this campaign, but urges you to implement this change as soon as possible.

Sincerely,

*Motor Coach Industries*  
U.S. and Canadian Service Departments.