

DAIMLER



Daimler Trucks North America
Nasser Zamani
Manager
Compliance and Regulatory Affairs

July 3, 2008

Dan Smith
Associate Administrator for Vehicle Safety
National Highway Traffic Safety Administration
1200 New Jersey Avenue S.E.
Washington D.C. 20590

**Re: Defect Information Report – Supplemental Report No. 2
08V-085, FL-523, M2 Front Side Reflex Reflectors**

Mr. Smith

In accordance with Part 573 of Title 49 of the Code of Federal Regulations, Daimler Trucks North America LLC herewith submits supplemental defect information and copies of documents to be distributed to dealers and purchasers.

- (c)(3) Total number of vehicles potentially affected: 1,998**
- (c) (8)(ii) Communications sent to dealers:** posted June 6, 2008
Communications sent to owners: mailed June 12, 2008
- (c) (10) Copies of Communications sent to owners and dealers are attached.**

Please contact me if you have any questions.

Sincerely yours,

Nasser Zamani

Cc: Michael Mason, CAL-OSHA
Enclosure
Certified Mail# 7004 2890 0004 1202 2076

A Daimler Company

Daimler Trucks North America LLC
4747 N. Channel Avenue
Portland OR 97217-7699
503-745-6910 Phone
503-745-5544 Fax
NasserZamani@Freightliner.com

Subject: Business Class M2 Front Side Reflex Reflectors

Models Affected: Specific Freightliner Business Class M2 vehicles manufactured between July 7, 2004, and January 15, 2008.

General Information

Daimler Trucks North America LLC, on behalf of its Freightliner Trucks Division, has decided that the vehicles mentioned above fail to conform to the requirements of Federal Motor Vehicle Safety Standard No. 108, "Lamps, Reflective Devices, and Associated Equipment."

There are approximately 2,300 vehicles involved in this campaign.

Certain vehicles may have been built without front side reflex reflectors required by FMVSS 108 or CMVSS 108. Under certain conditions, this may lead to impaired visibility of the truck to other vehicles, resulting in a possible vehicle crash without prior warning.

Front side reflex reflectors will be installed on the vehicles.

Additional Repairs

Dealers must complete all outstanding recall and field service campaigns prior to the sale or delivery of a vehicle. A Dealer will be liable for any progressive damage that results from its failure to complete campaigns before sale or delivery of a vehicle.

Owners may be liable for any progressive damage that results from its failure to complete campaigns within a reasonable time after receiving notification.

Work Instructions

Please refer to the attached work instructions. Prior to performing the campaign, check the vehicle for a completion sticker (Form WAR260).

Replacement Parts

Replacement kits are now available and can be obtained by ordering the kit number(s) listed below from your facing Parts Distribution Center.

If our records show your dealership has ordered any vehicles involved in campaign number FL523A, a list of the customers and vehicle identification numbers will be available on AccessFreightliner.com. Please refer to this list when ordering parts for this recall.

Table 1 - Replacement Parts for FL523

Campaign Number	Kit Number	Part Description	Part Number	Qty. per Kit	Suggested Wholesale*
FL523A	25-FL523-000	Reflex Reflector	TL 98001Y	2 ea	\$7.63 U.S. \$7.63 CAN
		Washer	23-10900-010	4 ea	
		Hexnut	23-13224-004	4 ea	
		Screw	23-12642-725	4 ea	
		Completion Sticker	WAR260	1 ea	

* Please charge all Direct Warranty Customers the above-listed price for the kit, as they are authorized to perform their own Recalls.

Table 1

Recall Campaign

Daimler Trucks
North America LLC

June 2008
FL523A
NHTSA #08V-085

Removed Parts

Please follow Warranty Failed Parts Tracking shipping instructions for the disposition of all removed parts.

Labor Allowance

Table 2 - Labor Allowance

Campaign Number	Procedure	Time Allowed (hours)	SRT Code	Damage Code
FL523A	Install front side reflex reflectors	0.4	996-0754A	000-Modifiedx

Table 2

IMPORTANT: When the recall has been completed, locate the base completion label in the appropriate location on the vehicle, and attach the red completion sticker provided in the recall kit (Form WAR260). If the vehicle does not have a base completion label, clean a spot on the appropriate location of the vehicle and first attach the base completion label (Form WAR259). If a recall kit is not required or there is no completion sticker in the kit, write the recall number on a blank sticker and attach it to the base completion label.

Claims for Credit

You will be reimbursed for your parts, labor, and handling by submitting your claim through the Warranty system within 30 days of completing this campaign. Please reference the following information in QuickClaim®:

- Claim type is **Recall**.
- In the FTL Authorization field, enter the campaign number and appropriate condition code (**FL523A**).
- In the Primary Failed Part Number field, enter **25-FL523-000**.
- In the Parts field, enter the appropriate kit number(s) as shown in the Replacement Parts Table.
- In the Labor field, first enter the appropriate SRT from the Labor Allowance Table. For administrative time, enter SRT 939-0010A for 0.3 hours.
- **Reimbursement for Prior Repairs.** When a customer asks about reimbursement, please do the following.
 - Accept the documentation of the previous repair.
 - Make a brief check of the customer's paperwork to see if the repair may be eligible for reimbursement. (See the "Copy of Owner Letter" section of this bulletin for reimbursement guidelines for this recall.)
 - Contact the Warranty Campaigns Department for a decision and authorization number.
 - Include the approved amount on your claim in sublet/outside purchases.
 - In the claim story, first note the authorization number and that the claim includes a reimbursement request.
 - Retain the documentation and provide it to Warranty Campaigns or Claims Processing if requested.
 - When your claim is paid, reimburse the customer the appropriate amount.

IMPORTANT: ServicePro® must be viewed prior to performing the recall to ensure the vehicle is involved and the campaign has not been previously completed. Also, check for a completion sticker prior to beginning work.

Contact the Warranty Campaigns Department at (800) 547-0712, from 7:00 a.m. to 4:00 p.m. Pacific Time, Monday through Friday, Web inquiry at AccessFreightliner.com / Support / Submit an Inquiry, or the Customer Assistance Center at (800) 385-4357, after normal business hours, if you have any questions or need additional information.

To return excess kit inventory related to this campaign, U.S. dealers must submit a Parts Authorization Return (PAR) to the Memphis PDC. Canadian dealers must submit a PAR to their facing PDC. All kits must be in resalable condition. PAR requests must include the original purchase invoice number.

The letter notifying vehicle owners is included for your reference.

Please note that the National Traffic and Motor Vehicle Safety Act, as amended (Title 49, United States Code, Chapter 301), requires the owner's vehicle(s) be corrected within a reasonable time after parts are available to you. The Act states that failure to repair a vehicle within 60 days after tender for repair shall be prima facie evidence of an unreasonable time. However, circumstances of a particular situation may reduce the 60 day period. Failure to repair a vehicle within a reasonable time can result in either the obligation to (a) replace the vehicle with an identical or reasonably equivalent vehicle, without charge, or (b) refund the purchase price in full, less a reasonable allowance for depreciation. The Act further prohibits dealers from selling a vehicle unless all outstanding recalls are performed. Any lessor is required to send a copy of the recall notification to the lessee within 10 days. Any subsequent stage manufacturer is required to forward this notice to its distributors and retail outlets within five working days.

Recall Campaign

Daimler Trucks
North America LLC

June 2008
FL523A
NHTSA #08V-085

Copy of Letter to Owner

Subject: Business Class M2 Front Side Reflex Reflectors

This notice is sent to you in accordance with the requirements of the National Traffic and Motor Vehicle Safety Act. This notice is also sent in accordance with the Canadian Motor Vehicles Safety Act.

Daimler Trucks North America LLC, on behalf of its Freightliner Trucks Division, has decided that specific Freightliner Business Class M2 vehicles manufactured between July 7, 2004 and January 15, 2008, fail to conform to the requirements of Federal Motor Vehicle Safety Standard No. 108, "Lamps, Reflective Devices, and Associated Equipment."

Certain vehicles may have been built without front side reflex reflectors required by FMVSS 108 or CMVSS 108. Under certain conditions, this may lead to impaired visibility of the truck to other vehicles, resulting in a possible vehicle crash without prior warning.

Front side reflex reflectors will be installed on the vehicles.

Parts are now available for authorized dealers to order. Contact your authorized dealer to arrange to have your vehicle(s) modified and to assure that parts are available at the dealer. To locate a dealer, search online at www.FreightlinerTrucks.com or contact the Warranty Campaigns Department for assistance.

When you contact your dealer, refer to campaign number **FL523A**. Once kit(s) are received at the dealership, the Recall will take approximately forty-five minutes and will be performed at no charge to you.

IMPORTANT: When the Recall has been completed, please ensure that a label has been affixed to your vehicle referencing **FL523A**.

If you do not own the vehicle that corresponds to the identification number(s) which appears on the Recall Notification, please return the notification to the Warranty Campaigns Department with any information you can furnish that will assist us in locating the present owner. If you have leased this vehicle, Federal law requires that you forward this notice to the lessee within 10 days. If you are a subsequent stage manufacturer, Federal law requires that you forward this notice to your distributors and retail outlets within five working days. If you have paid to have this recall condition corrected prior to this notice, you may be eligible to receive reimbursement. Please see the reverse side of this notice for details.

If you are not able to have the defect remedied without charge and within a reasonable time, which is not longer than 60 days after you tender the vehicle for repair, please contact the Warranty Campaigns Department at (800) 547-0712, 7:00 a.m. to 4:00 p.m. Pacific Time, Monday through Friday, e-mail address WarrantyCampaigns@freightliner.com, or the Customer Assistance Center at (800) FTL-HELP or (800) STL-HELP, after normal business hours. You may also wish to submit a complaint to the Administrator, National Highway Traffic Safety Administration, 1200 New Jersey Avenue, SE., Washington, DC 20590; or call the Vehicle Safety Hotline at (888) 327-4236 (TTY: 800-424-9153); or to <http://www.safercar.gov>. If your vehicle is involved in the Canadian portion, you may wish to notify Transport Canada, ASFAD, Place de Ville Tower C, 330 Sparks Street, Ottawa, ON K1A 0N5, or phone (800) 333-0510.

We regret any inconvenience this action may cause but feel certain you understand our interest in motor vehicle safety.

WARRANTY CAMPAIGNS DEPARTMENT

Enclosure

Reimbursement to Customers for Repairs Performed Prior to Recall

If you have already **paid** to have this recall condition corrected you may be eligible to receive reimbursement.

Requests for reimbursement may include parts and labor. Reimbursement may be limited to the amount the repair would have cost if completed by an authorized Daimler Trucks North America LLC dealer. The following documentation must be presented to your dealer for consideration for reimbursement.

Please provide original or clear copies of all receipts, invoices, and repair orders that show:

- The name and address of the person who paid for the repair.
- The Vehicle Identification Number (VIN) of the vehicle that was repaired.
- What problem occurred, what repair was done, when the repair was done.
- Who repaired the vehicle.
- The total cost of the repair expense that is being claimed.
- Proof of payment for the repair (such as the front and back of a cancelled check or a credit card receipt).

Reimbursement will be made by check from your Daimler Trucks North America LLC dealer.

Please speak with your Daimler Trucks North America LLC authorized dealer concerning this matter.

June 2008
FL523A

NHTSA #08V-085

Work Instructions

Subject: Business Class M2 Front Side Reflex Reflectors

Models Affected: Specific Freightliner Business Class M2 vehicles manufactured between July 7, 2004, and January 15, 2008.

Reflex Reflector Installation Procedure

1. Check the base label (Form WAR259) for a completion sticker for FL523 (Form WAR260) indicating this work has been done. The base label is usually located on the passenger-side door about 12 inches (30 cm) below the door latch. If a sticker for FL523 is present, nothing further needs to be done. If no sticker is present, go to the next step.
2. Shut down the engine, set the parking brake, and chock the tires.
3. Mark both the LH and RH sides of the hood for drilling holes, as shown in **Fig. 1**. Make sure the marks are correctly aligned so that the reflectors will be vertical. If needed, place a level between the marks.
4. Open the hood to ensure a clear area on both sides in which to drill the holes.

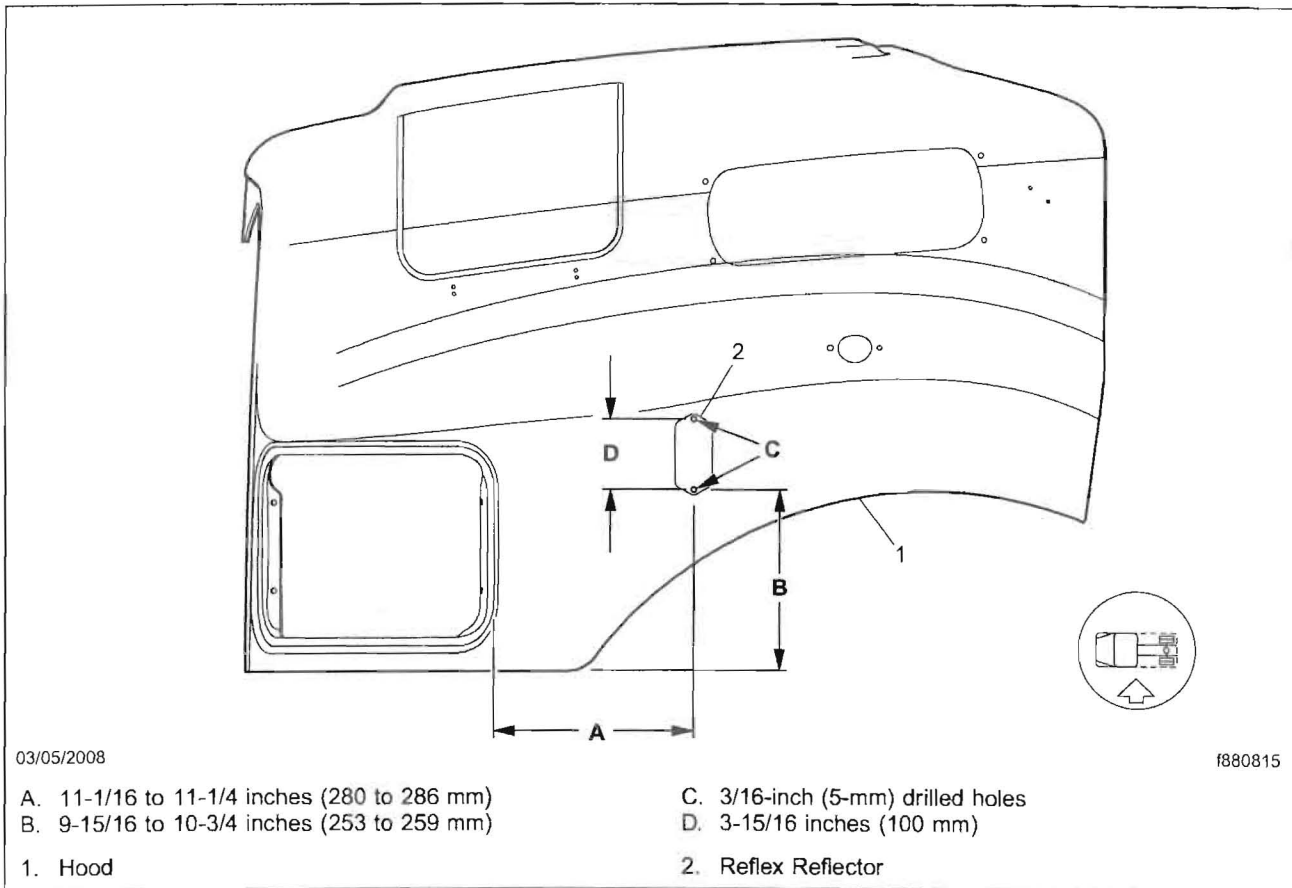

Fig. 1, Measurements for Reflex Reflector Installation (left side shown)

5. Close the hood, and using a 3/16-inch (5-mm) drill bit, drill the holes as previously marked.
6. On one side of the vehicle, install the reflex reflector as follows.
 - 6.1 Clean and dry the area where the reflector will be installed.
 - 6.2 Remove the backing from the reflector, then aligning the holes in the reflector with those drilled into the hood, adhere the reflector to the hood.
 - 6.3 Install the two washers and screws from the kit in the reflector and the hood surface.
7. Install the reflex reflector on the other side of the vehicle following the steps listed above.
8. Open the hood, and from inside the hood, install the flanged hexnuts from the kit on the screws. You will need to work between the inner fender and the hood surface on each side of the vehicle. See **Fig. 2**. Tighten the hexnuts 20 lbf-in (2 N·m).

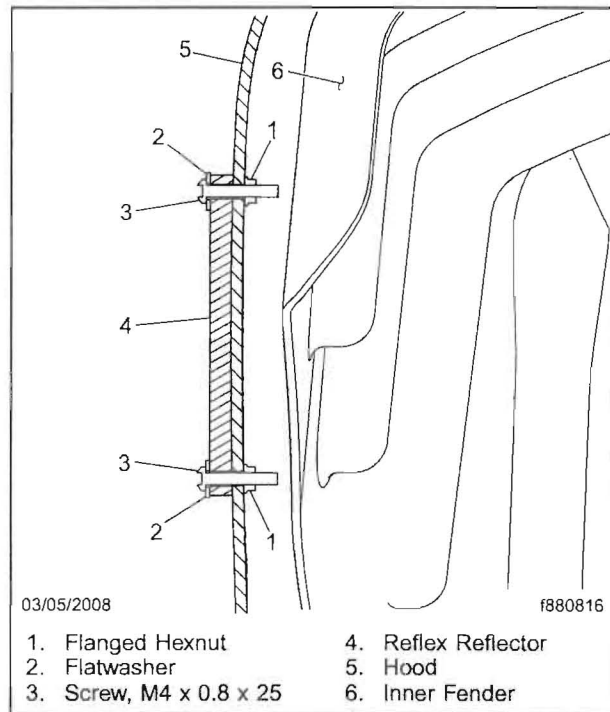

Fig. 2, Reflex Reflector Installation (cross-section view, hood tilted)

9. Close the hood.
10. Clean a spot on the base label (Form WAR259). Attach a completion sticker for FL523 (Form WAR260) to the base label.
11. Remove the chocks.