



Fleetwood Enterprises, Inc.
3030 Myers Street / Riverside, CA 92503-5527
P.O. Box 7638 / Riverside, CA 92513-7638
p: 800.322.8216 / www.fleetwoodrv.com

IMPORTANT RECALL INFORMATION #80211

March, 2008

**TO: ALL FLEETWOOD DEALER PRINCIPALS,
SERVICE MANAGERS
AND PARTS MANAGERS**

**SUBJECT: RECALL CAMPAIGN #80211
2008 TERRA & FIESTA MOTOR HOME
ENTRY STEP ATTACHMENT CRADLE/SUPPORT**

Fleetwood Enterprises, Inc., on behalf of its subsidiary manufacturing centers located in Riverside, California and Paxinos, Pennsylvania is requesting your assistance in conducting a voluntary recall notification campaign in accordance with the National Traffic and Motor Vehicle Safety Act.

Fleetwood Enterprises, Inc., has decided that a defect which relates to motor vehicle safety exists in certain 2008 model year Terra and Fiesta model motor homes. We are notifying owners in order to correct the problem. A copy of the letter sent to owners is enclosed for your information.

WHAT IS THE PROBLEM?

On certain 2008 Fiesta and Terra model motor homes affected by this recall, the entry step attachment cradle/support may bend as a result of step usage and insufficient structural material strength, possibly resulting in risk of personal injury, vehicle and/or other property damage.

WHAT SHOULD YOU DO?

Owners of the above mentioned motor homes have been asked to contact a Fleetwood dealer to have the described defect remedied. In the event that you are contacted by a customer, please verify eligibility by referring to the serial number range listed in the enclosed Recall Service Bulletin #80211 prior to beginning the repairs.

Once repairs are completed, have the customer sign your dealership's Internal Repair Order and submit your request electronically through e-FDN, or you may also have the customer sign the Fleetwood Repair Order (form X-SR-042) and submit for reimbursement in accordance with Service Bulletin #80211. Customers will not be charged for these repairs.

If you have one of these vehicles in your inventory, you will be mailed a Safety Recall Notice for that specific motor home. Fleetwood is asking our dealers to make repairs to stock units on dealer lots prior to sale or lease.

Federal Law (Section 154 of the National Highway Traffic and Motor Vehicle Safety Act of 1966 requires that: If you have received a notice of recall or failure to comply from Fleetwood or any component manufacturer, you must repair or otherwise correct the defects on vehicles remaining in your inventory according to the notification, before selling or leasing the vehicles. Any vehicle lessor receiving this recall notice must forward a copy of the notice to the lessee within ten days.

Please review this entire package with your parts and service staff to familiarize them with the step-by-step procedure and implement the Voluntary Safety Recall Campaign.

Thank you for helping Fleetwood with its continuing efforts to maintain customer satisfaction. If you have any questions, please contact your regional Fleetwood Service Center.

Sincerely,

FLEETWOOD ENTERPRISES, INC.

A handwritten signature in cursive script that reads "Tina Inkrote".

Tina Inkrote
Service Administrator
Motor Home Division

Enclosures: Recall #80211 Customer Letter
Recall #80211 Service Bulletin

Recall Bulletin 80211



**RECALL
BULLETIN:**
80211

**YEAR(S)
AFFECTED:**
2008

**PRODUCT(S)
AFFECTED:**
Fiesta,
Terra,
with serial
numbers listed
in this Bulletin

**MODEL(S)
AFFECTED:**
All

SUBJECT:
Reinforce
the Entry
Step Cradle

KEYWORDS:
Entry Step,
Step, Step
Cradle,
Cradle

ISSUE DATE:
March 2008

The purpose of this Bulletin is to inform all Fleetwood dealers about the procedure to reinforce the entry step cradle on certain 2008 Fiesta and Terra motor homes.

Note: Read this entire document before starting repairs.

CONDITION:

The entry step attachment cradle on certain 2008 Fiesta and Terra motor homes may bend as a result of step usage and insufficient structural material strength.

CORRECTION:

Follow the procedures below to reinforce the entry step attachment cradle.

1. Park the motor home on a dry, level, paved surface. Put the transmission into Park and engage the parking brake.
2. Turn off the ignition and remove the ignition key. Maintain control of the ignition key until repairs are completed. This will prevent a third party from activating the ignition or motor home chassis systems.
3. Open the motor home entry door and screen door. Secure the doors in the open position with the entry door holder on the sidewall of the motor home.

⚠ WARNING

THE ENTRY STEP MAY ACTIVATE AND CYCLE WITHOUT WARNING WHILE CONNECTED TO ELECTRICAL POWER. DO NOT WORK ON AREAS OF THE ENTRY STEP THAT MAY PINCH UNTIL ELECTRICAL POWER HAS BEEN DISCONNECTED.

4. Working underneath the motor home at the entry step, unplug the electrical connector for the entry step motor.
5. Remove the four entry step mounting bolts, nuts, and washers, and carefully lower the entry step frame. Discard the original attachment hardware.

NOTE: Due to wire length on some motor homes, it may be necessary to disconnect the electrical connector for the entry step control module and remove one end of the green ground wire.

6. Locate the aluminum angle, attached to the outboard channel (nearest the motor home sidewall) of the entry step cradle, and secured with #12 tek screws. Remove or break-off these screws on the inside of the channel and dispose of debris. This will provide the space necessary to install the square tube steel reinforcement later in this procedure.

© 2008 Fleetwood Enterprises, Inc.

This bulletin is supplied for technical information only and is not an authorization for repairs.

Federal law (section 154 of the national traffic and motor vehicle safety act of 1966) requires that: If you have received a notice of recall or failure to comply from Fleetwood or any component Manufacturer, you must repair or otherwise correct the defects on vehicles remaining in your inventory, according to the notification, before selling or leasing the vehicles. Any vehicle lessor receiving this recall notice must forward a copy of the notice to the lessee within ten days.

"It is impossible to know, evaluate and advise the service trade of all conceivable ways in which service might be done or of the possible hazardous consequences of each way. Accordingly, anyone who uses a service procedure or tool must first assure that neither personal safety nor vehicle safety will be jeopardized by the selected service methods."

7. Use an electric drill with a 3/8" twist drill bit, to drill out the threads of the four weld nuts in the entry step cradle that were used to secure the entry step frame. See Figure 1.

8. Place a new 1-1/4" square steel tube inside the top of each of the two step cradle channels with the two 7/8" holes placed down over the top of the existing weld nuts. See Figure 1.

9. Place a split lock washer on each of two 3/8-16 X 2-1/2" bolts. Insert the bolts up through the inboard mounting holes for the entry step frame, through the inboard entry step cradle, and through the new 1-1/4" square steel tube. See Figure 1.

10. Place a flat washer on to each bolt inserted through the materials in Step 9 and then thread 3/8-16 locking nuts onto the bolts. Do not tighten at this time.

11. Repeat Steps 9-10 for the outboard mounting holes for the entry step frame.

12. Torque all four entry step mounting bolts to 25-30 ft-lbs.

13. Measure and mark 1-3/8" from each end of the inboard entry step cradle channel. See Figure 2.

14. Drill a 3/8" hole through the entry step cradle channel continuing up through the new 1-1/4" square steel tube on each end of the inboard entry step cradle channel. See Figures 1 and 2.

15. Place a flat washer on each of two 3/8-16 X 2-1/2" bolts. Install bolts passing up from the bottom of the entry step cradle and through each of the two holes drilled in Step 14. See Figure 1.

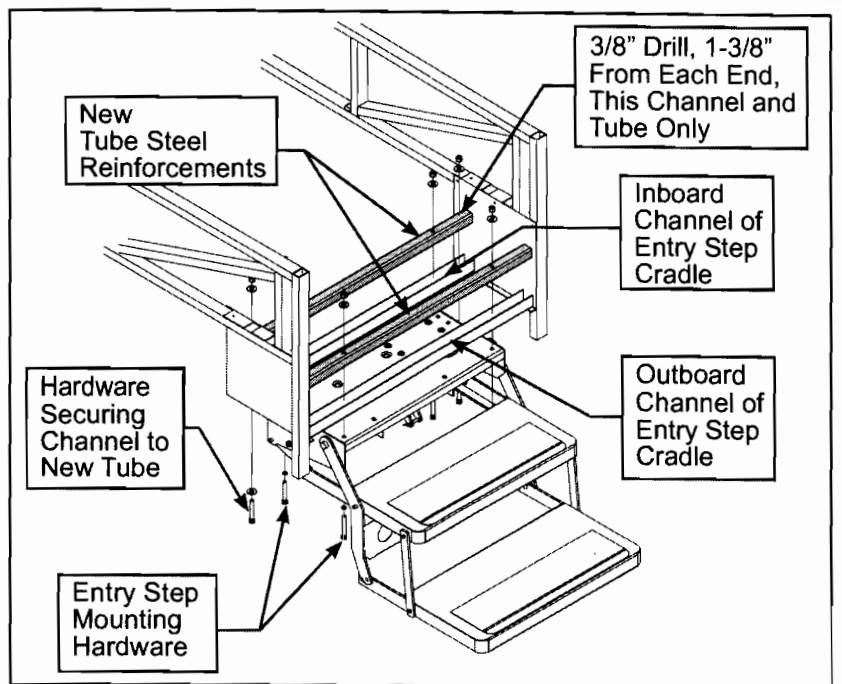

Figure 1

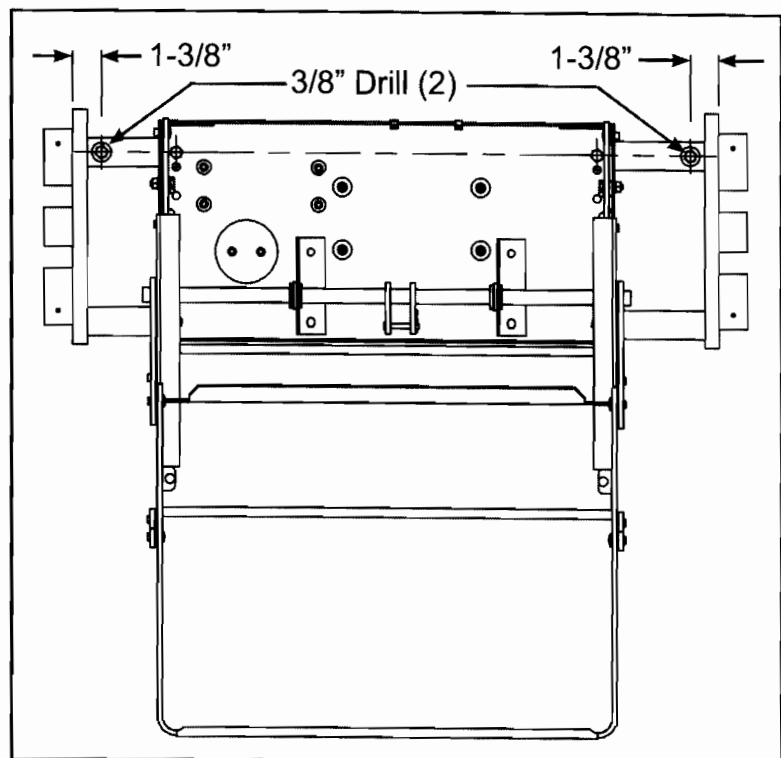

Figure 2

This bulletin is supplied for technical information only and is not an authorization for repairs.

Federal law (section 154 of the national traffic and motor vehicle safety act of 1966) requires that: If you have received a notice of recall or failure to comply from Fleetwood or any component Manufacturer, you must repair or otherwise correct the defects on vehicles remaining in your inventory, according to the notification, before selling or leasing the vehicles. Any vehicle lessor receiving this recall notice must forward a copy of the notice to the lessee within ten days.

"It is impossible to know, evaluate and advise the service trade of all conceivable ways in which service might be done or of the possible hazardous consequences of each way. Accordingly, anyone who uses a service procedure or tool must first assure that neither personal safety nor vehicle safety will be jeopardized by the selected service methods"

16. Place a flat washer on the top of each of the two bolts installed in Step 16 and then install a 3/8-16 locking nut on each. Torque these two bolts to 25-30 ft-lbs.
17. Reconnect the electrical connector for the entry step control module and the green ground wire if they were disconnected earlier.
18. Reconnect the electrical connector for the entry step motor.
19. Close and then reopen the entry door to verify proper step operation. Correct as necessary.

TOOLS:

9/16" Deep Socket, with Ratchet Handle	9/16" Combination Wrench
Electric Drill	3/8" Twist Drill Bit
Power Driver with 1/4" Hex Bit	Tape Measure
Hammer	Center Punch
Torque Wrench Capable of measuring 30 ft-lbs.	Heavy Duty Pliers

PARTS:

Part No.	Description	Qty.
550224	Entry Step Reinforcement Kit	1
	<u>Kit Contains:</u>	
	Tube Steel, Square, 1-1/4" X 11 Ga. 33-3/8" long	2
	Bolt, 3/8-16 X 2-1/2" HH Pltd	6
	Nut, 3/8-16, HH Locking, Pltd	6
	Washer, 3/8" USS Flat Pltd	8
	Washer, 3/8" Med Split Locking Pltd	4

WARRANTY LABOR ALLOWANCE:

Use the Flat Rate Codes Below for the Entry Step Reinforcement:

9200 - 11	0.1 hr.	Inspected/Not Defective
9200 - 12	1.0 hr.	Inspected/Defective/Repaired
9200 - 17	0.1 hr.	Customer Unreachable

Contact Fleetwood's Dealer Technical Support Group for questions regarding this Bulletin at:
1-800-816-9825

Fleetwood Service Literature can be accessed at: <http://www.fleetwoodrvdealers.com>

This bulletin is supplied for technical information only and is not an authorization for repairs.

Federal law (section 154 of the national traffic and motor vehicle safety act of 1966) requires that: If you have received a notice of recall or failure to comply from Fleetwood or any component Manufacturer, you must repair or otherwise correct the defects on vehicles remaining in your inventory, according to the notification, before selling or leasing the vehicles. Any vehicle lessor receiving this recall notice must forward a copy of the notice to the lessee within ten days.

"It is impossible to know, evaluate and advise the service trade of all conceivable ways in which service might be done or of the possible hazardous consequences of each way. Accordingly, anyone who uses a service procedure or tool must first assure that neither personal safety nor vehicle safety will be jeopardized by the selected service methods."

Recall Bulletin 80211 - Affected Motor Home Serial Numbers

2008 Fiesta

794L84799201
794B84799202
794L84799296
794L84799297
794L84799298
794L84799299
794B84799317

794B84799318
794B84799320
794B87172712
794B87172819
794B87172820
794B87172821
794L87172835

794L87172836
794T87172862
794B87172889
794B87172891
794B87172892
794B87172893
794L87172981

794L87172982
794L87172983
794L87172988
794L87172992
794B87172994
794B87172997

Recall Bulletin 80211 - Affected Motor Home Serial Numbers

2008 Terra

793L84799199
793B84799200
793L84799305
793L84799306
793L84799308
793L84799309

793B84799310
793B84799311
793B84799312
793L87172711
793B87172807
793B87172808

793L87172940
793B87172941
793B87172942
793B87172944
793B87172945
793L87172946

793L87172947
793L87172948
793B87172966
793B87172968
793B87172969

This bulletin is supplied for technical information only and is not an authorization for repairs.

Federal law (section 154 of the national traffic and motor vehicle safety act of 1966) requires that: if you have received a notice of recall or failure to comply from Fleetwood or any component Manufacturer, you must repair or otherwise correct the defects on vehicles remaining in your inventory, according to the notification, before selling or leasing the vehicles. Any vehicle lessor receiving this recall notice must forward a copy of the notice to the lessee within ten days.

"It is impossible to know, evaluate and advise the service trade of all conceivable ways in which service might be done or of the possible hazardous consequences of each way. Accordingly, anyone who uses a service procedure or tool must first assure that neither personal safety nor vehicle safety will be jeopardized by the selected service methods."



Fleetwood Enterprises, Inc.
3030 Myers Street / Riverside, CA 92503-5527
P.O. Box 7638 / Riverside, CA 92513-7638
p: 800.322.8216 / www.fleetwoodrv.com

IMPORTANT RECALL INFORMATION #80211

March, 2008

Dear Valued Fleetwood Motor Home Customer:

This notice is sent to you in accordance with the requirements of the National Traffic and Motor Vehicle Safety Act.

Fleetwood Enterprises, Inc., on behalf of its subsidiary manufacturing centers located in Riverside, California and Paxinos, Pennsylvania has decided that a defect which relates to motor vehicle safety exists in certain 2008 model year Fiesta and Terra model motor homes.

WHAT IS THE PROBLEM?

On certain 2008 Fiesta and Terra model motor homes affected by this recall, the entry step attachment cradle/support may bend as a result of step usage and insufficient structural material strength, possible resulting in risk of personal injury, vehicle and/or other property damage.

WHAT SHOULD YOU DO?

Please make certain your motor home is inspected and repaired by contacting your selling dealer, and making an appointment to have this inspection and repair performed. If they are not available, another Fleetwood motor home dealer may do this work for you.

WHAT WILL FLEETWOOD DO?

With your continued satisfaction in mind, it is our intention to have these repairs made at your convenience with as little disruption as possible. Effective immediately, Fleetwood dealers will be supplied with all the information needed to enable them to inspect and if necessary, reinforce the entry step attachment cradle/support.

The total length of time your motor home will be out of service will depend on the dealer's work schedule.

If you have had this concern corrected previously, you may be eligible for reimbursement of your cost for that repair. For more information regarding this recall #80211, contact Fleetwood Owner Relations at 800-509-3418.

When you deliver your motor home for repairs, your dealer will complete a Fleetwood Repair Order. Upon completion of the repair, please sign the dealership's Repair Order or Fleetwood's Repair Order and fill out the enclosed self-addressed **Vehicle Information Update Card** and return it to Fleetwood. This will allow us to update our records and if necessary, notify the new owner using the information you provide.

For leased vehicles: Federal regulation requires that any vehicle lessor receiving this recall notice must forward a copy of this notice to the lessee within ten days.

If you are unable to obtain the specified repair promptly and without charge, please contact:

FLEETWOOD OWNER RELATIONS - RECALL #80211

P.O. Box 1007
Decatur, Indiana 46733
(800) 509-3418

If you believe that the dealer and Fleetwood Enterprises, Inc., have failed or have been unable to remedy the defect without charge or within a reasonable period of time, you may submit a complaint to:

Administrator
National Highway Traffic Safety Administration
1200 New Jersey Avenue, SE
Washington, DC 20590

Or call the toll-free Vehicle Safety Hotline at 1-888-327-4236 (TTY: 1-800-424-9153); or go to
<http://www.safercar.gov>

Fleetwood Enterprises, Inc., is taking these steps in the interest of your safety. We regret any inconvenience this may cause you.

Sincerely,

FLEETWOOD ENTERPRISES, INC.



Tina Inkrote
Service Administrator
Motor Home Division