

VOLKSWAGEN

GROUP OF AMERICA

MARIA COTTER NAME
LEAD CAMPAIGN ADMINISTRATOR TITLE
PRODUCT COMPLIANCE DEPARTMENT
248-754-5000 PHONE
248-754-5093 FAX
JANUARY 29, 2009 DATE

Ms. Delia Lopez
Recall Analyst for Safety Assurance
National Highway Traffic Safety Administration
Attn: Recall Management Division (NVS-215)
U.S. Department of Transportation
1200 New Jersey Avenue, S.E.
Washington, DC 20590

VOLKSWAGEN GROUP OF AMERICA, INC.
3800 HAMLIN ROAD
AUBURN HILLS, MI 48326
PHONE +1 248 754 5000

**Subject: Revised Documents for Recall Campaigns 08V-157 (20L8/JY),
08V-064 (70D1/JX) and 07V-375 (JL00/JL)**

Dear Ms. Lopez:

Pursuant to the requirements set forth in Part 573.6 of Title 49 of the Code of Federal Regulations, we are submitting three (3) copies of the following revised communications for recall campaigns 08V-157 (20L8/JY), 08V-064 (70D1/JX) and 07V-375 (JL00/JL):

- Dealer notification letter
- Work Procedure and Claiming Instructions

If you have any questions or require additional information, please contact me.

Sincerely,



Maria Cotter
Volkswagen Group of America, Inc.
Lead Campaign Administrator
Product Compliance -Service and Quality
Enclosures

Audi of America, Inc.



SAFETY RECALL INFORMATION

Audi of America, Inc.
3800 Hamlin Road
Auburn Hills, MI 48326
United States of America
www.audiusa.com

January 2009

**Subject: Revision to Safety Recalls 20L8/JY, 70D1/JX and JL00/JL
SAGA claim coding instructions**

Dear Service Manager and Warranty Administrator:

This letter is to inform you that the following Safety Recalls have been revised:

20L8/JY – Reinforce Fuel Tank Rollover Valve Nipple

70D1/JX – Replace C-pillar trim cover clip

JL00/JL – Fuel pump replacement

These three Safety Recalls now require the **part number in the material field** to be selected as the causal indicator when entering a claim in SAGA. Please refer to the applicable campaign circular for further details.

Sincerely,

Audi Product Quality and Technical Service

IMPORTANT INFORMATION

Please inform and provide a copy of this document to every person in your dealership with campaign-related responsibilities, including Service, Parts and Accounting personnel. By law, dealers must correct, prior to delivery for sale or lease, any vehicle that fails to comply with an applicable Federal Motor Vehicle Safety Standard or that contains a defect relating to motor vehicle safety. If you have questions regarding this or any other campaign, please call (800) 741-2919.



Safety Recall Circular

Code: **JX/70D1**

**Subject: 2008 MY Audi TT Coupe
Replace C-Pillar Trim Cover Clip**

REVISION

January 2009

Revision Summary

Added Causal Indicator to SAGA Claim Entry Procedure chart.

Problem Description

Audi has decided that certain model year 2008 Audi TT Coupe vehicles were produced with C-pillar trim cover clips that do not provide adequate retention. In the event of a deployment of the rear pyrotechnic safety belt, the C-pillar trim cover may become detached from the sheet metal due to low retention force of the trim clip. The detached trim cover could pose a risk of personal injury for vehicle front seat occupants.

Corrective Action

Install a new clip on the C-pillar trim cover.

VIN Range and Production Date of Affected Vehicles

2008 TT Coupe (USA including PRI)

TRU__8J_81000166 – TRU__8J_81001178

2008 TT Coupe (CANADA)

TRU__8J_81000354 – TRU__8J_81001026

Production Date: January 2007 - February 2007

NOTE: Check ElsaWeb on the day of repair to verify vehicle eligibility and attach the screen print to the repair order. This is the only valid campaign inquiry and verification source. Some vehicles may be involved in an additional action(s); any additional work can be done while the vehicle is in for this action.

Allocation Report of Affected Vehicles

In the Service Manager's Package, dealers with affected vehicles received a report containing the complete VIN with customer name and address data. Dealers did not receive a report if they had no affected vehicles.

NOTE: The allocation report contains owner names and addresses obtained from Motor Vehicle Registration Records. By law, this data may only be used for recall purposes. Use for any other reason may be a violation of law in many states/provinces. Accordingly, you are urged to limit the use of this report.

Parts Information and Allocation

On or about March 5, 2008 you received an allocation of parts. If you have exhausted your allocated

parts for vehicles affected by this safety recall, but have exceeded your Upper Order Limit, please submit your requests for additional material via email to upperorderlimits@audi.com.

Owner Notification Mailing

On or about March 7, 2008 Audi began customer notification to all known owners of affected vehicles. A sample copy of this letter is enclosed.

Claim Entry Procedure

Immediately upon completion of the repair work, enter the Repair Operation(s) from the chart below and the **Applicable Criteria ID that is shown in ElsaWeb**. Claims will only be paid for vehicles that show this campaign open in ElsaWeb on the day of the repair. To help ensure prompt and proper payment, attach the screen print to the repair order.

SAGA Claim Entry Procedure

Service No.: 70D1
Damage Code: 0099
Parts Manufacturer - Removed part: 002
Causal indicator - Select Clip (8P0 867 276 B) as Causal Part. **NEW**

Claim Type

Sold vehicle = 7 10
Unsold vehicle = 7 90

Criterion Code	Repair Operation	Damage Code	Time Units
----------------	------------------	-------------	------------

8J	Install new clip	70 68 56 99	60 TU
----	------------------	-------------	-------

There is NO reimbursement for Vehicle Wash or Loaner Vehicle

Quantity	Designation	Part Number
----------	-------------	-------------

2	Clip	8P0 867 276 B
---	------	---------------

If Customer Refuses Repairs:

Fax the Repair Order to VWoA at (248) 754-5093 and provide VIN, applicable Service Number, Customer Information, Dealer Number, and Date.

The information in this document is intended for use only by skilled technicians who have the proper tools, equipment and training to correctly and safely maintain your vehicle. These procedures are not intended to be attempted by "do-it-yourselfers," and you should not assume this document applies to your vehicle, or that your vehicle has the condition described. To determine whether this information applies, contact an authorized Audi dealer. ©2009 Audi of America, LLC and Audi Canada. All Rights Reserved.

Customer Letter Example (United States)

March 2008

**Subject: Safety Recall JX / 70D1
2008 Model Year Audi TT Coupe
Replace C-Pillar Trim Cover Clip**

Dear Audi Owner:

This notice is sent to you in accordance with the requirements of the National Traffic and Motor Vehicle Safety Act. Audi has decided that a defect, which relates to motor vehicle safety, exists in some 2008 model year Audi TT Coupe vehicles. Our records show that you are the owner of one of these vehicles.

What is the issue?

Certain MY 2008 Audi TT Coupe vehicles were produced with C-pillar trim cover clips that do not provide adequate retention. In the event of a deployment of the rear pyrotechnic safety belt, the C-pillar trim cover may become detached from the sheet metal due to low retention force of the trim clip. The detached trim cover could pose a risk of personal injury for vehicle front seat occupants.

What Will Audi Do?

In order to prevent the conditions described above, we will replace the clip holding the front of the C-Pillar trim cover on affected vehicles.

What We Would Like You to Do

Please contact your authorized Audi dealer and arrange for an appointment without delay. This service will take less than one hour and will be free of charge. Please keep in mind that your dealer may need additional time for the preparation of the repair, as well as to accommodate their daily workshop schedule.

Lease Vehicles

If you are the lessor and registered owner of the vehicle identified in this letter, please forward this information via first class mail to the lessee.

Have You Changed Your Address Or Sold The Vehicle?

If you have, please fill out the enclosed prepaid Owner Reply card and mail it to us so we can update our records.

Reimbursement of Expenses

If you have previously paid for replacement of the C-pillar trim cover, the enclosed form explains how to request reimbursement.

Service Help From Us

If your authorized Audi dealer fails or is unable to complete this work free of charge within a reasonable amount of time, please call or write to:

*Audi of America, Inc.
Attn: Customer Relations (JX / 70D1)
3499 West Hamlin Road
Rochester Hills, MI 48309
1-800-253-2834*

If you still cannot obtain satisfaction, you may file a complaint with: Administrator, National Highway Traffic Safety Administration, 1200 New Jersey Avenue S.E., Washington, DC 20590; or call the toll-free Vehicle Safety Hotline at 1-888-327-4236 (TTY: 1-800-424-9153), or go to <http://www.safercar.gov/>.

We regret any inconvenience this matter may cause. Thank you for your continued loyalty!

Audi Product Compliance

The information in this document is intended for use only by skilled technicians who have the proper tools, equipment and training to correctly and safely maintain your vehicle. These procedures are not intended to be attempted by "do-it-yourselfers," and you should not assume this document applies to your vehicle, or that your vehicle has the condition described. To determine whether this information applies, contact an authorized Audi dealer. ©2009 Audi of America, LLC and Audi Canada. All Rights Reserved.

Customer Letter Example (Canada)

March 2008

**Subject: Safety Recall JX / 70D1
2008 Model Year Audi TT Coupe
Replace C-Pillar Trim Cover Clip**

Dear Audi Owner:

This notice is sent to you in accordance with the requirements of the Canadian Motor Vehicle Safety Act. Audi has decided that a defect, which relates to motor vehicle safety, exists in some 2008 model year Audi TT Coupe vehicles. Our records show that you are the owner of one of these vehicles.

What is the issue?

Certain MY 2008 Audi TT Coupe vehicles were produced with C-pillar trim cover clips that do not provide adequate retention. In the event of a deployment of the rear pyrotechnic safety belt, the C-pillar trim cover may become detached from the sheet metal due to low retention force of the trim clip. The detached trim cover could pose a risk of personal injury for vehicle front seat occupants.

What Will Audi Do?

In order to prevent the conditions described above, we will replace the clip holding the front of the C-Pillar trim cover on affected vehicles.

What We Would Like You to Do

Please contact your authorized Audi dealer and arrange for an appointment without delay. This service will take less than one hour and will be free of charge. Please keep in mind that your dealer may need additional time for the preparation of the repair, as well as to accommodate their daily workshop schedule.

Lease Vehicles

If you are the lessor and registered owner of the vehicle identified in this letter, please forward this information via first class mail to the lessee.

Have You Changed Your Address Or Sold The Vehicle?

If you have, please fill out the enclosed prepaid Owner Reply card and mail it to us so we can update our records.

Reimbursement of Expenses

If you have previously paid for replacement of the C-pillar trim cover, the enclosed form explains how to request reimbursement.

Service Help From Us

If your authorized Audi dealer fails or is unable to complete this work free of charge within a reasonable amount of time, please call or write to:

*Audi Canada
Attn: Customer Relations (JX / 70D1)
P.O. Box 842, Str. A
Windsor, ON N9A 9Z9
1-800-253-2834*

We look forward to providing this service for you. Thank you for your continued loyalty!

Audi Product Compliance

The information in this document is intended for use only by skilled technicians who have the proper tools, equipment and training to correctly and safely maintain your vehicle. These procedures are not intended to be attempted by "do-it-yourselfers," and you should not assume this document applies to your vehicle, or that your vehicle has the condition described. To determine whether this information applies, contact an authorized Audi dealer. ©2009 Audi of America, LLC and Audi Canada. All Rights Reserved.

Parts:

<u>Quantity</u>	<u>Part Number</u>	<u>Part Name</u>
2	8P0 867 276 B	Retaining clip

Special Tools:

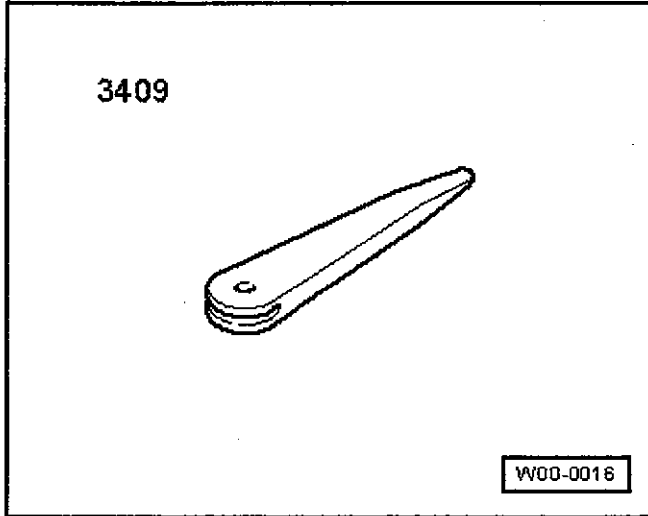

← Trim Removal Wedge -3409-

Section A – Remove C-Pillar trim

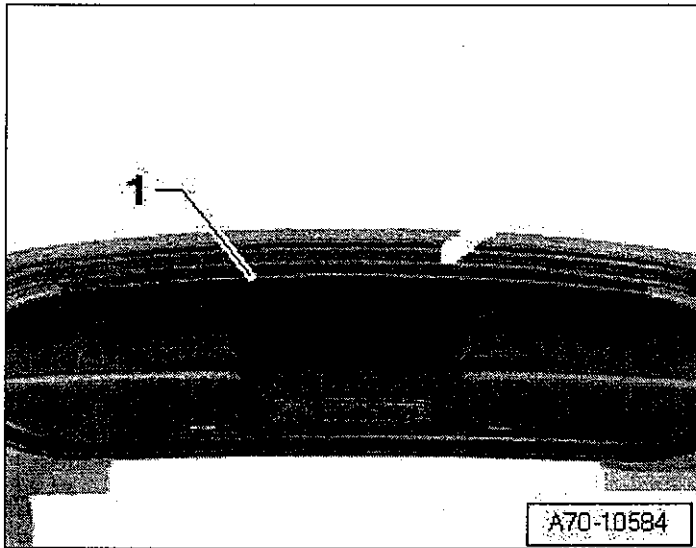

Note:

To prevent damage, ensure vehicle interior is at room temperature before removing trim panels

- Open rear hatch
 - Fold front seat backrests forward and move front seats as far forward as possible to gain access to rear seat
- ← Unclip roof panel trim -1- with Trim Removal Wedge -3409-

The information in this document is intended for use only by skilled technicians who have the proper tools, equipment and training to correctly and safely maintain your vehicle. These procedures are not intended to be attempted by "do-it-yourselfers," and you should not assume this document applies to your vehicle, or that your vehicle has the condition described. To determine whether this information applies, contact an authorized Audi dealer. ©2009 Audi of America, LLC and Audi Canada. All Rights Reserved.

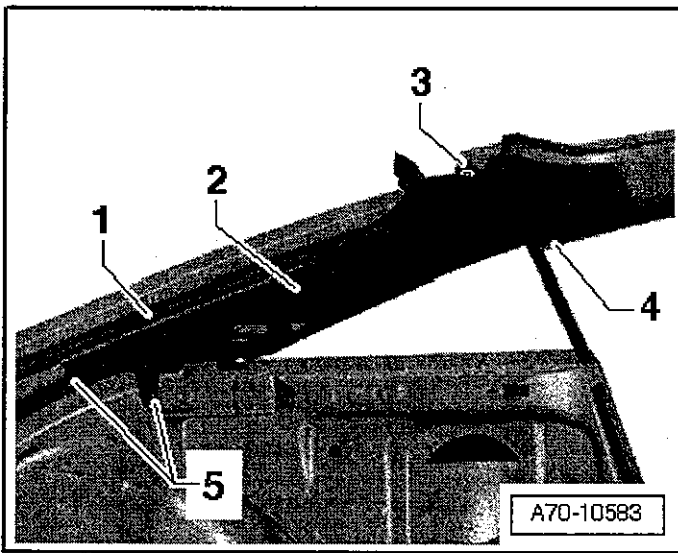

- ⇐ Remove expanding clip -3- on right side C-pillar trim
- Repeat removal of expanding clip -3- on left side C-pillar trim -2-

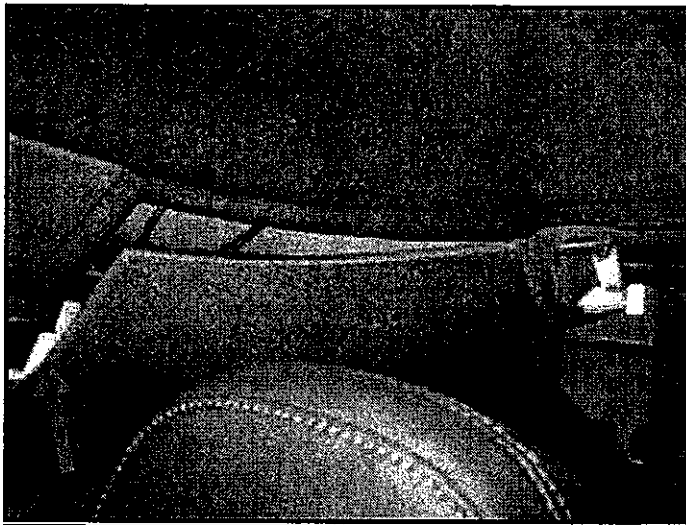

- ⇐ Using Trim Removal Wedge -3409- detach right side C-pillar trim and pull downward at front of trim -arrow-
- Repeat detachment of left side C-pillar trim

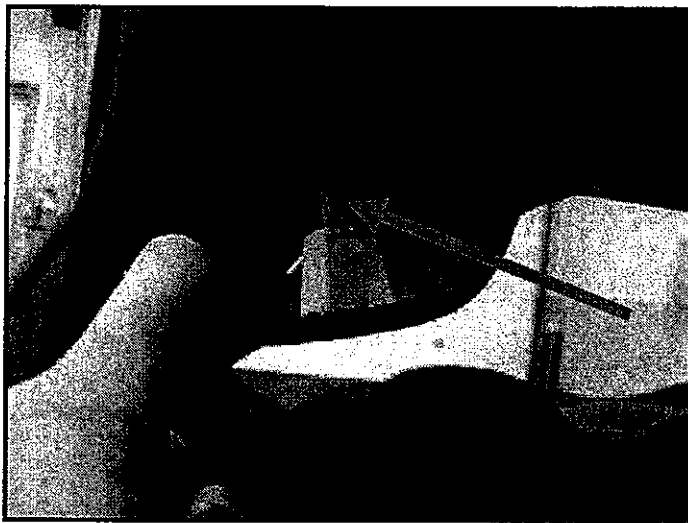

- ⇐ Remove clip at front of right side C-pillar trim and discard. Install new clip (8P0 867 276 B) on right side C-pillar trim
- Repeat removal of clip on left side C-pillar trim

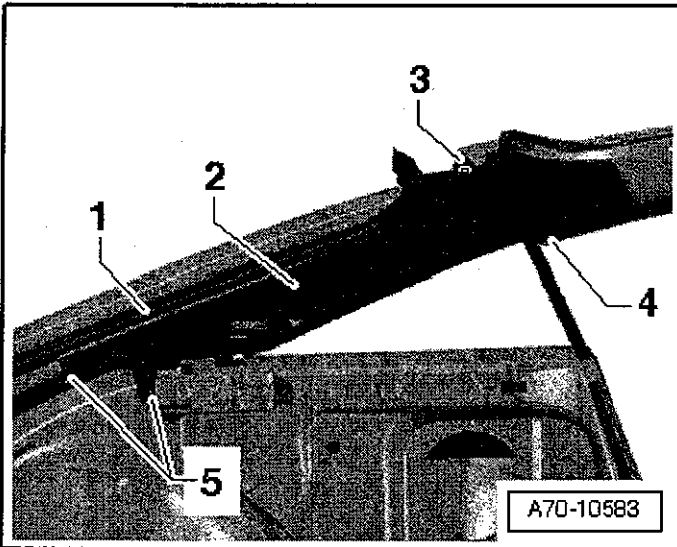

- ← Reinstall expansion clip -3- into right side C-pillar trim
- Repeat installation of expansion clip -3- into left side C-pillar trim

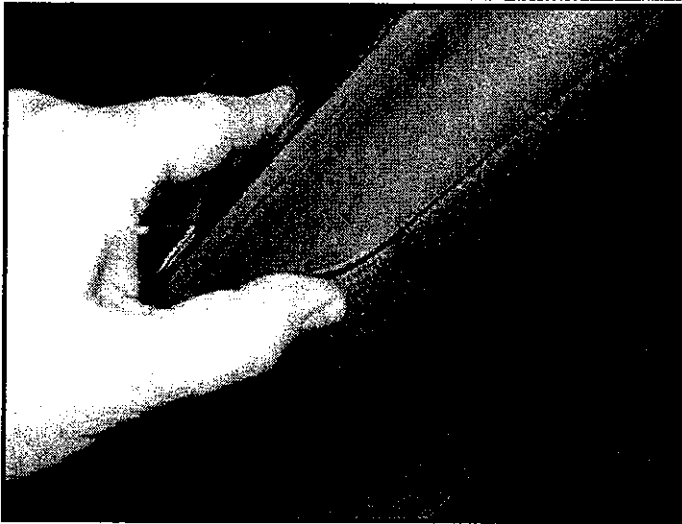

- ← Reinstall right side C-pillar trim. Restore door seal position after trim is reinstalled
- Repeat installation of left side C-pillar trim and ensure door seal position after trim is installed



Note:

If door seals are not installed properly water leaks may occur

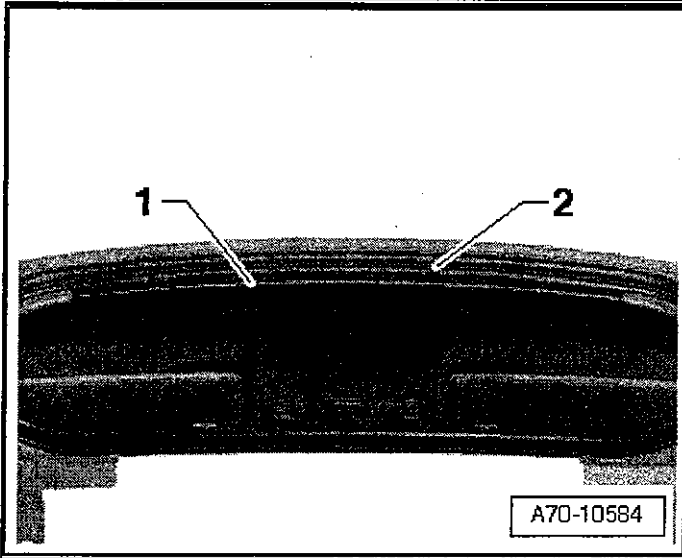

- ← Install roof panel -1- into roof of vehicle
- Stretch rear lid seal lip -2- over roof panel trim -1-



Note:

If rear hatch seal is not installed properly water leaks may occur

- Destroy and properly dispose of removed parts in accordance with local, state and federal/provincial environmental regulations.

WORK IS COMPLETE

The information in this document is intended for use only by skilled technicians who have the proper tools, equipment and training to correctly and safely maintain your vehicle. These procedures are not intended to be attempted by "do-it-yourselfers," and you should not assume this document applies to your vehicle, or that your vehicle has the condition described. To determine whether this information applies, contact an authorized Audi dealer. ©2009 Audi of America, LLC and Audi Canada. All Rights Reserved.