

NEWMAR CORPORATION WARRANTY DEPARTMENT

TECHNICAL SERVICE BULLETIN							
DATE ISSUED	MODEL YEAR(S) AFFECTED		MODEL(S) AFFECTED			TSB #	
3/31/08	2007-2008		All DP on Freightliner Chassis			329	
BRAND						TYPE	
All	<input type="checkbox"/>	American Star	<input type="checkbox"/>	Mountain Aire	<input type="checkbox"/>	All	<input type="checkbox"/> TT <input type="checkbox"/>
Cypress	<input type="checkbox"/>	Dutch Star	<input checked="" type="checkbox"/>	Kountry Aire	<input type="checkbox"/>	FW	<input type="checkbox"/> CA <input type="checkbox"/>
Northern Star	<input type="checkbox"/>	Kountry Star	<input checked="" type="checkbox"/>	Essex	<input type="checkbox"/>	DP	<input type="checkbox"/> DB <input type="checkbox"/>
Scottsdale	<input type="checkbox"/>	King Aire	<input type="checkbox"/>	London Aire	<input type="checkbox"/>		
All Star ME	<input type="checkbox"/>	Ventana	<input checked="" type="checkbox"/>				
<input type="checkbox"/> Air Conditioning & Heating <input type="checkbox"/> Appliances & Accessories <input type="checkbox"/> Cabinets & Furniture <input checked="" type="checkbox"/> Chassis Components <input type="checkbox"/> Construction Components				<input type="checkbox"/> Electrical Components <input type="checkbox"/> Exterior Components <input type="checkbox"/> Interior Components <input type="checkbox"/> Plumbing & Bath Components <input type="checkbox"/> Windows, Awnings, Vents, & Doors			
DESCRIPTION OF PROBLEM							
Freightliner has released NHTSA Recall 07V343 regarding the potential failure of steering gear recirculating ball causing loss of steering control.							
RECOMMENDED SOLUTION							
Inspect steering system per Freightliners attached direction. READ ALL DIRECTIONS PRIOR TO PERFORMING THE REQUIRED INSPECTION, OR BEFORE ATTEMPTING ANY REPAIRS. Any questions should be directed to Freightliner at 1-800-547-0712. Repairs should be billed through Freightliner.							

If you have any questions regarding this T.S.B., please contact a Warranty Service Representative at Newmar Corporation.

Recall Campaign

January 2008
FL509A-C
NHTSA #07V-343

Work Instructions

Subject: ZF Lenksysteme 8018 Steering Gears

Models Affected: Specific Freightliner Custom Chassis VCL, XB, and XC motorhome chassis manufactured between June 13, 2002, and June 13, 2007, with certain independent front suspension assemblies with ZF Lenksysteme 8018 steering gears.

NOTE: FL509 is being released in phases – FL509A (1,500 vehicles) will be released first with FL509B (approximately 1,000 to 1,500 vehicles) and FL509C (the remaining vehicles) following at later dates. Please perform the Recall when ServicePro shows it is open for the specific vehicle.

Manufacturing Date Code Inspection

1. Check the base label (Form WAR259) for a completion sticker for FL509 (Form WAR280) indicating this work has been done. The base label is usually located on the front wall under the dash in motorhomes. If a sticker for FL509 is present, nothing further needs to be done. If a sticker is not present, go to the next step.
2. Shut down the engine, set the parking brake, and chock the tires.
3. Check the date code on the data plate of the steering gear. See Fig. 1.
 - 3.1 If the date code is 250407 or more, nothing further needs to be done. Go to step 4.
 - 3.2 If the date code is less than 250407 go to "Steering Gear Replacement."
4. Clean a spot on the base label, write the Recall number, FL509, on a blank completion sticker, and attach it to the base label.
5. Remove the chocks from tires.

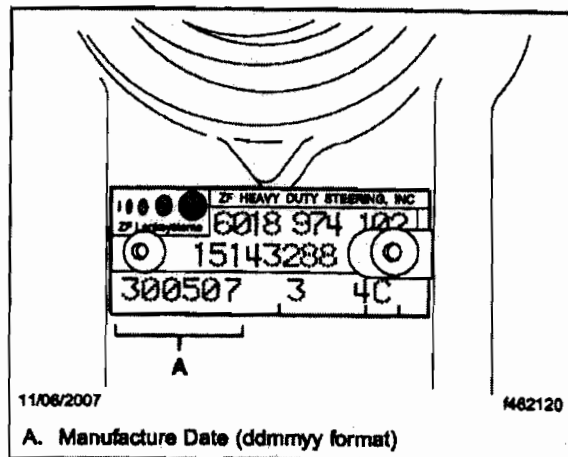

Fig. 1, Data Plate Identification

Steering Gear Replacement

1. Raise and support the vehicle so there is 12 inches (30 cm) clearance from the ground. Position jack stands under the frame rails to support the vehicle.
2. Remove the tie-rods.
 - 2.1 Remove the cotter pins and loosen the tie-rod end retaining nuts on the left and right sides. Leave the nut loosely attached.

IMPORTANT: Do not use a pry-bar or pickle fork to remove the tie-rod end, this will damage the seal and require replacement.

 - 2.2 Use a two-arm gear puller to press the tie-rod end ball stud out of the steering arm taper. Disconnect and set the tie rod end aside.
3. Bleed the steering gear according to shop practice. Mark and disconnect the pressure and return hoses from the steering gear.
4. Disconnect the intermediate shaft.
 - 4.1 Remove the pinch bolt from the U-joint of the intermediate shaft.
 - 4.2 Spread the joint slightly by using a screwdriver, tap, or punch in the slot to increase the gap.
 - 4.3 Slide the U-joint forward and out of the way.

NOTE: The pitman arm must be removed assembled to the steering gear output shaft. It is optional to leave the tie-rods attached to the pitman arm and remove the entire assembly at one time. You may also remove the inner tie-rod end from the pitman arm at this time via the two-arm gear puller used for the outer tie-rod ends.

5. Remove the steering gear.
 - 5.1 Using a 1-3/16 impact socket, loosen the four mounting bolts. See Fig. 2.

IMPORTANT: Use two assistants while performing the following procedures.

- 5.2 Remove three nuts, leaving the centermost assembled in order to prevent the steering gear from falling.
- 5.3 Position 1 x 4 boards (as needed) across the lower control arms, and use a transmission jack to support and receive the gear when it's disconnected. Remove the last nut, lower the gear, and remove to one side.

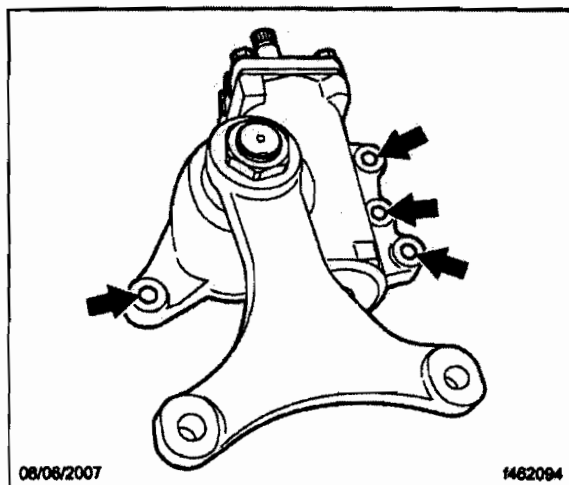

Fig. 2, Steering Gear Mounting Bolts

Recall Campaign

FREIGHTLINER
LLC
A DaimlerChrysler Company

January 2008
FL509A-C
NHTSA #07V-343

6. Install the new steering gear.

IMPORTANT: Use two assistants while performing the following procedure.

- 6.1 Position the new steering gear and pitman arm below its assembled position.
 - 6.2 Using a transmission jack, lift the gear into place, piloting on the mounting bolts, then quickly thread at least one nut into place to prevent the gear from falling.
 - 6.3 Install all remaining nuts, then tighten all four nuts 378 to 462 lbf-ft (18 to 22 N-m).
 - 6.4 Connect the pressure and return hoses to the steering gear.
7. Connect the intermediate shaft.
- 7.1 Slide the intermediate shaft U-joint onto the steering gear input shaft.
 - 7.2 Install a new pinch bolt in the U-joint, then install a new locknut on the pinch bolt and tighten the locknut 55 to 65 lbf-ft (75 to 88 N-m).
 - 7.3 Apply white Torque Seal F-900 to the exposed pinch-bolt thread and to the locknut.
8. Install the tie-rod.
- 8.1 Insert the tie-rod end ball into the steer arm taper. Connect the tie-rod end.
IMPORTANT: Before tightening tie-rod end fasteners, coat the tie-rod end ball with 15/40 oil.
 - 8.2 Tighten the outer tie-rod retaining nuts on the left and right sides. Tighten to 184 lbf-ft (250 N-m).
 - 8.3 Install the cotter pins
- NOTE:** Poppets are preset, there is no poppet valve adjustment needed.
9. Clean a spot on the base label and attach a completion sticker for Recall FL509.
 10. Remove the chocks from the tires.