



April 30, 2008

Ms. Kathy DeMeter, Director
Office of Defects Investigation
U.S. Department of Transportation
National Highway Traffic Safety Admin.
400 - 7th Street S.W.
Washington, DC 20590

RECEIVED
2008 MAY 19 - 10:30 AM
OFFICE OF RECALL
MANAGEMENT DIVISION

08V-226
(14 Pages)

Dear Ms. DeMeter:

Winnebago Industries[®] submits the following report pursuant to Part 573 of the NHTSA regulations. The numbered paragraphs below correspond to those found at Part 573.5(c).

1. Winnebago Industries, Inc.
P.O. Box 152
Forest City, IA 50436
2. The motor vehicles potentially containing the defective component are: Certain 2007 through 2008 Winnebago[®] models Journey, Destination, Tour and Itasca[®] models Meridian, Latitude, Ellipse motor homes. These motor homes were built between February 2007 through August 2007. The vehicles are being identified using the model number and production records showing VINs.
3. The total number of vehicles potentially containing the defective component is: 306.
4. The percentage of vehicles estimated to contain the defect is less than 1%.
5. The defect involves the front axle assembly, the fasteners that attach the steering arm or tie rod arms to the spindle may have been over or under tightened. Incorrectly tightened fasteners may fatigue and fracture, resulting in a possible vehicle crash without prior warning.
6. Winnebago Industries discovered the defect as a result of an April 24 e-mail from David Stanley of Freightliner LLC to Ron Post of Winnebago Industries. Referencing their recall # FL-501
7. N/A.
8. Winnebago will continue to assist Freightliner LLC to correct the situation as we provide them a current list of owners on a weekly basis. Freightliner LLC will be conducting the recall.
9. N/A.
10. N/A.
11. N/A.

0804p573

Ms. Kathy DeMeter, Director
April 29, 2008
Page Two

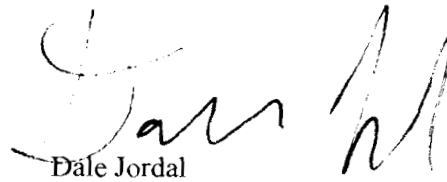

Dale Jordal
Product Safety Administrator

0804p573

Enclosure



Nasser Zamani
Manager
Compliance and Regulatory Affairs

Freightliner LLC
4747 N. Channel Ave
Portland, OR 97217-7699
503-745-6910 Phone
503-745-5544 Fax
NasserZamani@Freightliner.com

July 3, 2007

Dan Smith
Associate Administrator for Vehicle Safety
National Highway Traffic Safety Administration
1200 New Jersey Avenue S.E.
Washington, D.C. 20590

Re: Defect Information Report FL-501, AAC axle Steering Arm Bolts

Mr. Smith:

In accordance with Part 573 of Title 49 of the Code of Federal Regulations, Freightliner LLC herewith reports a safety campaign to recall approximately 18,000 Freightliner, Sterling, Western Star, Freightliner Custom Chassis, and Thomas Built Buses vehicles manufactured January 5, 2007 to May 17, 2007 with a defect in the front axle assembly.

Attached is Freightliner's Defect Information Report.

Please contact me if you have any questions.

Sincerely yours,

Nasser Zamani

Cc: Michael Mason, CAL-OSHA
Enclosure
Certified Mail#

Defect Information Report

(Section 573.6)

July 3, 2007

(c)(1) Manufacturer: Freightliner LLC
P.O. BOX 3849
Portland, Oregon 97208
(503) 745-5219

Brands: Freightliner, Sterling, Western Star, Freightliner Custom Chassis, Thomas Built Buses

(c)(2) Vehicles identification:**Model(s) affected:**

Freightliner: Columbia, Century ST, Coronado, FLD120SD, Classic, Classic XL, Business Class M2

Sterling: Acterra, A-Line, L-Line

Western Star: 4900

FCCC: B2 School Bus Chassis, van chassis, RV motorhome chassis

Thomas Built Buses: C2 Saf-T-Liner School Bus, HDX bus models

Model Years affected: 2007 to 2008

Manufacture Dates: January 5, 2007 to May 17, 2007

Basis for determining population: All models with 8,000 pound to 14, 700 pound capacity AAC front axles. Axle serial numbers provided by AAC were matched to VINs using Freightliner production records.

Component manufacturer if other than the vehicle manufacturer:

Axle Alliance Company (AAC)

Detroit Diesel (part of the Freightliner group of companies)

13400 Outer Drive West

Detroit, Michigan 48239

(c)(3) Total number of vehicles potentially affected: Approximately 18,000

(c)(4) Percentage of vehicles estimated to contain the defect: less than 1%

(c)(5) Description of the defect: During front axle assembly, the fasteners that attach the steering arm or tie rod arms to the spindle may be over or under tightened.

49CFR Section 577.5(f) Evaluation of the risk to motor vehicle safety: Incorrectly torqued steering arm fasteners may fatigue and fracture and cause a crash without warning.

(c)(6) Chronology of principal events:

In April 2007, a customer fleet driver reported an increased vibration in the steering and pulled to the side of the road. The following inspection found that the rear most attaching bolt that retains the LH tie rod end bracket was missing, and the front position bolt was cracked and ready to fall out. The same fleet had reported a similar failure earlier. The axle assembly was returned to AAC for evaluation.

AAC investigated and found the steering arm and tie rod arms may not have been tightened correctly on some axle assemblies following a production process change at the beginning of the year. AAC implemented corrective action in production at the end of April.

(c)(7) Noncompliance-test or other data: not applicable

(c)(8) Remedial program: Repairs will be performed by Freightliner dealerships and Direct Warranty customers, i.e., customers approved by Freightliner to do their own warranty repairs. The suspect fasteners will be inspected. Dealer notifications will be posted August 24, 2007.

Estimated Owner Notification Date: Customer notification will be by first class mail using Freightliner records to determine the customers affected. This will be completed approximately August 24, 2007.

Reimbursement Plan: All prior repairs, if any, would have been completed under warranty.

(c) (9) **Communications sent to dealers and owners:** Copies will be submitted as a supplemental report when available.

(c) (10) **Copy of proposed owner notification letter:** A draft will be sent for ODI review when available.

(c) (11) **Manufacturer's campaign number:** FL-501

**Daimler Trucks
North America LLC**

Daimler Trucks North America LLC
P.O. Box 4090
Portland, OR 97208-4090
800.547.0712 Phone
503.745.9009 Fax

**April 2008
FL501
NHTSA #07V-306**

**Recall Notification
Subject: AAC Front Axle Tie Rod and Steering Arm Fasteners**

Daimler Trucks North America has begun notifying its dealers and customers of a safety related defect that exists in certain chassis manufactured by Freightliner Custom Chassis Corporation and delivered to your company. A remedy without charge is now available, and owners may take their vehicle to a Daimler Trucks North America-authorized service facility to have the recall performed. The Recall Bulletin, which includes a representative copy of the owner notification and dealer work instructions, and a list of potentially affected vehicles delivered to you are attached for your information.

Your company may have an obligation to notify its dealers, distributors, and customers of this recall under Title 49 Code of Federal Regulations Part 577.13 and/or Motor Vehicle Safety Act Section 10(1).

If you have questions or need further information, please contact the Warranty Campaigns Department at (800) 547-0712, 7:00 a.m. to 4:00 p.m. Pacific Time, Monday through Friday, e-mail address WarrantyCampaigns@Freightliner.com.

WARRANTY CAMPAIGNS DEPARTMENT
Enclosure

DAIMLER

Daimler Trucks North America
Nasser Zamani
Manager
Compliance and Regulatory Affairs

March 5, 2008

Nigel Mortimer
Head of Recalls
Defect Investigations and Recalls
Transport Canada
2780 Sheffield Road
Ottawa, Ontario K1B 3V9

**Re: Supplemental Information Notice No. 1
07-229, FL-501, AAC Front Axle Steering Arm Bolts**

Mr. Mortimer

Please be advised we will forward the enclosed information to the affected parties on the dates listed below.

Dealer Work Instruction (attached)
posted December 12, 2007 - Freightliner, Sterling, Western Star, and
Freightliner Custom Chassis
posted January 10, 2008 - Thomas Built Buses

Owner's Letter (attached)
mailed December 21, 2007 - Freightliner, Sterling, Western Star, and
Freightliner Custom Chassis
mailed January 18, 2008 - Thomas Built Buses

The correct count on Canadian vehicles affected is 1,216.

Please contact me if you have any questions.

Sincerely yours,



Nasser Zamani

Attachment
Via E-mail

A Daimler Company

Daimler Trucks North America LLC
4747 N. Channel Avenue
Portland OR 97217-7699
503-745-6910 Phone
503-745-5544 Fax
Nasser.Zamani@Freightliner.com

Subject: AAC Front Axle Tie Rod and Steering Arm Fasteners

Models Affected: Specific Freightliner Business Class M2, Century Class S/T, Classic, Classic XL, Columbia, Coronado, and FLD vehicles; Sterling A/L-Line and Acterra vehicles; Freightliner Custom Chassis B2/S2 school bus chassis (Thomas Built Buses Saf-T-Liner C2), MB shuttle bus chassis, MT45/55 step van chassis, and XC motorhome chassis; and Western Star 4900 vehicles manufactured between January 5, 2007, and May 17, 2007, with certain Axle Alliance Company front axles.

General Information

Freightliner LLC, on behalf of its Freightliner Trucks Division and its wholly owned subsidiaries, Sterling Truck Corporation, Freightliner Custom Chassis Corporation, and Western Star Truck Sales, Inc., has decided that a defect that relates to motor vehicle safety exists on the vehicles mentioned above.

There are approximately 20,000 vehicles involved in this campaign.

During front axle assembly, the fasteners that attach the steering arm or the tie rod arms to the spindle may have been over or under tightened. Incorrectly tightened fasteners may fatigue and fracture, resulting in a possible vehicle crash without prior warning.

The steering arm and tie rod arm fasteners will be replaced. The steering arm will be inspected for clearance to the king pin boss. If there is no clearance, the steering arm will be replaced. It is expected that very few vehicles (less than 1 percent) will require a steering arm replacement.

Additional Repairs

Dealers must complete all outstanding recall and field service campaigns prior to the sale or delivery of a vehicle. A Dealer will be liable for any progressive damage that results from its failure to complete campaigns before sale or delivery of a vehicle.

Owners may be liable for any progressive damage that results from its failure to complete campaigns within a reasonable time after receiving notification.

Work Instructions

Please refer to the attached work instructions. Prior to performing the campaign, check the vehicle for a completion sticker (Form WAR260).

Replacement Parts

Replacement kits are now available and can be obtained by ordering the kit number(s) listed below from your facing Parts Distribution Center. All vehicles require a kit. Because so few steering arms will require replacement, when needed, please refer to PartsPro for the appropriate part number of the steering arm for the specific vehicle. The most common steering arm part number is ABP P6803382501.

If our records show your dealership has ordered any vehicles involved in campaign number FL501A, a list of the customers and vehicle identification numbers will be available on AccessFreightliner.com. Please refer to this list when ordering parts for this recall.

Recall Campaign

December 2007
 FL501A
 NHTSA #07V-306

Table 1 - Replacement Parts for FL501A

Campaign Number	Kit Number	Part Description	Part Number	Qty. per Kit	Suggested Wholesale*
FL501A	25-FL501-000	Tie Rod Capscrew, M20 x 1.5 x 90	ABP P308676020022	4 ea	\$37.68 U.S. \$45.36 CAN
		Steer Arm Capscrew, M20 x 1.5 x 80	ABP P308676020025	2 ea	
		Loctite® 277	A6809890271	1 ea	
		Completion Sticker	WAR260	1 ea	

* Please charge all Direct Warranty Customers the above-listed price for the kit, as they are authorized to perform their own Recalls.

Table 1

Removed Parts

Please follow Warranty Failed Parts Tracking shipping instructions for the disposition of all removed parts.

Labor Allowance

Table 2 - Labor Allowance

NOTE: When replacing a steering arm, list both SRTs on the claim.

Campaign Number	Procedure	Time Allowed (hours)	SRT Code	Damage Code
FL501A	Inspect steering arm and remove/replace tie rod end and steering arm capscrews.	1.2	996-0734A	000-Modifiedx
	Additional time to remove/replace steering arm.	0.4	996-0734B	000-Modifiedx

Table 2

IMPORTANT: When the recall has been completed, locate the base completion label in the appropriate location on the vehicle, and attach the red completion sticker provided in the recall kit (Form WAR260). If the vehicle does not have a base completion label, clean a spot on the appropriate location of the vehicle and first attach the base completion label (Form WAR259). If a recall kit is not required or there is no completion sticker in the kit, write the recall number on a blank sticker and attach it to the base completion label.

Claims for Credit

You will be reimbursed for your parts, labor, and handling by submitting your claim through the Warranty system within 30 days of completing this campaign. Please reference the following information in QuickClaim®:

- Claim type is **Recall**.
- In the FTL Authorization field, enter the campaign number and appropriate condition code (**FL501A**).
- In the Primary Failed Part Number field, enter **25-FL501-000**.
- In the Parts field, enter the appropriate kit number(s) as shown in the Replacement Parts Table. All vehicles require a kit. However, because so few steering arms will require replacement, when needed, please refer to PartsPro for the appropriate part number of the steering arm for the specific vehicle.
- In the Labor field, first enter the appropriate SRT from the Labor Allowance Table. For administrative time, enter SRT 939-0010A for 0.4 hours for RVs or 0.3 hours for all other vehicles. NOTE: When replacing a steering arm, list both SRTs on the claim. Fewer than 1 percent are expected to need a steering arm replacement.

IMPORTANT: ServicePro® must be viewed prior to performing the recall to ensure the vehicle is involved and the campaign has not been previously completed. Also, check for a completion sticker prior to beginning work.

Recall Campaign

December 2007
FL501A
NHTSA #07V-306

Contact the Warranty Campaigns Department at (800) 547-0712, from 7:00 a.m. to 4:00 p.m. Pacific Time, Monday through Friday, Web inquiry at AccessFreightliner.com / Support / Submit an Inquiry, or the Customer Assistance Center at (800) 385-4357, after normal business hours, if you have any questions or need additional information.

To return excess kit inventory related to this campaign, U.S. dealers must submit a Parts Authorization Return (PAR) to the Memphis PDC. Canadian dealers must submit a PAR to their facing PDC. All kits must be in resalable condition. PAR requests must include the original purchase invoice number.

The letter notifying vehicle owners is included for your reference.

Please note that the National Traffic and Motor Vehicle Safety Act, as amended (Title 49, United States Code, Chapter 301), requires the owner's vehicle(s) be corrected within a reasonable time after parts are available to you. The Act states that failure to repair a vehicle within 60 days after tender for repair shall be prima facie evidence of an unreasonable time. However, circumstances of a particular situation may reduce the 60 day period. Failure to repair a vehicle within a reasonable time can result in either the obligation to (a) replace the vehicle with an identical or reasonably equivalent vehicle, without charge, or (b) refund the purchase price in full, less a reasonable allowance for depreciation. The Act further prohibits dealers from selling a vehicle unless all outstanding recalls are performed. Also, any lessor is required to send a copy of the recall notification to the lessee within 10 days.

Recall Campaign



December 2007
FL501A
NHTSA #07V-306

Copy of Letter to Owner Subject: AAC Front Axle Tie Rod and Steering Arm Fasteners

This notice is sent to you in accordance with the requirements of the National Traffic and Motor Vehicle Safety Act. This notice is also sent in accordance with the Canadian Motor Vehicles Safety Act.

Freightliner LLC, on behalf of its Freightliner Trucks Division and its wholly owned subsidiaries, Sterling Truck Corporation, Freightliner Custom Chassis Corporation, and Western Star Truck Sales, Inc., has decided that a defect which relates to motor vehicle safety exists on specific Freightliner Business Class M2, Century Class S/T, Classic, Classic XL, Columbia, Coronado, and FLD vehicles; Sterling A/L-Line and Acterra vehicles; Freightliner Custom Chassis B2/S2 school bus chassis (Thomas Built Buses Saf-T-Liner C2), MB shuttle bus chassis, MT45/55 step van chassis, and XC motorhome chassis; and Western Star 4900 vehicles manufactured between January 5, 2007, and May 17, 2007, with certain Axle Alliance Company front axles.

During front axle assembly, the fasteners that attach the steering arm or the tie rod arms to the spindle may have been over or under tightened. Incorrectly tightened fasteners may fatigue and fracture, resulting in a possible vehicle crash without prior warning.

The steering arm and tie rod arm fasteners will be replaced. The steering arm will be inspected for clearance to the king pin boss.

Parts are now available for authorized dealers to order. Contact your authorized dealer to arrange to have your vehicle(s) modified and to assure that parts are available at the dealer. To locate a dealer, search online at www.FreightlinerTrucks.com, www.SterlingTrucks.com, or contact the Warranty Campaigns Department for assistance.

When you contact your dealer, refer to campaign number **FL501A**. Once kit(s) are received at the dealership, the Recall will take approximately an hour and a half will be performed at no charge to you.

IMPORTANT: When the Recall has been completed, please ensure that a label has been affixed to your vehicle referencing **FL501A**.

If you do not own the vehicle that corresponds to the identification number(s) which appears on the Recall Notification, please return the notification to the Warranty Campaigns Department with any information you can furnish that will assist us in locating the present owner. If you have leased this vehicle, Federal law requires that you forward this notice to the lessee within 10 days. If you are a subsequent stage manufacturer, Federal law requires that you forward this notice to your distributors and retail outlets within five working days.

If you are not able to have the defect remedied without charge and within a reasonable time, which is not longer than 60 days after you tender the vehicle for repair, please contact the Warranty Campaigns Department at (800) 547-0712, 7:00 a.m. to 4:00 p.m. Pacific Time, Monday through Friday, e-mail address WarrantyCampaigns@freightliner.com, or the Customer Assistance Center at (800) FTL-HELP or (800) STL-HELP, after normal business hours. You may also wish to submit a complaint to the Administrator, National Highway Traffic Safety Administration, 1200 New Jersey Avenue, SE., Washington, DC 20590; or call the Vehicle Safety Hotline at (888) 327-4236 (TTY: 800-424-9153); or to <http://www.safercar.gov>. If your vehicle is involved in the Canadian portion, you may wish to notify Transport Canada, ASFAD, Place de Ville Tower C, 330 Sparks Street, Ottawa, ON K1A 0N5, or phone (800) 333-0510.

We regret any inconvenience this action may cause but feel certain you understand our interest in motor vehicle safety.

WARRANTY CAMPAIGNS DEPARTMENT

Enclosure

Work Instructions

Subject: AAC Front Axle Tie Rod and Steering Arm Fasteners

Models Affected: Specific Freightliner Business Class M2, Century Class S/T, Classic, Classic XL, Columbia, Coronado, and FLD vehicles; Sterling A/L-Line and Acterra vehicles; Freightliner Custom Chassis B2/S2 school bus chassis (Thomas Built Buses Saf-T-Liner C2), MB shuttle bus chassis, MT45/55 step van chassis, and XC motorhome chassis; and Western Star 4900 vehicles manufactured between January 5, 2007, and May 17, 2007, with certain Axle Alliance Company front axles.

NOTE: All vehicles require kit 25-FL501-000. However, few steering arms will require replacement. If a steering arm must be replaced, please refer to PartsPro for the appropriate steering arm part number for the specific vehicle. The most common steering arm part number is ABP P6803382501. Fewer than 1 percent are expected to need a steering arm replacement.

Steering Arm Inspection

1. Check the base label (Form WAR259) for a completion sticker for FL501 (WAR260) indicating this work has been done. The base label is usually located on the passenger-side door about 12 inches (30 cm) below the door latch on trucks, over the driver's window in school buses, on the front wall under the dash in motorhomes, or in the driver's area in step vans. If a completion sticker for FL501 is present, nothing more needs to be done. If no sticker is present, go to the next step.
2. Shut down the engine, and chock the front tires.
3. Using a 0.004 inch (0.1 mm) feeler gauge, check the clearance between the steering arm and the king pin boss. See Fig. 1.

If there is clearance, go to the "Steering Arm Capscrew Replacement" and "Tie Rod Arm Capscrew Replacement" procedures in these Work Instructions.

If there is **no clearance**, the steering arm must be replaced. Go to the "Steering Arm Replacement" procedure in these Work Instructions.

Steering Arm Capscrew Replacement

IMPORTANT: The following steps apply to both steering arm capscrews. Replace one capscrew at a time to avoid loosening the arm completely.

1. Remove one of the capscrews that attaches the steering arm to the steering knuckle. See Fig. 1.
2. Check the capscrew threads to verify whether Loctite® or another thread locking compound was applied to them.

If a thread locking compound is present on the capscrew, clean the female threads on the steering knuckle, removing all dirt, oil, and other foreign material. If parts are contaminated, use a petroleum solvent for cleaning; then allow the threads to air dry for 10 minutes. Be sure the solvent is completely gone before applying adhesive.

3. Apply Loctite 277 to the threads of a new M20 x 1.5 x 80 capscrew from the Recall kit.
4. Install the new steering arm capscrew and tighten it 425 lbf-ft (575 N-m).
5. Repeat steps 1 through 4 to replace the second capscrew.
6. Continue with the "Tie Rod Arm Capscrew Replacement" procedure in these Work Instructions.

Recall Campaign

December 2007
FL501A
NHTSA #07V-306

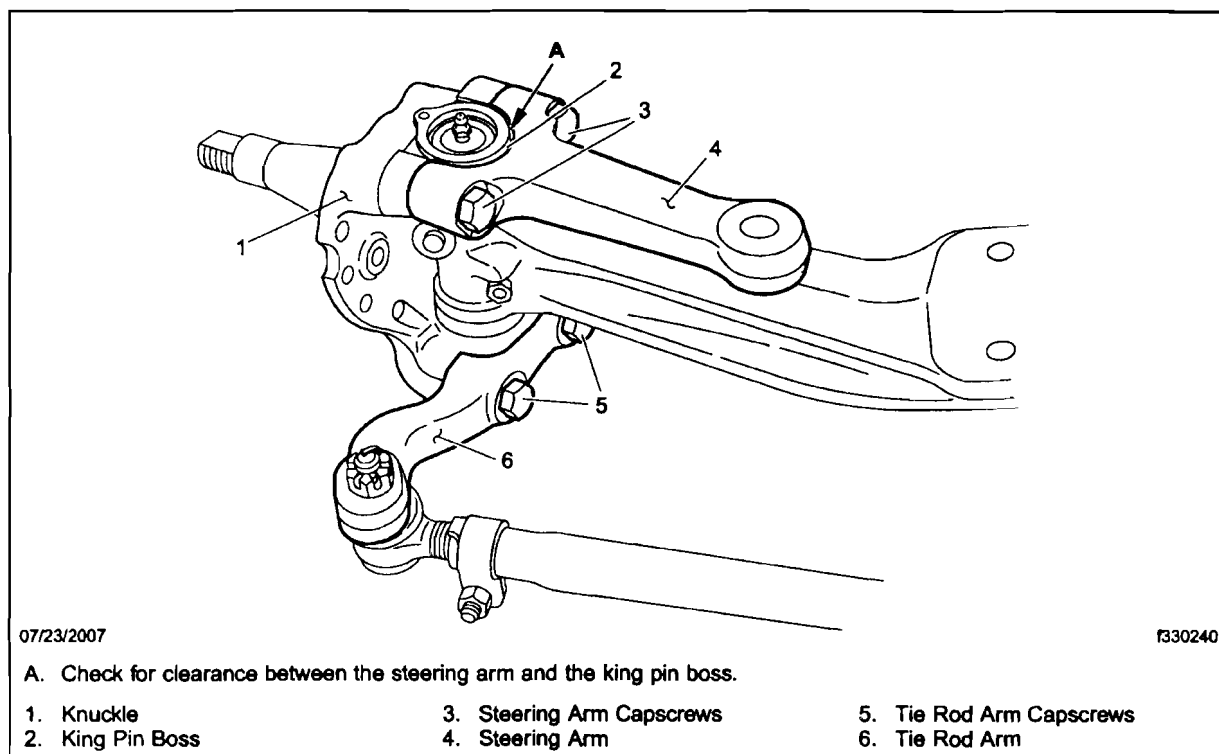

Fig. 1, Steering Arm and Tie Rod Arm

Tie Rod Arm Capscrew Replacement

IMPORTANT: The following steps apply to both tie rod arm capscrews at both the RH and LH sides of the front axle. Replace one capscrew at a time to avoid loosening an arm completely.

1. Remove one of the capscrews that attaches the tie rod arm to the knuckle. See Fig. 1.
2. Check the capscrew threads to verify whether Loctite® or another thread locking compound was applied to them.

If a thread locking compound is present on the capscrew, clean the female threads on the knuckle, removing all dirt, oil, and other foreign material. If parts are contaminated, use a petroleum solvent for cleaning; then allow the threads to air dry for 10 minutes. Be sure the solvent is completely gone before applying adhesive.
3. Apply Loctite 277 to the threads of a new M20 x 1.5 x 90 capscrew.
4. Install the new tie rod arm capscrew and tighten it 425 lbf-ft (575 N-m).
5. Repeat steps 1 through 4 until all four of the tie rod arm capscrews have been replaced.
6. Clean a spot on the base label (Form WAR259) and attach a completion sticker for Recall FL501 (Form WAR 260) to the base label.
7. Remove the chocks.

Steering Arm Replacement

1. Remove both of the capscrews that attach the steering arm to the steering knuckle, and remove the steering arm.
2. Check the capscrew threads to verify whether Loctite or another thread locking compound was applied to them.

If a thread locking compound is present on the capscrew, clean the female threads on the steering knuckle, removing all dirt, oil, and other foreign material. If parts are contaminated, use a petroleum solvent for cleaning; then allow the threads to air dry for 10 minutes. Be sure the solvent is completely gone before applying adhesive.

3. Apply Loctite 277 to the threads of two new M20 x 1.5 x 80 capscrews.
4. Install a new steering arm with its engraved part number facing upward.
5. Install the new steering arm capscrews and tighten them 425 lbf-ft (575 N·m).
6. Go to the "Tie Rod Arm Capscrew Replacement" procedure in these Work Instructions.