

DAIMLER



Daimler Trucks North America
Nasser Zamani
Manager
Compliance and Regulatory Affairs

June 12, 2008

Dan Smith
Associate Administrator for Vehicle Safety
National Highway Traffic Safety Administration
1200 New Jersey Avenue S.E.
Washington D.C. 20590

**Re: Defect Information Report – Supplemental Report No. 2
08V-029, FL-521, Air Disk Brake Mounting Bolts**

Mr. Smith

In accordance with Part 573 of Title 49 of the Code of Federal Regulations, Daimler Trucks North America LLC herewith submits supplemental defect information and copies of documents to be distributed to dealers and purchasers.

- (c)(3) Total number of vehicles potentially affected: 473**
- (c) (8)(ii) Communications sent to dealers: posted May 31, 2008
Communications sent to owners: mailed June 6, 2008**
- (c) (10) Copies of Communications sent to owners and dealers are attached.
Copies of Pre-Recall Notice sent to Tiffin Motorhomes and Triple E
Recreational Vehicles are attached.**

Please contact me if you have any questions.

Sincerely yours,

Nasser Zamani

Cc: Michael Mason, CAL-OSHA
Enclosure
Certified Mail# 7004 2890 0004 1202 2298

A Daimler Company

Daimler Trucks North America LLC
4747 N. Channel Avenue
Portland OR 97217-7699
503-745-6910 Phone
503-745-5544 Fax
NasserZamani@Freightliner.com

Subject: Air Disk Brake Caliper Bolts

Models Affected: Specific Freightliner Argosy, Business Class M2, Cascadia, Century Class S/T, and Columbia vehicles and Freightliner Custom Chassis XC-R motor home chassis manufactured between January 1, 2007, and November 19, 2007, with air disk brakes.

General Information

Daimler Trucks North America LLC, on behalf of its Freightliner Trucks Division and its wholly owned subsidiary, Freightliner Custom Chassis Corporation, has decided that a defect that relates to motor vehicle safety exists on the vehicles mentioned above.

There are approximately 700 vehicles involved in this campaign.

Standard fasteners may have been used rather than metric fasteners to attach the brake caliper to the brake anchor plate. Incorrect fasteners may not provide adequate clamping force between the brake caliper and the brake anchor plate. This may reduce brake effectiveness, resulting in a possible vehicle crash.

Potentially affected brake caliper bolts will be inspected. The bolts will be replaced on any caliper that has one or more incorrect bolts. The expected replacement rate is 16 percent.

Additional Repairs

Dealers must complete all outstanding recall and field service campaigns prior to the sale or delivery of a vehicle. A Dealer will be liable for any progressive damage that results from its failure to complete campaigns before sale or delivery of a vehicle.

Owners may be liable for any progressive damage that results from its failure to complete campaigns within a reasonable time after receiving notification.

Work Instructions

Please refer to the attached work instructions. Prior to performing the campaign, check the vehicle for a completion sticker (Form WAR260).

Replacement Parts

Replacement kits are now available and can be obtained by ordering the kit number(s) listed below from your facing Parts Distribution Center. **Please note the small number of vehicles involved and the low expected replacement rate and take this into account when ordering kits for this recall.**

If our records show your dealership has ordered any vehicles involved in campaign number FL521AB, a list of the customers and vehicle identification numbers will be available on AccessFreightliner.com. Please refer to this list when ordering parts for this recall.

Table 1 - Replacement Parts for FL521AB

NOTE: One kit contains replacement parts for one caliper. The same kit is used for calipers on both front and rear axles. The expected replacement rate is 16%.

If a Freightliner truck (FL521B only) requires replacement of bolts on a rear axle (this is expected to be very rare, if needed at all), contact the Warranty Campaigns Department by submitting an inquiry via www.AccessFreightliner.com for instructions and shipment of a special tool to complete this repair. This does not affect the performance of the recall for calipers on the front axle.

Recall Campaign

Daimler Trucks
North America LLC

May 2008
FL521AB
NHTSA #08V-029

Campaign Number	Kit Number	Part Description	Part Number	Qty. per Kit	Suggested Wholesale*
FL521AB	25-FL521-000	Bolt, M20X2.5X60	MBT N210931020001	6 ea	\$22.69 U.S. \$22.69 CAN
		Washer-Flat, Hardened, M20, ZN	MBT N221822020000	6 ea	
		Completion Sticker	WAR260	1 ea	

* Please charge all Direct Warranty Customers the above-listed price for the kit, as they are authorized to perform their own Recalls.

Table 1

Removed Parts

Please follow Warranty Failed Parts Tracking shipping instructions for the disposition of all removed parts.

Labor Allowance

Table 2 - Labor Allowance

Campaign Number	Procedure	Time Allowed (hours)	SRT Code	Damage Code
FL521AB	Inspect brake caliper bolts.	0.2	996-0756A	000-Inspected
FL521AB	Inspect and replace brake caliper bolts on 1 caliper.	0.4	996-0756B	000-Modifiedx
FL521AB	Inspect and replace brake caliper bolts on 2 calipers.	0.7	996-0756C	000-Modifiedx
FL521B	Inspect and replace brake caliper bolts on 3 calipers.	1.1	996-0756D	000-Modifiedx
FL521B	Inspect and replace brake caliper bolts on 4 calipers.	1.4	996-0756E	000-Modifiedx
FL521B	Inspect and replace brake caliper bolts on 5 calipers.	1.8	996-0756F	000-Modifiedx
FL521B	Inspect and replace brake caliper bolts on 6 calipers.	2.1	996-0756G	000-Modifiedx

Table 2

IMPORTANT: When the recall has been completed, locate the base completion label in the appropriate location on the vehicle, and attach the red completion sticker provided in the recall kit (Form WAR260). If the vehicle does not have a base completion label, clean a spot on the appropriate location of the vehicle and first attach the base completion label (Form WAR259). If a recall kit is not required or there is no completion sticker in the kit, write the recall number on a blank sticker and attach it to the base completion label.

Claims for Credit

You will be reimbursed for your parts, labor, and handling by submitting your claim through the Warranty system within 30 days of completing this campaign. Please reference the following information in QuickClaim®:

- Claim type is **Recall**.
- In the FTL Authorization field, enter the campaign number and appropriate condition code (**FL521A** or **FL521B**).
- In the Primary Failed Part Number field, enter **25-FL521-000**.
- In the Parts field, enter the appropriate kit number(s) as shown in the Replacement Parts Table. NOTE: One kit contains replacement parts for one caliper. The same kit is used for both front and rear axles.

- In the Labor field, first enter the appropriate SRT from the Labor Allowance Table. For administrative time, enter SRT 939-0010A for 0.4 hours for motor homes or 0.3 hours for all other vehicles.
- If any Freightliner truck in FL521B requires replacement of caliper bolts on a rear axle (this is expected to be very rare), contact the Warranty Campaigns Department by submitting an inquiry via www.AccessFreightliner.com for instructions and shipment of a special tool to complete this repair. This does not affect the performance of the recall for calipers on the front axle.
- **Reimbursement for Prior Repairs.** When a customer asks about reimbursement, please do the following.
 - Accept the documentation of the previous repair.
 - Make a brief check of the customer's paperwork to see if the repair may be eligible for reimbursement. (See the "Copy of Owner Letter" section of this bulletin for reimbursement guidelines for this recall.)
 - Contact the Warranty Campaigns Department for a decision and authorization number.
 - Include the approved amount on your claim in sublet/outside purchases.
 - In the claim story, first note the authorization number and that the claim includes a reimbursement request.
 - Retain the documentation and provide it to Warranty Campaigns or Claims Processing if requested.
 - When your claim is paid, reimburse the customer the appropriate amount.

IMPORTANT: ServicePro® must be viewed prior to performing the recall to ensure the vehicle is involved and the campaign has not been previously completed. Also, check for a completion sticker prior to beginning work.

Contact the Warranty Campaigns Department at (800) 547-0712, from 7:00 a.m. to 4:00 p.m. Pacific Time, Monday through Friday, Web inquiry at AccessFreightliner.com / Support / Submit an Inquiry, or the Customer Assistance Center at (800) 385-4357, after normal business hours, if you have any questions or need additional information.

To return excess kit inventory related to this campaign, U.S. dealers must submit a Parts Authorization Return (PAR) to the Memphis PDC. Canadian dealers must submit a PAR to their facing PDC. All kits must be in resalable condition. PAR requests must include the original purchase invoice number.

The letter notifying vehicle owners is included for your reference.

Please note that the National Traffic and Motor Vehicle Safety Act, as amended (Title 49, United States Code, Chapter 301), requires the owner's vehicle(s) be corrected within a reasonable time after parts are available to you. The Act states that failure to repair a vehicle within 60 days after tender for repair shall be prima facie evidence of an unreasonable time. However, circumstances of a particular situation may reduce the 60 day period. Failure to repair a vehicle within a reasonable time can result in either the obligation to (a) replace the vehicle with an identical or reasonably equivalent vehicle, without charge, or (b) refund the purchase price in full, less a reasonable allowance for depreciation. The Act further prohibits dealers from selling a vehicle unless all outstanding recalls are performed. Any lessor is required to send a copy of the recall notification to the lessee within 10 days. Any subsequent stage manufacturer is required to forward this notice to its distributors and retail outlets within five working days.

Recall Campaign

Daimler Trucks
North America LLC

May 2008
FL521AB
NHTSA #08V-029

Copy of Letter to Owner Subject: Air Disk Brake Caliper Bolts

This notice is sent to you in accordance with the requirements of the National Traffic and Motor Vehicle Safety Act. This notice is also sent in accordance with the Canadian Motor Vehicles Safety Act.

Daimler Trucks North America LLC, on behalf of its Freightliner Trucks Division and its wholly owned subsidiary, Freightliner Custom Chassis Corporation, has decided that a defect which relates to motor vehicle safety exists on specific Freightliner Argosy, Business Class M2, Cascadia, Century Class S/T, and Columbia vehicles and Freightliner Custom Chassis XC-R motor home chassis manufactured between January 1, 2007, and November 19, 2007, with air disk brakes.

Standard fasteners may have been used rather than metric fasteners to attach the brake caliper to the brake anchor plate. Incorrect fasteners may not provide adequate clamping force between the brake caliper and the brake anchor plate. This may reduce brake effectiveness, resulting in a possible vehicle crash.

Potentially affected brake caliper bolts will be inspected. The bolts will be replaced on any caliper that has one or more incorrect bolts.

Parts are now available for authorized dealers to order. Contact your authorized dealer to arrange to have the recall completed and to ensure that parts are available at the dealership. Please note, in rare cases, additional parts may need to be ordered after the vehicle is inspected. To locate a dealer, search online at www.FreightlinerTrucks.com or contact the Warranty Campaigns Department for assistance.

When you contact your dealer, refer to campaign number **FL521AB**. Once kit(s) are received at the dealership, the recall will take between approximately half an hour and an hour (rarely up to two and a half hours), depending on the work needed, and will be performed at no charge to you.

IMPORTANT: When the Recall has been completed, please ensure that a label has been affixed to your vehicle referencing **FL521AB**.

If you do not own the vehicle that corresponds to the identification number(s) which appears on the Recall Notification, please return the notification to the Warranty Campaigns Department with any information you can furnish that will assist us in locating the present owner. If you have leased this vehicle, Federal law requires that you forward this notice to the lessee within 10 days. If you are a subsequent stage manufacturer, Federal law requires that you forward this notice to your distributors and retail outlets within five working days. If you have paid to have this recall condition corrected prior to this notice, you may be eligible to receive reimbursement. Please see the reverse side of this notice for details.

If you are not able to have the defect remedied without charge and within a reasonable time, which is not longer than 60 days after you tender the vehicle for repair, please contact the Warranty Campaigns Department at (800) 547-0712, 7:00 a.m. to 4:00 p.m. Pacific Time, Monday through Friday, e-mail address WarrantyCampaigns@freightliner.com, or the Customer Assistance Center at (800) FTL-HELP or (800) STL-HELP, after normal business hours. You may also wish to submit a complaint to the Administrator, National Highway Traffic Safety Administration, 1200 New Jersey Avenue, SE., Washington, DC 20590; or call the Vehicle Safety Hotline at (888) 327-4236 (TTY: 800-424-9153); or to <http://www.safercar.gov>. If your vehicle is involved in the Canadian portion, you may wish to notify Transport Canada, ASFAD, Place de Ville Tower C, 330 Sparks Street, Ottawa, ON K1A 0N5, or phone (800) 333-0510.

We regret any inconvenience this action may cause but feel certain you understand our interest in motor vehicle safety.

WARRANTY CAMPAIGNS DEPARTMENT

Enclosure

Reimbursement to Customers for Repairs Performed Prior to Recall

If you have already **paid** to have this recall condition corrected you may be eligible to receive reimbursement.

Requests for reimbursement may include parts and labor. Reimbursement may be limited to the amount the repair would have cost if completed by an authorized Daimler Trucks North America LLC dealer. The following documentation must be presented to your dealer for consideration for reimbursement.

Please provide original or clear copies of all receipts, invoices, and repair orders that show:

- The name and address of the person who paid for the repair.
- The Vehicle Identification Number (VIN) of the vehicle that was repaired.
- What problem occurred, what repair was done, when the repair was done.
- Who repaired the vehicle.
- The total cost of the repair expense that is being claimed.
- Proof of payment for the repair (such as the front and back of a cancelled check or a credit card receipt).

Reimbursement will be made by check from your Daimler Trucks North America LLC dealer.

Please speak with your Daimler Trucks North America LLC authorized dealer concerning this matter.

May 2008
FL521AB
NHTSA #08V-029

Work Instructions

Subject: Air Disk Brake Caliper Bolts

Models Affected: Specific Freightliner Argosy, Business Class M2, Cascadia, Century Class S/T, and Columbia vehicles and Freightliner Custom Chassis XC-R motor home chassis manufactured between January 1, 2007, and November 19, 2007, with air disk brakes.

IMPORTANT: If any Freightliner truck in FL521B requires replacement of caliper bolts on a rear axle (this is expected to be very rare), contact the Warranty Campaigns Department by submitting an inquiry via www.AccessFreightliner.com for shipment of a special tool and instructions to complete this repair. This does not affect the performance of the recall for calipers on the front axle.

Caliper Anchor Plate Bolt Inspection – Front and Rear Axles

1. Check the base label (Form WAR259) for a completion sticker for FL521 (Form WAR260) indicating this work has been done. On trucks, the base label is usually located on the passenger-side door about 12 inches (30 cm) below the door latch. On motor homes, the base label is usually located on the front wall under the dash. If a sticker for FL521 is present, nothing further needs to be done. If no sticker is present, go to the next step.

NOTE: Finish the front axle inspection before replacing any bolts, if replacement is needed. The expected replacement rate is 16 percent.

2. On each caliper on the front axle (FL521A and FL521B), inspect each anchor plate bolt to ensure it has "10.9" stamped on the bolt head. Inspect all front axle calipers. See Fig. 1.
3. On FCCC motor home chassis (FL521A), if all bolts ARE marked "10.9," clean a spot on the base label, write the recall number, FL521, on a blank red completion sticker, and attach it to the base label. If any bolt on the front axle is NOT marked "10.9," replace all bolts on that caliper. Go to "Caliper Anchor Plate Bolt Replacement – Front Axle."

On Freightliner trucks (FL521B), using the inspection steps above, inspect the calipers on the rear axle(s). It is not necessary to raise the vehicle, the bolts are visible by leaning over the rear tires and looking behind the wheels.

4. If all bolts on the front and rear axles ARE marked "10.9," no further work is needed. Clean a spot on the base label, write the recall number, FL521, on a blank red completion sticker, and attach it to the base label.

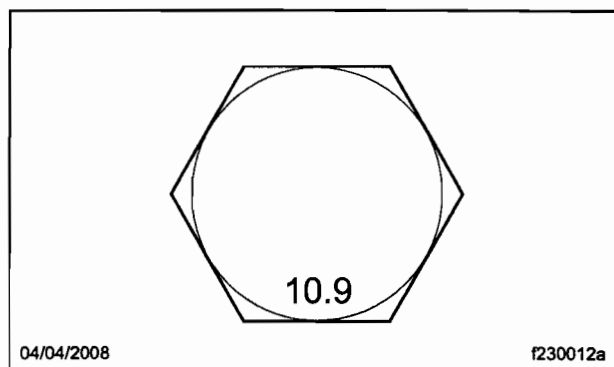

Fig. 1, Bolt Strength Identification

May 2008
FL521AB
NHTSA #08V-029

If any bolt on the front axle is NOT marked "10.9," replace all bolts on that caliper. Go to "Caliper Anchor Plate Bolt Replacement – Front Axle."

If any bolt on the rear axle is NOT marked "10.9," contact the Warranty Campaigns Department by submitting an inquiry via www.AccessFreightliner.com. A special tool and instructions for replacing caliper bolts on the rear axle will be shipped.

NOTE: Replacement of caliper bolts on a rear axle is expected to be very rare, if needed at all.

Caliper Anchor Plate Bolt Replacement – Front Axle

1. Park the vehicle on a level surface. Shut down the engine, set the parking brake, and chock the rear tires.

WARNING

Whenever the vehicle is raised, support the vehicle with adequate safety stands. Do not work under or around a vehicle supported only by jacks. Jacks can slip, allowing the vehicle to fall, which could result in personal injury or death.

2. Raise the front of the vehicle and turn the wheels all the way one direction. Lower the vehicle.
3. Remove one caliper mounting bolt (leaving the others in place) and discard it. See Fig. 2, Ref. A.

CAUTION

Breathing brake lining dust (asbestos or non-asbestos) could cause lung cancer or lung disease. OSHA has set maximum levels of exposure and requires workers to wear an air purifying respirator approved

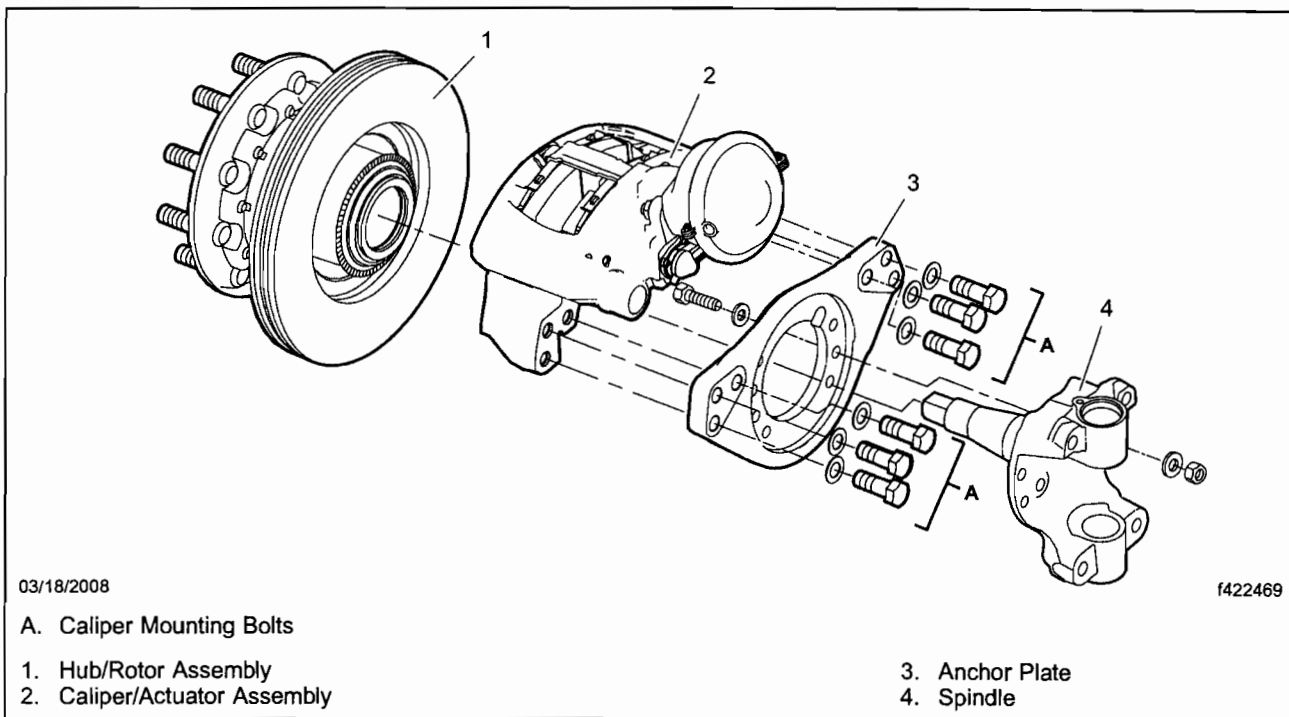

Fig. 2, Steer Axle Components

Recall Campaign

Daimler Trucks
North America LLC

May 2008
FL521AB
NHTSA #08V-029

by NIOSH or MSHA. Wear a respirator at all times when servicing the brakes, starting with removal of the wheels and continuing through assembly.

Always wear eye protection when using compressed air. Eye damage can occur from flying debris.

4. Using compressed air, blow any Loctite® residue from the bolt hole.

IMPORTANT: If damage is found at any time during this process, replace the damaged components before continuing.

5. Hand-start the new bolt, then turn it in and out with an impact wrench, if available, to clean out the threads. Do not over tighten. Remove the bolt, blow out the hole, then, blow any residue off the bolt.
6. Apply Loctite to the bolt threads, then install the bolt through the caliper mounting bracket. Tighten the bolt 355 to 375 lbf-ft (480 to 510 N·m).
7. Repeat the previous steps for each of the three bolts on the accessible side of the caliper.
8. Go to the other side of the vehicle and repeat the steps for the accessible bolts on that side.
9. Raise the front of the vehicle and turn the wheels all the way in the opposite direction. Lower the vehicle.
10. Repeat the previous steps for the remaining bolts on both sides of the vehicle.
11. Clean a spot on the base completion label. Attach a completion sticker for FL521 to the base label.
12. Remove the tire chocks.

**Daimler Trucks
North America LLC**

Daimler Trucks North America LLC
P.O. Box 4090
Portland, OR 97208-4090
800.547.0712 Phone
503.745.9009 Fax

**April 2008
FL521
Pre-Recall Notice**

**Notice of Submission of Defect Information Report/Defect Information Notice
Subject: Air Disk Brake Caliper Bolts**

Daimler Trucks North America has determined that a safety related defect exists in certain chassis manufactured by Freightliner Custom Chassis Corporation and delivered to your company. As the incomplete vehicle manufacturer of these products, Daimler Trucks North America is unable to provide the National Highway Traffic Safety Administration and/or Transport Canada with the information necessary to fully describe the vehicles potentially containing this defect as required by Title 49 Code of Federal Regulations Part 573.6(c)(2) and/or Motor Vehicle Safety Regulations Section 15(1)(b). Your company may have an obligation to report this information.

The attached Defect Information Report and Defect Information Notice were filed with the appropriate government agencies on January 17, 2008. Please refer to these notices for details regarding the nature of the defect, the remedy, and the expected date when the remedy without charge will be available to owners. Daimler Trucks North America will be conducting this recall and filing the quarterly reports required by Title 49 CFR §573.7 and/or MVSR §15(3). Repairs will be performed by authorized Daimler Trucks North America repair facilities.

A preliminary list of potentially affected vehicles delivered to you is included.

This is the first letter in regard to this recall that you will receive. You will receive another letter when Daimler Trucks North America notifies its dealers and owners that a remedy without charge for this issue is available.

If you have questions regarding this notice, please contact the Warranty Campaigns Department at (800) 547-0712, 7:00 a.m. to 4:00 p.m. Pacific Time, Monday through Friday, e-mail address WarrantyCampaigns@Freightliner.com.

WARRANTY CAMPAIGNS DEPARTMENT
Enclosure