

Safety Recall ALERT

Date: December 12, 2007 **Number:** SRA-07-07
To: All U.S. & Canadian Distributors
Attention: Service Manager, Warranty Manager, Parts Manager, Dealer Principal
From: Regulatory Affairs Department
Subject: Safety Recall, RVXX0707, Circuit Breaker

Safety Recall Summary:

On certain Volvo VHD, VNL, VNM, and VT model vehicles manufactured from November 2002 through October 2007, the circuit protection (i.e. automatic circuit breakers) used to protect the vehicle lighting system may not provide adequate protection. If a short circuit occurs and is left untreated, components and wiring may be subject to overheating which could potentially result in a vehicle fire.

The number of vehicles affected is approximately 125,000 (104,845 US and 14,742 Canada and 5,413 Export).

Dealer's Responsibility:

The National Traffic and Motor Vehicle Safety Act and Canadian Motor Vehicle Safety Act requires dealers to ensure that all new and used vehicles are free of safety defects and comply with all relevant safety standards at the time of delivery to the consumer.

Dealers should make their personnel aware of the safety recall. In the event that a dealer has a vehicle included in the safety recall in their inventory to be sold, the condition must be corrected before releasing it to a customer.

Release Schedule:

- Repair Instructions are tentatively scheduled for release no later than February 14, 2008.
- Vehicle list will be posted on the Trucks Dealer Portal December 12, 2007.
- Owner Notices are scheduled to be mailed on or before February 25, 2008.

Questions:

Contact the Regulatory Affairs Department at vtna.regulatoryaffairs@volvo.com if you have questions.

SAFETY RECALL BULLETIN

**ATTENTION: SERVICE MANAGERS
PARTS MANAGERS**

SUBJECT: Steering Gear Mounting Fastener Torque

SAFETY RECALL INFORMATION:

The bolts that attach the steering gear to the frame may not have been tightened to the correct torque.

VEHICLES AFFECTED:

Certain VNL, VNM, and VT model vehicles manufactured from July 2, 2007 through September 21, 2007.

There are 2,084 vehicles (1,491 US; 226 Canada; 367 Export) affected by this recall.

NOTE: To verify or determine if a particular vehicle is affected by this recall (or any other recall), you should enter the Vehicle Identification Number into the VIN search field in eWarranty, and the screen will display any open recall.

If a "Dealer Listing" is enclosed it identifies the vehicles that were sold or shipped to your dealership. Be sure to check the eWarranty Vehicle Detail screen before performing the recall to verify that the recall is still open.

REPAIR:

The recall repair will consist of tightening the bolts.

TIME ALLOWANCE:

0.3 hour per vehicle

Note: If the recall repair is the only repair being administered, then a take charge time allowance of 0.3 hrs can be claimed.

PART ORDERING PROCEDURES:

There are no parts required for this recall

DEALER PARTS INVENTORY:

Dealer parts inventory is not affected by this recall.

CLAIMS FOR CREDIT:

Expenses associated with the performance of this recall will be reimbursed based on the guidelines identified in this bulletin, and section 2-41 of the Warranty Manual, Policies and Procedures and chapter 20 of the Parts Operations Manual.

CLAIM CODING INFORMATION:

Authorization Number: RVXX0706

Causal Part Number: 963347

STANDARD REPAIR CODES AND TIME:

Repair: 64231-0-02 (0.3 hour)

Take charge time (if applicable): 17003-0-01 (0.3 hour)

IMPORTANT NOTE: Claims for a recall repair **MUST** be submitted within 2 working days from the repair date.

OWNER RECALL RESPONSE CARD:

The "Owner Recall Response Card" is to provide the vehicle owner with a convenient way to notify Volvo Trucks North America of changes affecting the ownership of the subject vehicle. The owner recall response card is not intended for dealer usage other than to assist you in the preparation of the repair orders necessary to perform the applicable recall on the subject vehicle. Please do not use the card as a way to inform Volvo Trucks North America that the vehicle has been inspected or modified. Your DCS claim on line is the appropriate means of informing Volvo Trucks North America that the vehicle has been inspected or modified.

DEALER RECALL RESPONSIBILITY:

Dealers are to perform the recall on all vehicles subject to the recall at no charge to the owner regardless of mileage, age of vehicle, or ownership from this time forward. Whenever a vehicle subject to this recall is taken into or is in your vehicle inventory or dealership for service, we strongly recommend you make every effort to perform the recall correction before the vehicle is sold or released to the owner.



IMPORTANT NOTICE:

Please note that the National Traffic and Motor Vehicle Safety Act requires that the owner's vehicle(s) be corrected at no charge and within a reasonable time after parts are available to you. The law states that failure to repair a vehicle within sixty (60) days after tender for repair shall be a prima facia evidence of unreasonable time. However, circumstances of a particular situation may reduce the sixty-day period. If an owner's vehicle is not repaired within a reasonable time, he or she may be entitled, without charge, to a reasonable equivalent vehicle or refund of the purchase price, less reasonable allowance for depreciation.

Repair Procedures:

You must read and understand the precautions and guidelines in Service Information, group 60, "General Safety Practices" before performing this procedure. If you are not properly

1. Park the vehicle on a level surface, apply the park brakes and block the wheels to prevent the vehicle from moving, and place the transmission in neutral.

2.

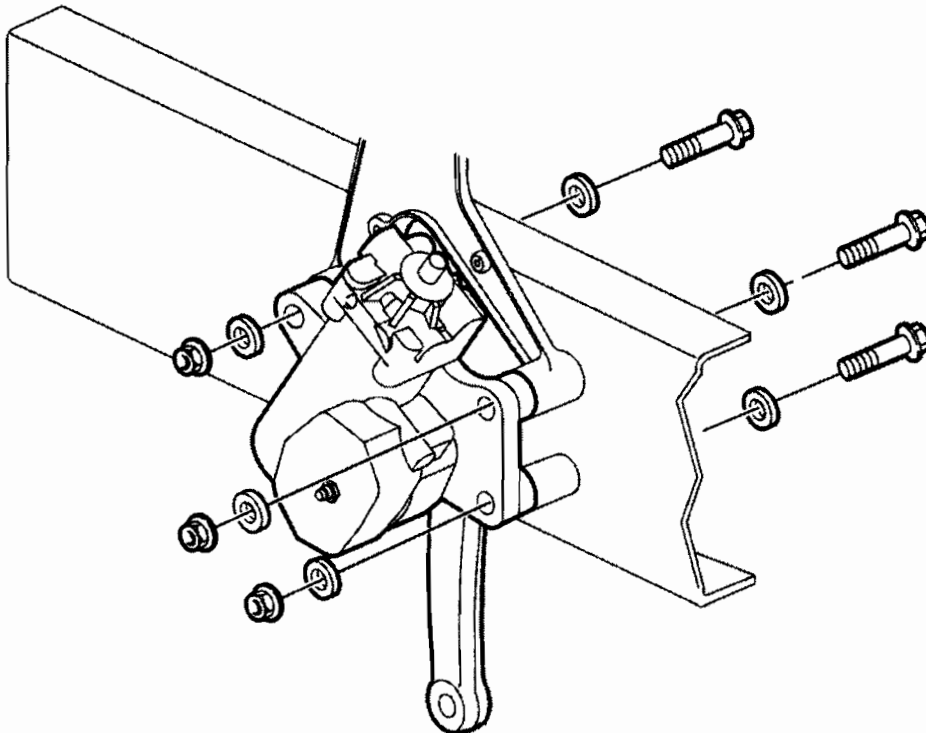

W6001615

Using an accurately calibrated torque wrench on the mounting nuts (outer) and a wrench on the bolts (inner), tighten the fasteners to 398 ± 66 ft-lb (540 ± 90 Nm). **Note:** Some vehicle may have four bolts securing the steering gear.

3. Mark each nut with a yellow paint stick to signify that the fasteners have been torqued to specification.

**SAFETY RECALL RVXX0706
DECEMBER 2007**

DEAR VOLVO TRUCK OWNER:

This notice is sent to you in accordance with the requirements of the National Traffic and Motor Vehicle Safety Act.

Volvo Trucks North America has decided that a defect which relates to motor vehicle safety exists in certain Volvo VNL, VNM, and VT model vehicles manufactured from July 2007 through September 2007.

SAFETY DEFECT: There exists the potential that the bolts that attach the steering gear to the frame may not have been tightened to the correct torque.

SAFETY RISK: If the condition exists, there is a possibility that loss of steering control could occur increasing the risk of a crash.

PRECAUTIONS YOU CAN TAKE: There are no precautions you can take other than having your vehicle inspected and repaired (if required) by a Volvo Parts and Service Center.

TIME REQUIRED FOR THE REPAIR: The labor time required to inspect your vehicle is approximately one hour.

WHAT YOU SHOULD DO: You should contact the nearest Volvo Parts and Service Center and make an appointment. The steering gear bolts will be retightened to the correct torque at no charge to you. All Volvo Parts and Service Centers have been sent a bulletin covering all the details required to perform the safety recall.

You can locate the closest Volvo Parts and Service Center by going on line to <http://www.volvo.com/trucks/na/en-us/dealers/> and selecting "Dealer Locator" or by calling our toll-free number: (800) 528-6586.

NOTICE REGARDING LEASED VEHICLES: If you are a Lessor of vehicles subject to this Notice, you have an obligation under Federal Law to provide a copy of this Notice to all Lessees within 10 days of your receipt of this Notice. Further, you must maintain a record, which identifies the Lessee(s) to whom you send a copy of this letter, the date you send this letter, and the Vehicle Identification Number(s) of the vehicle(s) that you have leased to that lessee. For purposes of this Notice, the term Lessor means: a person or entity that is the owner, as reflected on the vehicle's title, of any five or more leased vehicles (as defined in CFR Section 577.4), as of the date of notification by the manufacturer of the existence of a safety-related defect or non-compliance with a Federal Motor Vehicle Safety Standard in one or more of the leased motor vehicles.

**OWNER RECALL
RESPONSE CARD:**

The enclosed "Notice of Vehicle Recall" identifies your vehicle. If you no longer own the vehicle, please help us update our records by completing the "Vehicle Disposition Record" portion of the enclosed postage-free Notice of Mandatory Safety Campaign card and mailing it back to us.

**ASSISTANCE/
COMPLAINTS:**

If you need assistance, please contact:

Volvo Trucks North America
Regulatory Affairs Department,
P.O. Box 26115
Greensboro, NC 27402-6115
vtna.regulatoryaffairs@volvo.com

You may also submit complaints to the Administrator of the National Highway Traffic Safety Administration (1200 New Jersey Avenue, S.E., Washington DC 20590 or call the toll-free Auto Safety Hot Line at 1-888-327-4236 (TTY: 1-800-424-9153), or go to <http://www.safercar.gov>.

**PRE NOTIFICATION
REMEDIES:**

If you have previously paid for repairs as a result of this issue, you may be entitled to recovery of those expenses.

Submit copies of all documentation supporting your claim according to the rules specified in the "General Plan for Reimbursement of Pre-notification Remedies" provided in this mailing.

We regret any inconvenience this may cause to your operation, but hope you will appreciate our sincere efforts to demonstrate Volvo's commitment to provide our customers with the best possible product.

VOLVO TRUCKS NORTH AMERICA