

November 16, 2007

Dear Service Manager:

Honda Motor Co., Ltd, Inc., is announcing a safety recall campaign affecting all 1998–07 Civic GXs. In the event of a severe interior fire in the area of the rear seat, the CNG (compressed natural gas) fuel tank may be heated unevenly, preventing the pressure relief device from venting the contents of the tank as designed. This could result in a tank rupture, and even ejection of the tank from the vehicle. This situation was discovered after studying an act of arson on a Civic GX earlier this year. To minimize the risk of fuel tank rupture, we are conducting this campaign to install a fuel tank thermal insulator on all 1998–07 Civic GXs.

#### **Repair Strategy**

The repair is to install a fuel tank thermal insulator on the back of the rear seat-back. For repair and warranty information, refer to Service Bulletin 07-081, *Safety Recall: Fuel Tank Thermal Insulator*. All affected vehicles (including fleet-owned units) will be returned to Honda dealers for repair.

The fuel tank thermal insulator for each generation of the Civic GX is currently being manufactured. Enough parts to fully conduct this campaign will not be available until February or March 2008.

Some vehicles affected by this campaign may be in your new or used vehicle inventory. **To sell or lease one of these vehicles, you must give the buyer or lessee a copy of the full-page customer letter attached to the end of S/B 07-081.** To see if a vehicle is affected by this campaign, do a VIN status inquiry.

#### **Customer Notification**

During the week of November 26, owners of affected vehicles will be sent an initial notification of this campaign, explaining that parts are not yet available. As parts become available, owners will be sent a second notification.

#### **Parts Information**

A limited number of parts for retail vehicle owners and unsold vehicles in your inventory will start becoming available in late December 2007. These parts will be allocated based on affected vehicles sold by your dealership and those still in your inventory. Parts for open ordering will not be available until February or March 2008.

Sincerely,

**American Honda Motor Co., Inc.  
Honda Automobile Division**



## Safety Recall: Fuel Tank Thermal Insulator

### BACKGROUND

In the event of a severe interior fire in the area of the rear seat, the CNG (compressed natural gas) fuel tank may be heated unevenly, preventing the pressure relief device from venting the contents of the tank as designed. This could result in a tank rupture, and even ejection of the tank from the vehicle. This situation was discovered after studying an act of arson on a Civic GX earlier this year. To minimize the risk of fuel tank rupture, we are conducting a campaign to install a fuel tank thermal insulator on all 1998-07 Civic GXs.

### CUSTOMER NOTIFICATION

The fuel tank thermal insulator for each generation of the Civic GX is currently being manufactured. Enough parts to fully conduct this campaign will not be available until February or March 2008. All owners of affected vehicles will be sent an initial notification of this campaign, explaining that parts are not yet available. As parts become available, owners will be sent a second notification. Examples of both customer notifications are on pages 3 and 4 of this service bulletin.

Before working on a vehicle, you **must** verify its eligibility by checking at least one of these items:

- The customer has a **second** notification letter.
- The vehicle is shown as eligible on a VIN status inquiry.

In addition to these verification items, check for a punch mark **below** the first character of the engine compartment VIN. A punch mark in that location means this campaign has already been completed.

Some of the vehicles affected by this campaign may be in your new or used car inventory. **To sell or lease an affected vehicle in inventory, you must give the buyer or lessee a copy of the full-page customer letter attached to the end of this service bulletin.** To see if a vehicle in inventory is affected by this campaign, do a VIN status inquiry.

### CORRECTIVE ACTION

Install a fuel tank thermal insulator on the back of the rear seat-back.

### PARTS INFORMATION

Fuel Tank Thermal Insulator:

- 1998-00 Civic GX:  
P/N 06171-S1G-305, H/C 8861155
- 2001-05 Civic GX:  
P/N 06171-S5W-305, H/C 8861163
- 2006-07 Civic GX:  
P/N 06171-SNF-305, H/C 8859928

### REQUIRED SPECIAL TOOLS

Upholstery (Hog) Ring Pliers (commercially available)

### WARRANTY CLAIM INFORMATION

- Operation Number: 8530A2
- Flat Rate Time: 0.3 hour
- Failed Part: P/N 0671-SNF-305  
H/C 8859928
- Defect Code: 5NG00
- Symptom Code: Q6300
- Template ID: 1998-2000 Models - 07-081A  
2001-2005 Models - 07-081B  
2006-2007 Models - 07-081C
- Skill Level: Repair Technician

### REPAIR PROCEDURE

1. Remove the rear seat:
  - Refer to the Body section of the appropriate Civic GX Service Manual Supplement, or
  - Online, enter keywords **REAR SEAT**, and select **Rear Seat Removal/Installation (GX model)** from the list.
2. Place the rear seat-back upside down on a clean, flat surface.



- Position the thermal insulator on the back of the seat-back, towards the right passenger's side. Refer to the appropriate model-year illustration.

**NOTE:**

- Align the cut-out(s) and seam(s) on the top of the insulator with the hook(s) on the top of the seat-back.
- The pre-punched holes around the edge of the insulator should closely match up with the existing seat cover clips.
- Don't remove the existing seat cover clips.

**1998 - 2000 MODELS**

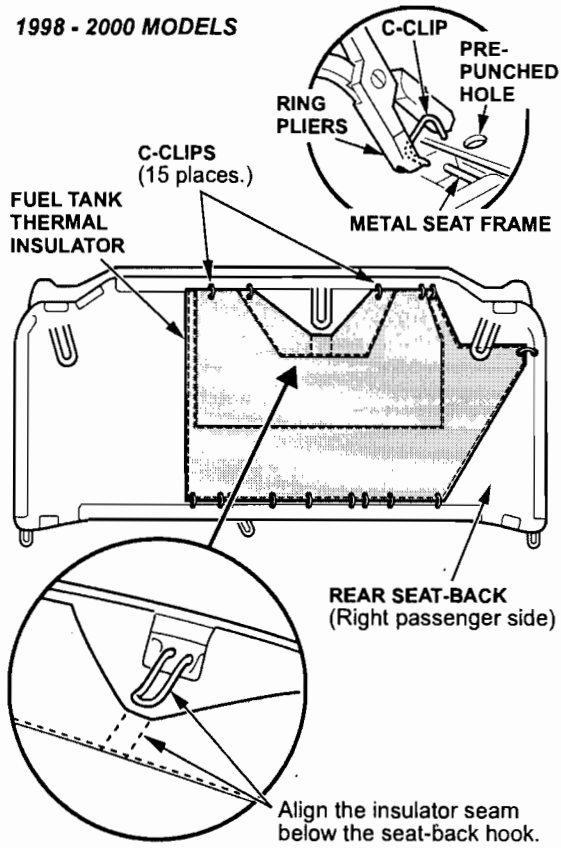

**2001 - 2005 MODELS**

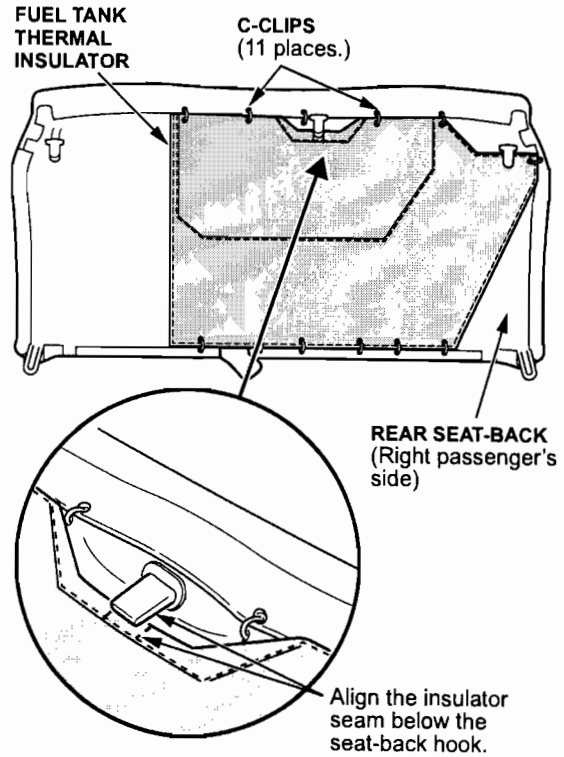

**2006 - 2007 MODELS**

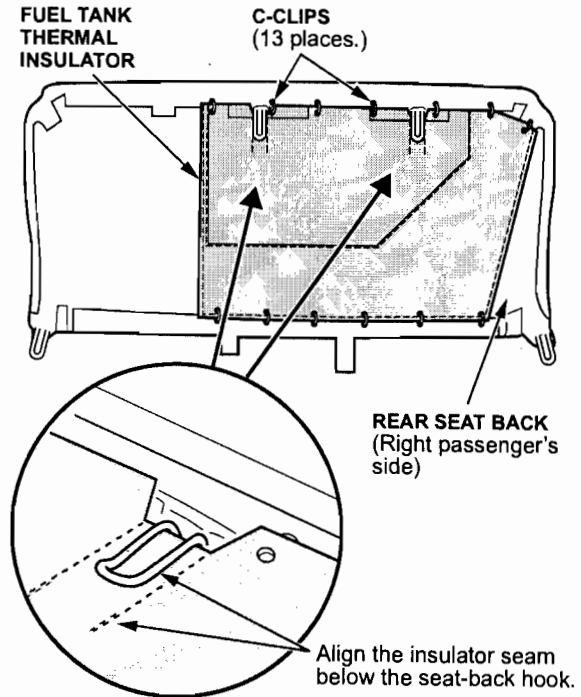

- Using upholstery (hog) ring pliers and C-clips, attach the insulator to the seat-back at each of the pre-punched holes. Make sure you attach each clip to the metal part of the seat frame. Don't remove the existing seat cover clips.

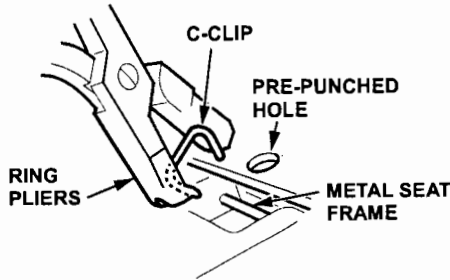

**NOTE:**

- 1998–00 models require 15 C-clips.
- 2001–05 models require 11 C-clips.
- 2006–07 models require 13 C-clips.

- Reinstall the rear seat.

**NOTE:**

- Before installation, make sure there are no twists or kinks in the seat belts.
- During installation, slip the seat belt buckles through their slits in the seat cushion.
- After installation, sit in the seat to make sure it's not loose or making noise.

- Center-punch a completion mark **below** the first character of the engine compartment VIN.

**NOTE:** On 2006–07 models, slide open the FRAME NUMBER door on the center cowl cover, and use a long punch to reach the VIN.

**1HGFA4XXXXXXXXXX**

Center-punch here.

*Example of Initial Customer Letter*

November 2007

**Safety Recall Campaign:  
Fuel Tank Heat Insulator**

Dear Civic GX Owner:

This notice is sent to you in accordance with the requirements of the National Traffic and Motor Vehicle Safety Act.

**What is the reason for this notice?**

Honda Motor Co., Ltd., has decided that a defect which relates to motor vehicle safety exists in 1998–2007 Civic GX compressed natural gas (CNG) vehicles. In the event of a severe interior fire in the area of the rear seat, the CNG tank may be heated unevenly, preventing the pressure relief device from venting the contents of the tank as designed. This could result in a tank rupture, and even ejection of the tank from the vehicle. This situation was discovered after studying an act of arson on a Civic GX earlier this year.

**What should you do?**

The dealer will install a heat insulator material to the back of the rear seat-back. This part is currently not available, but will be available soon. We will send another letter notifying you when to schedule an appointment to take your vehicle to an authorized Honda dealer to have the work done.

**What to do if you feel this notice is in error.**

Our records show that you are the current owner or lessee of a 1998–2007 Civic GX involved in this campaign. If this is not the case, or if the name/address information is not correct, please fill out and return the enclosed, postage-paid *Information Change Card*. We will then update our records.

**Lessor Information**

Federal law requires that any vehicle lessor receiving this recall notice must forward a copy of this notice to the lessee within 10 days.

**If you have questions.**

If you have any questions about this notice, or need assistance with locating a Honda dealer, please call Honda Automobile Customer Service at (800) 999-1009.

We apologize for any inconvenience this campaign may cause you.

Sincerely,

**American Honda Motor Co., Inc.  
Honda Automobile Division**

*Example of Second Customer Letter*  
(Various mail dates due to staggered parts availability.)

**Safety Recall Campaign:  
Fuel Tank Heat Insulator**

Dear Civic GX Owner:

This notice is sent to you in accordance with the requirements of the National Traffic and Motor Vehicle Safety Act.

**What is the reason for this notice?**

We recently sent you a recall notification involving 1998-2007 Civic GX compressed natural gas (CNG) vehicles. At that time, the part needed for your vehicle was not available. This notification is to inform you that the part is now available at your authorized Honda dealer.

Honda Motor Co., Ltd., has decided that a defect which relates to motor vehicle safety exists in 1998-2007 Civic GX compressed natural gas (CNG) vehicles. In the event of a severe interior fire in the area of the rear seat, the CNG tank may be heated unevenly, preventing the pressure relief device from venting the contents of the tank as designed. This could result in a tank rupture, and even ejection of the tank from the vehicle. This situation was discovered after studying an act of arson on a Civic GX.

**What should you do?**

Call any authorized Honda dealer and make an appointment to have your vehicle repaired. The dealer will install a heat insulator material on the back of the rear seat-back. This work will be done *free of charge*. Please plan to leave your vehicle at the dealer for half a day to allow the dealer flexibility in scheduling.

**Who to contact if you experience problems.**

If you are not satisfied with the service you receive from your Honda dealer, you may write to:

American Honda Motor Co., Inc.  
Honda Automobile Customer Service  
Mail Stop 500-2N-7A  
1919 Torrance Blvd.  
Torrance, CA 90501-2746

If you believe that American Honda or the dealer has failed or is unable to remedy the defect in your vehicle, without charge, within a reasonable period of time (60 days from the date you first contact the dealer for a repair appointment), you may submit a complaint to:

Administrator  
National Highway Traffic Safety Administration  
1200 New Jersey Avenue, S.E.  
Washington, DC 20590

You can also call the toll-free Safety Hotline at (888) 327-4236 (TTY [800] 424-9153), or go to <http://www.safercar.gov>.

**What to do if you feel this notice is in error.**

Our records show that you are the current owner or lessee of a 1998-2007 Civic GX involved in this campaign. If this is not the case, or if the name/address information is not correct, please fill out and return the enclosed, postage-paid *Information Change Card*. We will then update our records.

**Lessor Information**

Federal law requires that any vehicle lessor receiving this recall notice must forward a copy of this notice to the lessee within 10 days.

**If you have questions.**

If you have any questions about this notice, or need assistance with locating a Honda dealer, please call Honda Automobile Customer Service at (800) 999-1009.

We apologize for any inconvenience this campaign may cause you.

Sincerely,

**American Honda Motor Co., Inc.**  
**Honda Automobile Division**

November 2007

## **Safety Recall Campaign: Fuel Tank Heat Insulator**

Dear Civic GX Owner:

This notice is sent to you in accordance with the requirements of the National Traffic and Motor Vehicle Safety Act.

### **What is the reason for this notice?**

Honda Motor Co., Ltd., has decided that a defect which relates to motor vehicle safety exists in 1998–2007 Civic GX compressed natural gas (CNG) vehicles. In the event of a severe interior fire in the area of the rear seat, the CNG tank may be heated unevenly, preventing the pressure relief device from venting the contents of the tank as designed. This could result in a tank rupture, and even ejection of the tank from the vehicle. This situation was discovered after studying an act of arson on a Civic GX earlier this year.

### **What should you do?**

The dealer will install a heat insulator material to the back of the rear seat-back. This part is currently not available, but will be available soon. We will send another letter notifying you when to schedule an appointment to take your vehicle to an authorized Honda dealer to have the work done.

### **What to do if you feel this notice is in error.**

Our records show that you are the current owner or lessee of a 1998–2007 Civic GX involved in this campaign. If this is not the case, or if the name/address information is not correct, please fill out and return the enclosed, postage-paid *Information Change Card*. We will then update our records.

### **Lessor Information**

Federal law requires that any vehicle lessor receiving this recall notice must forward a copy of this notice to the lessee within 10 days.

### **If you have questions.**

If you have any questions about this notice, or need assistance with locating a Honda dealer, please call Honda Automobile Customer Service at (800) 999-1009.

We apologize for any inconvenience this campaign may cause you.

Sincerely,

**American Honda Motor Co., Inc.  
Honda Automobile Division**