

September 22, 2007

Dear Service Manager:

Honda Motor Co., Ltd., is announcing a safety recall campaign for certain 2006 Civic 4-door and Civic Hybrid vehicles. During vehicle assembly, the steering column telescopic mechanism may have been over-lubricated with silicone grease. Over time, some of this grease could form into oil droplets that drip onto the brake pedal position switch connector. If this happens, the brake pedal position switch may fail, resulting in no brake lights, and an increased risk of a rear end collision. In addition, a failed brake light switch could prevent the shift lever from moving out of Park (vehicles with A/T), or disable the auto-stop feature (Civic Hybrids).

Repair Strategy

The repair is to install a brake pedal position switch kit. The kit contains a new switch, switch attaching ring, switch connector, and switch boot. For repair, warranty, and affected VIN information, refer to Service Bulletin 07-061, *Safety Recall: Brake Pedal Position Switch May Fail*. Some of the vehicles affected by this campaign may be in your used car inventory. These vehicles must be repaired before they are sold or leased. To see if a vehicle is affected by this campaign, do a VIN status inquiry.

Customer Notification

Customers will be sent a notification of this campaign by the end the week.

Parts Information

This week, a quantity of kits equaling 35 percent of your sold vehicles will be allocated. Next week, additional kits will be available through the controlled parts ordering system.

Sincerely,

American Honda Motor Co., Inc.
Honda Automobile Division



Applies To: **2006 Civic 4-Door** – From VIN JHMFA1...6S000001 thru JHMFA1...6S013021
2006 Civic Hybrid – From VIN JHMFA3...6S000001 thru JHMFA3...6S023996

September 22, 2007

Safety Recall: Brake Pedal Position Switch May Fail

BACKGROUND

During vehicle assembly, the steering column telescopic mechanism may have been over-lubricated with silicone grease. Over time, some of this grease could form into oil droplets that drip onto the brake pedal position switch connector. If this happens, the brake pedal position switch may fail, resulting in no brake lights, and an increased risk of a rear-end collision. In addition, a failed brake light switch could prevent the shift lever from moving out of Park (vehicles with A/T), or disable the auto-stop feature (Civic Hybrids).

CUSTOMER NOTIFICATION

All owners of affected vehicles will be sent a notification of this campaign. An example of the customer notification is at the end of this service bulletin.

Not all vehicles within the VIN ranges are affected by this campaign. Before working on a vehicle, you **must** verify its eligibility by checking at least one of these items:

- The customer has a notification letter.
- The vehicle is shown as eligible on a VIN status inquiry.

In addition to these verification items, check for a punch mark below the first character of the engine compartment VIN. A punch mark in that location means this campaign has already been completed.

Some of the vehicles affected by this campaign may be in your used car inventory. **These vehicles must be repaired before they are sold or leased.** To see if a vehicle is affected by this campaign, do a VIN status inquiry.

CORRECTIVE ACTION

Install a brake pedal position switch kit.

PARTS INFORMATION

Brake Pedal Position Switch Kit:

P/N 06360-SNA-305, H/C 8827008

(Contains switch, switch attaching ring, switch connector, and switch boot.)

REQUIRED SPECIAL TOOLS

Terminal Pin Tool, P/N 07JAZ-002010A, H/C 3087731
 (From Terminal Pin Kit A,
 T/N 07JAZ-003000B, H/C 4733200)

REQUIRED MATERIALS

Electrical Tape: P/N 4100-0002, H/C 4452165
 (One roll repairs about 20 vehicles.)

WARRANTY CLAIM INFORMATION

Operation Number: 7261A2

Flat Rate Time: 0.6 hour

Failed Part: P/N 06360-SNA-305
 H/C 8827008

Defect Code: 5EY00

Symptom Code: Q5800

Template ID: 07-061A

Skill Level: Repair Technician

REPAIR PROCEDURE

1. Make sure you have the anti-theft code for the audio system or the navigation system (if equipped), then disconnect the negative cable from the 12 V battery.
2. Remove the driver's dashboard undercover.

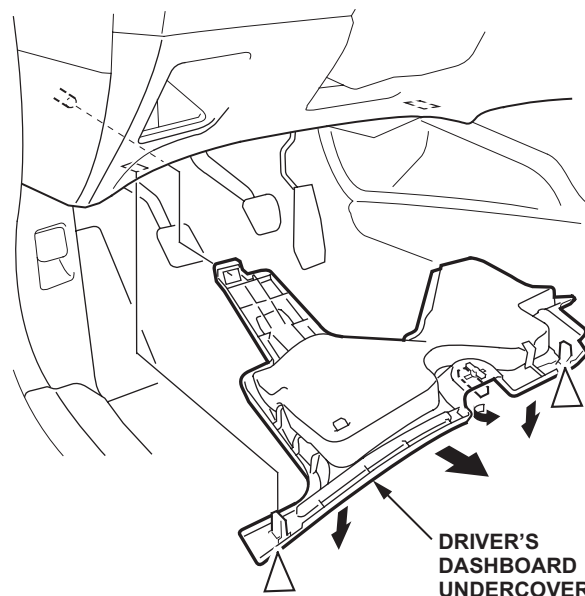

3. Remove the brake pedal position switch and its attaching ring:
 - Disconnect the switch connector.
 - Twist the switch counterclockwise 1/8 turn, then remove it. The switch will not be reused.
 - Pry the attaching ring out of the brake pedal bracket with a flat-tip screwdriver. The attaching ring will not be reused.

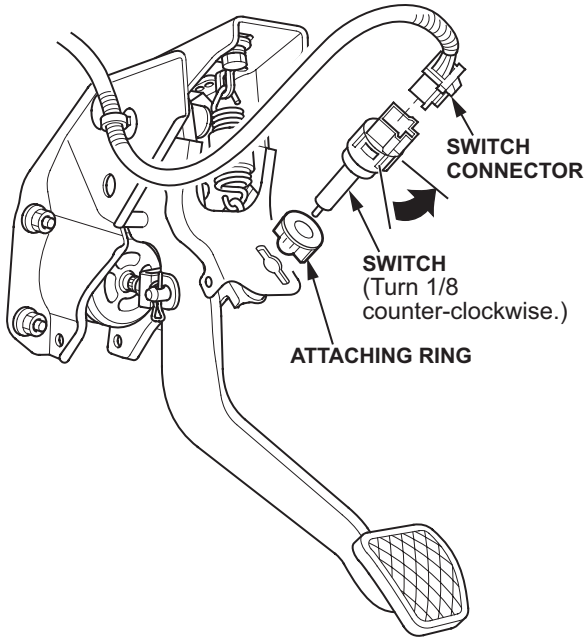

4. Note the terminal locations and wire colors in the switch connector. You'll need to install the terminals in the same locations in the new connector. Depending on the model, the connector has two or four terminals. The terminal locations are listed below.

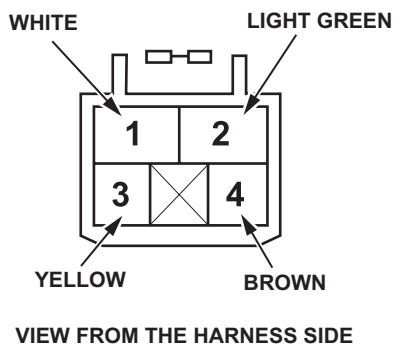

5. Using the pin tool, remove the connector lock from the side of the switch connector.

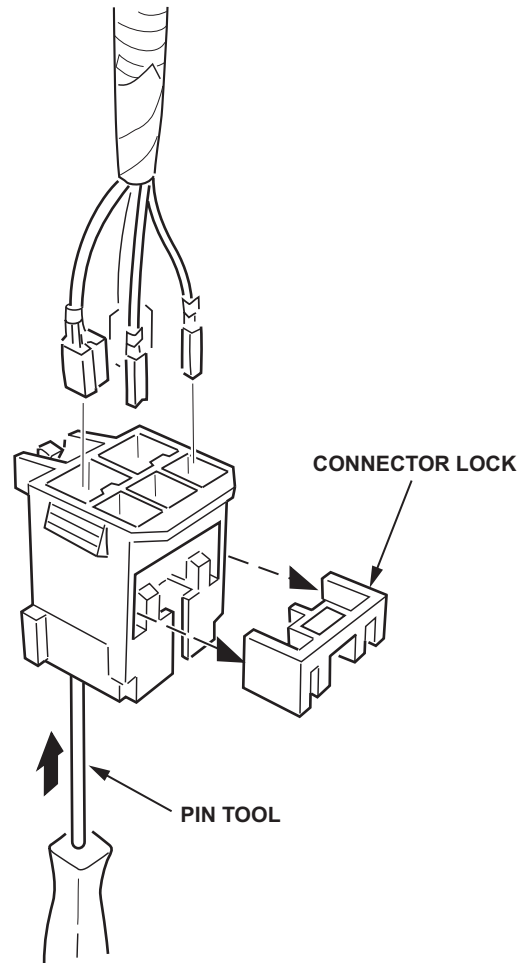

6. Using the pin tool, carefully remove the terminals from the back of the connector. The connector will not be reused.
7. Hold the terminals with a clean shop towel while cleaning them with compressed air.

8. Insert the terminals into the small end of the switch boot and out the large end.

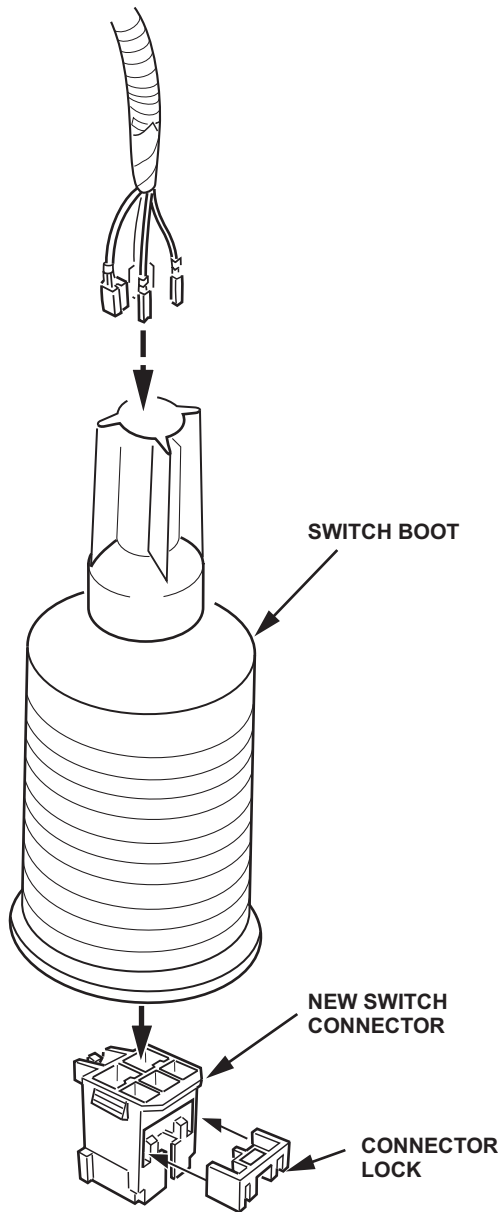

9. Remove the connector lock from the side of the new switch connector, then insert the terminals into their correct locations in the connector.

10. Pull the switch wires until the connector is in the small end of the switch boot. Using about 10 inches of electrical tape, tape the wires to the boot as shown.

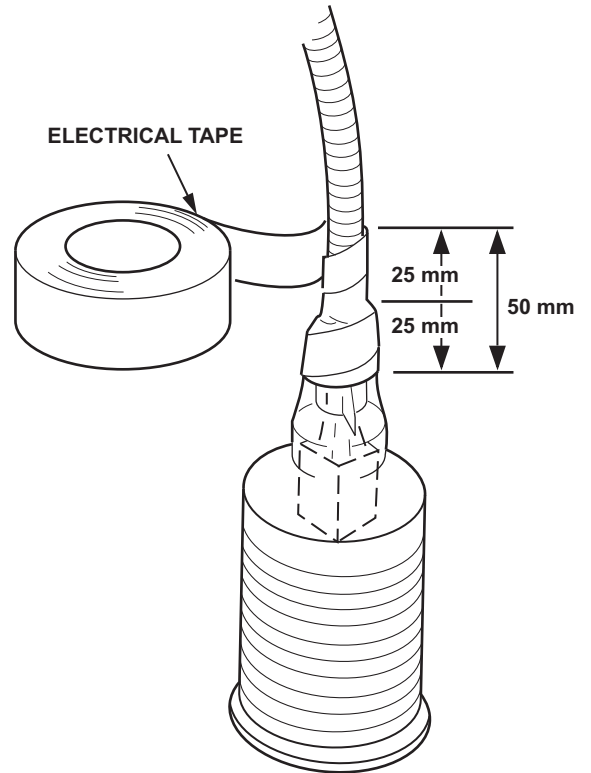

11. Install the new brake pedal position switch:

- Press a new switch attaching ring into the hole on the brake pedal bracket.
- Insert the switch into the attaching ring until the end of the switch touches the top of the brake pedal. Twist the switch clockwise, 1/8 turn, to lock it into position.

NOTE: When you lock the switch into position, the clearance for the pedal stop bracket automatically adjusts to 0.7 mm (0.028 in).

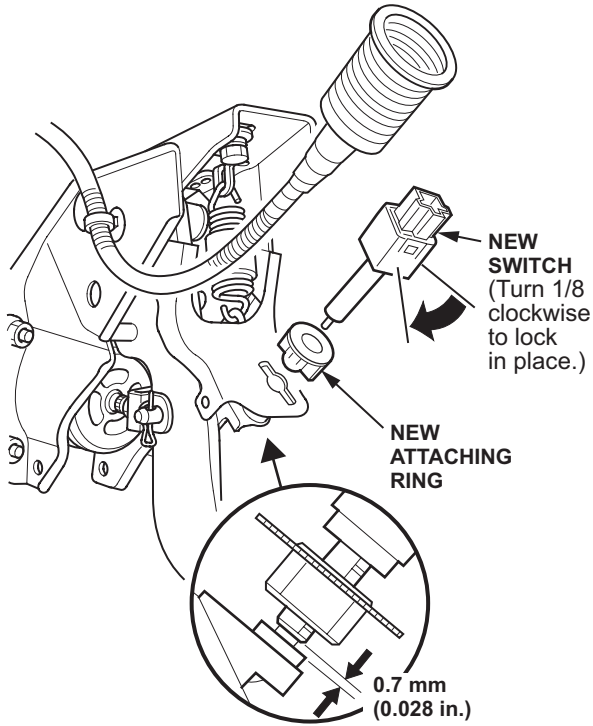

12. Slide the switch boot over the switch, and connect the switch connector.

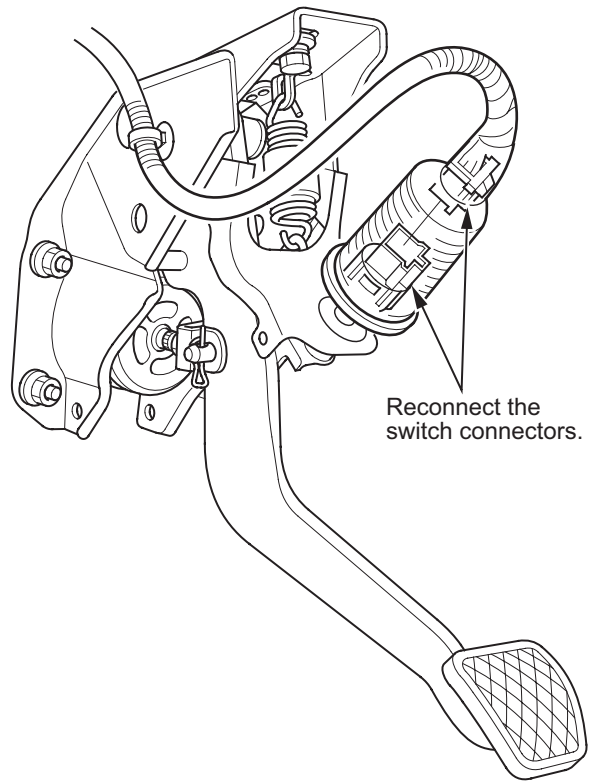

13. Reinstall the driver's dashboard undercover.

14. Reconnect the negative cable to the 12 V battery, then enter the audio anti-theft code or the navigation system code (if equipped).

15. Make sure the brake lights work, the transmission shifts out of P (A/T models), and the auto-stop feature works (Hybrid models).

16. Center-punch a completion mark below the first character of the engine compartment VIN:

- Slide open the FRAME NUMBER door on the center cowl cover.
- Use a long punch to reach the VIN.

JHMFA1XXXXXXXXXXXX

Center-punch here.

September 2007

Safety Recall: Brake Lights May Not Work

Dear Civic Sedan or Civic Hybrid Owner:

This notice is sent to you in accordance with the requirements of the National Traffic and Motor Vehicle Safety Act.

What is the reason for this notice?

Honda Motor Co., Ltd. has decided that a defect related to motor vehicle safety exists in certain 2006 model year Civics. During vehicle assembly, the telescopic steering column mechanism may have been over-lubricated with silicone grease. Over time, some of this extra grease may drip on the brake light switch and the brake light switch may fail. Failure may result in a loss of brake lights and an increased risk that your vehicle could be struck from the rear. In addition, a failed brake light switch could prevent shifting the transmission from the park position (applies to vehicles with an automatic transmission).

What should you do?

Call any authorized Honda dealer and make an appointment to have your vehicle repaired. The dealer will replace the brake light switch and install a protective cover over the switch. This work will be done *free of charge*. Please plan to leave your vehicle at the dealer for half a day to give the dealer some flexibility in scheduling.

Who to contact if you experience problems.

If you are not satisfied with the service you receive from your Honda dealer, you may write to:

American Honda Motor Co., Inc.
Honda Automobile Customer Service
Mail Stop 500-2N-7A
1919 Torrance Blvd.
Torrance, CA 90501-2746

If you believe that American Honda or the dealer has failed or is unable to remedy the defect in your vehicle, without charge, within a reasonable period of time (60 days from the date you first contact the dealer for a repair appointment), you may submit a complaint to:

Administrator
National Highway Traffic Safety Administration
1200 New Jersey Avenue, S.E.
Washington, DC 20590

You can also call the toll-free Safety Hotline at (888) 327-4236 [TTY (800) 424-9153], or go to www.safercar.gov.

What to do if you feel this notice is in error.

Our records show that you are the current owner or lessee of a 2006 Civic or Civic Hybrid involved in this campaign. If this is not the case, or if the name/address information is not correct, please fill out and return the enclosed, postage-paid *Information Change Card*. We will then update our records.

Lessor Information

Federal law requires that any vehicle lessor receiving this recall notice must forward a copy of this notice to the lessee within 10 days.

If you have questions.

If you have any questions about this notice, or need assistance with locating a Honda dealer, please call Honda Automobile Customer Service at (800) 999-1009.

We apologize for any inconvenience this campaign may cause you.

Sincerely,

American Honda Motor Co., Inc.
Honda Automobile Division