

**GM SERVICE AND PARTS OPERATIONS
DCS1855
URGENT DISTRIBUTE IMMEDIATELY**

Date: September 21, 2007
Subject: 07221 Product Safety Recall
ABS Operation
Models: 2008 Hummer H2
To: All Hummer Dealers
Attention: Service Manager, Parts Manager and Warranty Administrator

PRODUCT FIELD ACTION ANNOUNCEMENT

General Motors is announcing Product Safety Recall 07221 today. The total number of vehicles involved is 368. Please see the attached bulletin for details.

Mailing Information

Customer notification letter mailing will begin on September 27, 2007.

GM Vehicle Inquiry System (GMVIS)

GMVIS information will be available on September 20, 2007.

Service Information System (SI)

Bulletin 07079 is scheduled to be available on September 21, 2007.

Campaign Initiation Detail Report (CIDR)

The CIDR will be available in GM DealerWorld on September 20, 2007.

**PLEASE DOUBLE CLICK ON THE ICON BELOW
TO VIEW OR PRINT THE BULLETIN**

END OF MESSAGE
GM SERVICE AND PARTS OPERATIONS



Recall Bulletin



PRODUCT SAFETY RECALL

SUBJECT: ABS Operation

MODELS: 2008 HUMMER H2

CONDITION

General Motors has decided that a defect, which relates to motor vehicle safety, exists in **certain** 2008 HUMMER H2 vehicles. Certain wires in the ABS wheel speed sensor wiring harness may be reversed. This condition could result in increased stopping distance under certain circumstances. If vehicle stopping distance is increased, a crash could occur.

CORRECTION

Depending on the VIN, dealers are to correct the ABS wheel speed sensor wiring if required, reprogram the brake control module, or both.

VEHICLES INVOLVED

Involved vehicles, and their required repairs, are listed below.

<u>VIN</u>	<u>Required Service</u>	<u>VIN</u>	<u>Required Service</u>	<u>VIN</u>	<u>Required Service</u>
8H100108	Reprogram Only	8H100132	Both Procedures	8H100151	Both Procedures
8H100111	Both Procedures	8H100133	Wire Repair Only	8H100154	Both Procedures
8H100112	Both Procedures	8H100134	Both Procedures	8H100155	Both Procedures
8H100113	Both Procedures	8H100135	Both Procedures	8H100156	Both Procedures
8H100114	Both Procedures	8H100136	Both Procedures	8H100159	Wire Repair Only
8H100115	Both Procedures	8H100137	Wire Repair Only	8H100160	Both Procedures
8H100116	Both Procedures	8H100138	Both Procedures	8H100162	Both Procedures
8H100118	Both Procedures	8H100139	Both Procedures	8H100163	Wire Repair Only
8H100121	Both Procedures	8H100140	Both Procedures	8H100164	Both Procedures
8H100122	Both Procedures	8H100141	Both Procedures	8H100165	Both Procedures
8H100123	Both Procedures	8H100142	Both Procedures	8H100166	Both Procedures
8H100126	Both Procedures	8H100145	Both Procedures	8H100167	Both Procedures
8H100127	Both Procedures	8H100146	Both Procedures	8H100170	Both Procedures
8H100128	Both Procedures	8H100147	Both Procedures	8H100171	Both Procedures
8H100130	Both Procedures	8H100149	Both Procedures	8H100172	Both Procedures
8H100131	Both Procedures	8H100150	Both Procedures	8H100173	Both Procedures

8H100174	Both Procedures	8H100242	Both Procedures	8H100307	Both Procedures
8H100175	Both Procedures	8H100243	Both Procedures	8H100308	Both Procedures
8H100177	Both Procedures	8H100245	Both Procedures	8H100310	Both Procedures
8H100179	Both Procedures	8H100246	Both Procedures	8H100312	Both Procedures
8H100180	Wire Repair Only	8H100247	Both Procedures	8H100313	Both Procedures
8H100181	Both Procedures	8H100248	Both Procedures	8H100314	Both Procedures
8H100182	Both Procedures	8H100250	Both Procedures	8H100315	Both Procedures
8H100183	Both Procedures	8H100252	Both Procedures	8H100316	Both Procedures
8H100184	Both Procedures	8H100253	Both Procedures	8H100317	Both Procedures
8H100185	Wire Repair Only	8H100254	Both Procedures	8H100318	Both Procedures
8H100186	Both Procedures	8H100255	Both Procedures	8H100319	Both Procedures
8H100188	Both Procedures	8H100257	Both Procedures	8H100321	Both Procedures
8H100189	Both Procedures	8H100258	Both Procedures	8H100324	Both Procedures
8H100190	Both Procedures	8H100259	Both Procedures	8H100325	Both Procedures
8H100191	Both Procedures	8H100260	Both Procedures	8H100327	Both Procedures
8H100192	Both Procedures	8H100261	Both Procedures	8H100328	Both Procedures
8H100193	Both Procedures	8H100262	Both Procedures	8H100329	Both Procedures
8H100194	Both Procedures	8H100264	Both Procedures	8H100330	Both Procedures
8H100195	Both Procedures	8H100265	Both Procedures	8H100332	Both Procedures
8H100197	Wire Repair Only	8H100267	Both Procedures	8H100333	Both Procedures
8H100198	Both Procedures	8H100269	Both Procedures	8H100334	Both Procedures
8H100199	Wire Repair Only	8H100270	Both Procedures	8H100336	Both Procedures
8H100200	Both Procedures	8H100271	Wire Repair Only	8H100337	Both Procedures
8H100201	Both Procedures	8H100272	Both Procedures	8H100338	Both Procedures
8H100202	Both Procedures	8H100273	Both Procedures	8H100339	Both Procedures
8H100203	Both Procedures	8H100274	Both Procedures	8H100340	Both Procedures
8H100204	Both Procedures	8H100275	Both Procedures	8H100341	Both Procedures
8H100205	Both Procedures	8H100276	Both Procedures	8H100342	Both Procedures
8H100208	Both Procedures	8H100278	Both Procedures	8H100343	Both Procedures
8H100210	Both Procedures	8H100279	Both Procedures	8H100344	Wire Repair Only
8H100211	Both Procedures	8H100280	Both Procedures	8H100347	Wire Repair Only
8H100212	Both Procedures	8H100281	Both Procedures	8H100349	Both Procedures
8H100213	Both Procedures	8H100282	Both Procedures	8H100351	Both Procedures
8H100214	Both Procedures	8H100284	Both Procedures	8H100353	Both Procedures
8H100217	Both Procedures	8H100285	Both Procedures	8H100355	Both Procedures
8H100218	Both Procedures	8H100286	Both Procedures	8H100356	Both Procedures
8H100219	Wire Repair Only	8H100287	Both Procedures	8H100357	Both Procedures
8H100220	Both Procedures	8H100288	Both Procedures	8H100361	Both Procedures
8H100221	Both Procedures	8H100289	Wire Repair Only	8H100364	Wire Repair Only
8H100223	Both Procedures	8H100292	Wire Repair Only	8H100366	Both Procedures
8H100224	Both Procedures	8H100293	Both Procedures	8H100367	Both Procedures
8H100226	Both Procedures	8H100294	Both Procedures	8H100368	Both Procedures
8H100227	Both Procedures	8H100295	Wire Repair Only	8H100369	Both Procedures
8H100232	Both Procedures	8H100297	Both Procedures	8H100370	Both Procedures
8H100233	Both Procedures	8H100298	Both Procedures	8H100371	Both Procedures
8H100234	Both Procedures	8H100299	Both Procedures	8H100372	Both Procedures
8H100235	Both Procedures	8H100300	Both Procedures	8H100374	Both Procedures
8H100237	Both Procedures	8H100302	Both Procedures	8H100375	Both Procedures
8H100238	Both Procedures	8H100303	Wire Repair Only	8H100376	Both Procedures
8H100239	Both Procedures	8H100304	Both Procedures	8H100377	Both Procedures
8H100240	Both Procedures	8H100305	Both Procedures	8H100378	Both Procedures
8H100241	Both Procedures	8H100306	Both Procedures	8H100380	Both Procedures

8H100383	Both Procedures	8H100483	Both Procedures	8H100590	Both Procedures
8H100385	Both Procedures	8H100486	Reprogram Only	8H100591	Both Procedures
8H100386	Both Procedures	8H100487	Both Procedures	8H100593	Both Procedures
8H100388	Both Procedures	8H100488	Both Procedures	8H100594	Both Procedures
8H100392	Both Procedures	8H100491	Both Procedures	8H100595	Both Procedures
8H100393	Both Procedures	8H100496	Both Procedures	8H100596	Both Procedures
8H100394	Wire Repair Only	8H100497	Both Procedures	8H100597	Both Procedures
8H100395	Both Procedures	8H100499	Wire Repair Only	8H100603	Reprogram Only
8H100397	Both Procedures	8H100501	Both Procedures	8H100607	Both Procedures
8H100398	Both Procedures	8H100502	Both Procedures	8H100613	Both Procedures
8H100400	Wire Repair Only	8H100503	Both Procedures	8H100617	Both Procedures
8H100405	Both Procedures	8H100505	Wire Repair Only	8H100619	Wire Repair Only
8H100406	Both Procedures	8H100506	Both Procedures	8H100623	Both Procedures
8H100408	Wire Repair Only	8H100508	Both Procedures	8H100629	Both Procedures
8H100410	Both Procedures	8H100509	Both Procedures	8H100633	Both Procedures
8H100412	Both Procedures	8H100510	Both Procedures	8H100637	Both Procedures
8H100414	Both Procedures	8H100511	Both Procedures	8H100638	Both Procedures
8H100415	Both Procedures	8H100512	Both Procedures	8H100639	Both Procedures
8H100417	Both Procedures	8H100513	Both Procedures	8H100641	Both Procedures
8H100418	Both Procedures	8H100515	Both Procedures	8H100642	Both Procedures
8H100424	Both Procedures	8H100519	Reprogram Only	8H100644	Both Procedures
8H100425	Both Procedures	8H100520	Both Procedures	8H100647	Both Procedures
8H100426	Both Procedures	8H100526	Both Procedures	8H100661	Both Procedures
8H100427	Both Procedures	8H100528	Both Procedures	8H100664	Both Procedures
8H100431	Both Procedures	8H100530	Both Procedures	8H100667	Both Procedures
8H100432	Both Procedures	8H100537	Both Procedures	8H100668	Both Procedures
8H100436	Both Procedures	8H100538	Both Procedures	8H100674	Both Procedures
8H100439	Both Procedures	8H100542	Both Procedures	8H100678	Both Procedures
8H100440	Both Procedures	8H100543	Both Procedures	8H100681	Wire Repair Only
8H100444	Both Procedures	8H100544	Wire Repair Only	8H100682	Both Procedures
8H100445	Both Procedures	8H100547	Both Procedures	8H100689	Both Procedures
8H100448	Both Procedures	8H100549	Both Procedures	8H100690	Both Procedures
8H100449	Both Procedures	8H100551	Both Procedures	8H100694	Wire Repair Only
8H100451	Wire Repair Only	8H100553	Both Procedures	8H100696	Both Procedures
8H100454	Both Procedures	8H100555	Both Procedures	8H100698	Wire Repair Only
8H100455	Both Procedures	8H100556	Both Procedures	8H100707	Both Procedures
8H100456	Both Procedures	8H100557	Both Procedures	8H100708	Both Procedures
8H100457	Wire Repair Only	8H100560	Both Procedures	8H100714	Wire Repair Only
8H100458	Both Procedures	8H100562	Wire Repair Only	8H100721	Both Procedures
8H100462	Both Procedures	8H100563	Both Procedures	8H100727	Both Procedures
8H100463	Both Procedures	8H100565	Both Procedures	8H100733	Reprogram Only
8H100465	Both Procedures	8H100566	Wire Repair Only	8H100739	Both Procedures
8H100466	Both Procedures	8H100568	Both Procedures	8H100748	Both Procedures
8H100468	Both Procedures	8H100569	Wire Repair Only	8H100752	Wire Repair Only
8H100469	Wire Repair Only	8H100571	Reprogram Only	8H100757	Both Procedures
8H100472	Both Procedures	8H100574	Both Procedures	8H100777	Both Procedures
8H100473	Both Procedures	8H100576	Both Procedures	8H100788	Both Procedures
8H100475	Wire Repair Only	8H100579	Wire Repair Only	8H100793	Reprogram Only
8H100478	Both Procedures	8H100581	Wire Repair Only	8H100798	Wire Repair Only
8H100479	Both Procedures	8H100583	Both Procedures	8H100801	Both Procedures
8H100480	Both Procedures	8H100584	Both Procedures	8H100811	Both Procedures
8H100481	Both Procedures	8H100585	Both Procedures	8H100823	Both Procedures

8H100824	Both Procedures	8H100939	Reprogram Only	8H101133	Wire Repair Only
8H100876	Both Procedures	8H100955	Reprogram Only	8H101143	Wire Repair Only
8H100926	Reprogram Only	8H100967	Wire Repair Only		

Important: Dealers are to confirm vehicle eligibility prior to beginning repairs by using the GM Vehicle Inquiry System (GMVIS).

For dealers/ with involved vehicles, a listing with involved vehicles containing the complete vehicle identification number, customer name, and address information has been prepared and will be provided through the applicable system listed below. Dealers will not have a report available if they have no involved vehicles currently assigned.

- US dealers - GM DealerWorld Recall Information
- Canadian dealers - GMInfoNet Recall Reports

The listing may contain customer names and addresses obtained from Motor Vehicle Registration Records. The use of such motor vehicle registration data for any purpose other than follow-up necessary to complete this recall is a violation of law in several states/provinces/countries. Accordingly, you are urged to limit the use of this report to the follow-up necessary to complete this recall.

PARTS INFORMATION

No parts are required for this recall.

SERVICE PROCEDURE

Important: See the Vehicles Involved section of this bulletin to determine the service required for each individual vehicle.

Wire Repair - (use only if applicable – see the Vehicles Involved section of this bulletin)

1. Hook up the Tech 2 to the vehicle.
 - 1.1 Capture the DTCs, if required.
 - 1.2 Clear the DTCs, if required.
 - 1.3 Ensure that there are no DTCs present before proceeding to Step 2.
2. Lift and support the vehicle. Refer to *Lifting and Jacking the Vehicle* in SI.



2006005



2006006

3. Disconnect the left front and left rear wheel speed sensor wires. The front wheel speed sensor wire can be disconnected at the connection near the upper control arm pivot point on the frame (1). The left rear wheel speed sensor wire can be disconnected at the wheel speed sensor on the end of the axle housing near the wheel (2).
4. Using the Tech 2, determine if the DTC set corresponds to the wheel speed sensor that was disconnected.
 - If the DTC set corresponds to the sensor disconnected, proceed to Step 11.
 - If the DTC set does NOT correspond to the sensor disconnected, then the left and right wheel speed sensor wires are cross-wired. Lower the vehicle. Refer to the *EBCM Wiring Schematic* and Step 5.

EBCM Wiring Schematic

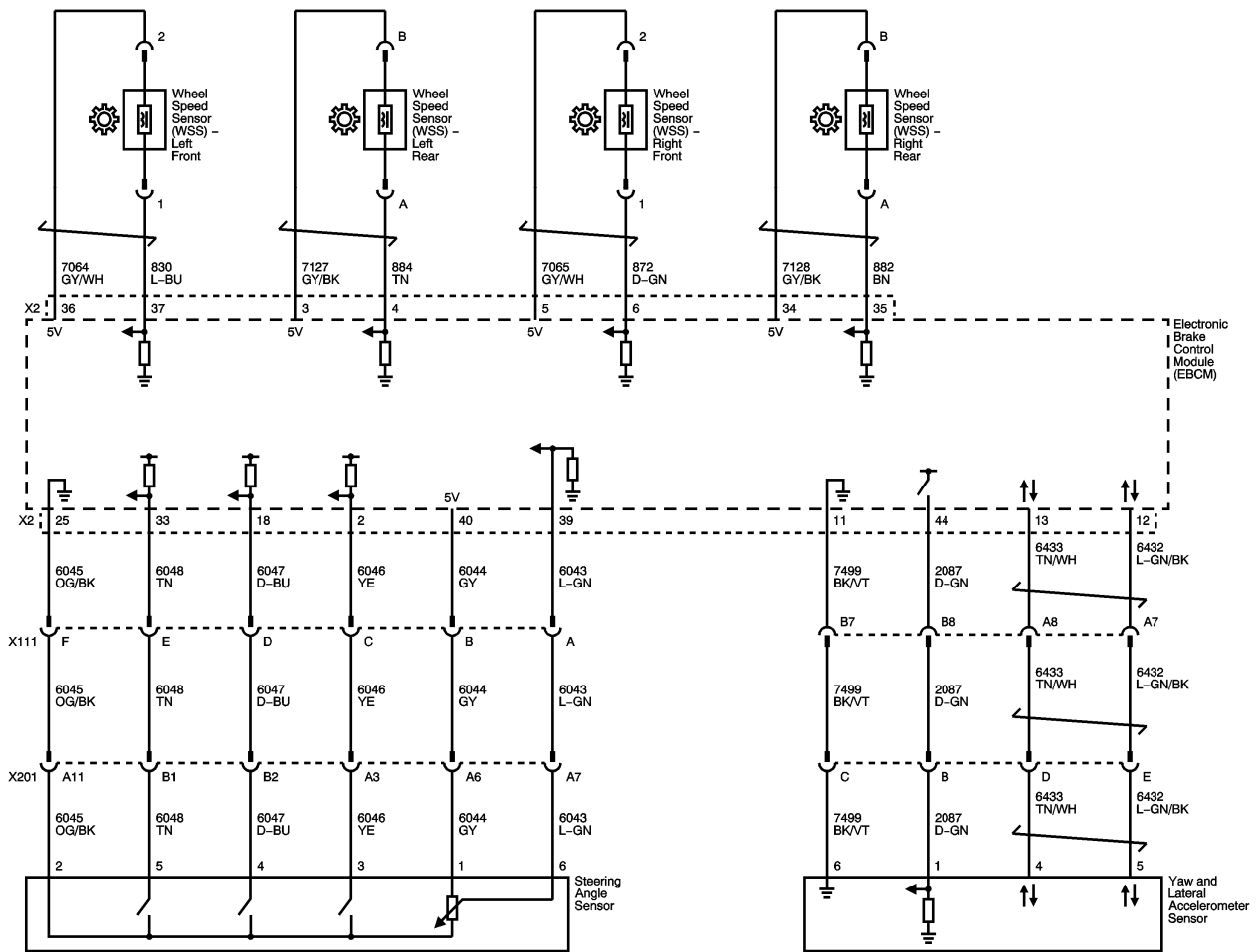

2006007

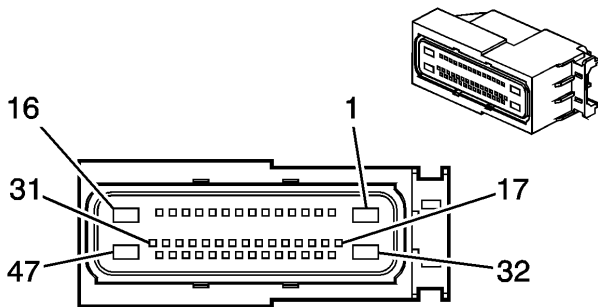

1858233



2006008

5. Locate the electronic brake control module connector (EBCM).



2006010

6. Press the release tab and remove the under hood fuse block cover.



2006011

7. Press and hold the release tab while lifting to remove the connector from the EBCM, and fully open the connector to access the wires.



2006012

8. Remove the white dress cover from the connector.
9. Refer to the *EBCM Wiring Schematic* to locate the correct connector cavities and terminal wire colors for the cross-wired wheel speed sensors. Note: Wires into cavities 6 and 37 may be switched (front wheels) or wires into cavities 4 and 35 may be switched (rear wheels).



2006015



2006016

10. Remove one of the cross-wired terminal wires from its connector cavity and install this terminal wire in the correct location of the connector. Do likewise with the other cross-wired terminal wire. The two wires should now be located in each other's original pin locations in the connector.
11. Connect the wheel speed sensors and clear the DTCs. Ensure that there are no DTCs set.
12. Lower the vehicle.

Reprogram Procedure - (use only if applicable – see the Vehicles Involved section of this bulletin)

Tech 2 Legacy or J2534 Pass-Thru Programming Method for the EBCM

Important: If Tech 2 Legacy or J2534 Pass-Thru programming fails, call Techline Customer Support Center (TCSC) at 1-800-828-6860 (English) or 1-800-503-3222 (French). A “Candi” module is necessary.

CALIBRATION INFORMATION

Do not attempt to order the calibration number from GMSP0. The calibration numbers required for this service procedure are programmed into control modules via a Techline Tech 2[®] scan tool and TIS 2 Web with the calibration update. Use **TIS 2 Web version 9.0 for 2007** (available on 09/03/07). If you cannot access the calibration, call the Techline Customer Support Center at 1-800-828-6860 (English) or 1-800-503-3222 (French) and it will be provided.

Notice: Before reprogramming, please check the battery condition to prevent a reprogramming error of any of the modules due to battery discharge. Battery voltage must be between 12 and 16 volts during reprogramming. If the vehicle battery is not fully charged, use jumper cables from an additional battery. Be sure to turn off or disable any system that may put a load on the battery, such as automatic headlamps, daytime running lights, interior lights, heating, ventilation, and air conditioning (HVAC) system, radio, engine cooling fan, etc. A programming failure or control module damage may occur if battery voltage guidelines are not observed.

The ignition switch must be in the proper position. The Service Programming System (SPS) application prompts you to turn ON the ignition, with the engine OFF. DO NOT change the position of the ignition switch during the programming procedure, unless instructed to do so.

Make certain all tool connections are secure, including the following components and circuits:

- The RS-232 communication cable port
- The connection at the data link connector (DLC)
- The voltage supply circuits

DO NOT disturb the tool harnesses while programming. If an interruption occurs during the programming procedure, programming failure or control module damage may occur.

DO NOT turn OFF the ignition if the programming procedure is interrupted or unsuccessful. Ensure that all control module and DLC connections are secure and the TIS terminal operating software is up to date.

1. Verify that there is a battery charge of 12 to 16 volts. The battery must be able to maintain a charge during programming. Use an additional jump battery if necessary. Only use approved Midtronics charger or Jumper Packs, etc. to maintain proper battery voltage during programming.
2. Reprogram the electronic brake control module (EBCM). Refer to SI and Service Programming System (SPS) documentation for EBCM programming instructions, if required.

COURTESY TRANSPORTATION

The General Motors Courtesy Transportation Program is intended to minimize customer inconvenience when a vehicle requires a repair that is covered by the New Vehicle Limited Warranty. The availability of courtesy transportation to customers whose vehicles are within the warranty coverage period and involved in a product recall is very important in maintaining customer satisfaction. Dealers are to ensure that these customers understand that shuttle service or some other form of courtesy transportation is available and will be provided at no charge. Dealers should refer to the General Motors Service Policies and Procedures Manual for courtesy transportation guidelines.

CLAIM INFORMATION

Submit a Product Recall Claim with the information indicated below:

REPAIR PERFORMED	PART COUNT	PART NO.	PARTS ALLOW	CC-FC	LABOR OP	LABOR HOURS
Wheel Speed Sensor Diagnostic Test Only - No Wire Repair	N/A	N/A	N/A	MA-96	V1699	0.4
Wheel Speed Sensor Diagnostic Test Only - Wire Repair Req'd.	N/A	N/A	N/A	MA-96	V1700	0.8
Wheel Speed Sensor Diagnostic Test & EBCM Reprogramming (No Wire Repair Req'd)	N/A	N/A	N/A	MA-96	V1701	0.8
Wheel Speed Sensor Diagnostic Test, Wire Repair, & EBCM Reprogramming	N/A	N/A	N/A	MA-96	V1702	1.2
EBCM Reprogramming Only (Wheel Speed Sensor Diagnostic Test Not Required)	N/A	N/A	N/A	MA-96	V1703	0.4
Courtesy Transportation for vehicles within the New Vehicle Limited Warranty (US & Canadian GM Dealers)	N/A	N/A	N/A	MA-96	*	N/A

- * Submit courtesy transportation using normal labor operations for courtesy transportation as indicated in the GM Service Policies and Procedures Manual for vehicles within the New Vehicle Limited Warranty.

Refer to the General Motors WINS Claims Processing Manual for details on Product Recall Claim Submission.

CUSTOMER NOTIFICATION

General Motors will notify customers of this recall on their vehicle (see copy of customer letter included with this bulletin).

DEALER RECALL RESPONSIBILITY – For US (US States, Territories, and Possessions)

The US National Traffic and Motor Vehicle Safety Act provides that each vehicle that is subject to a recall of this type must be adequately repaired within a reasonable time after the customer has tendered it for repair. A failure to repair within sixty days after tender of a vehicle is prima facie evidence of failure to repair within a reasonable time. If the condition is not adequately repaired within a reasonable time, the customer may be entitled to an identical or reasonably equivalent vehicle at no charge or to a refund of the purchase price less a reasonable allowance for depreciation. To avoid having to provide these burdensome remedies, every effort must be made to promptly schedule an appointment with each customer and to repair their vehicle as soon as possible. In the recall notification letters, customers are told how to contact the US National Highway Traffic Safety Administration if the recall is not completed within a reasonable time.

DEALER RECALL RESPONSIBILITY – All

All unsold new vehicles in dealers' possession and subject to this recall must be held and inspected/repaired per the service procedure of this recall bulletin before customers take possession of these vehicles.

Dealers are to service all vehicles subject to this recall at no charge to customers, regardless of mileage, age of vehicle, or ownership, from this time forward.

Customers who have recently purchased vehicles sold from your vehicle inventory, and for which there is no customer information indicated on the dealer listing, are to be contacted by the dealer. Arrangements are to be made to make the required correction according to the instructions contained in this bulletin. A copy of the customer letter is provided in this bulletin for your use in contacting customers. Recall follow-up cards should not be used for this purpose, since the customer may not as yet have received the notification letter.

In summary, whenever a vehicle subject to this recall enters your vehicle inventory, or is in your dealership for service in the future, you must take the steps necessary to be sure the recall correction has been made before selling or releasing the vehicle.



September 2007

Dear General Motors Customer:

This notice is sent to you in accordance with the requirements of the National Traffic and Motor Vehicle Safety Act.

General Motors has decided that a defect that relates to motor vehicle safety exists in certain 2008 HUMMER H2 vehicles. As a result, GM is conducting a safety recall. We apologize for this inconvenience. However, we are concerned about your safety and continued satisfaction with our products.

I M P O R T A N T

- Your vehicle is involved in safety recall 07221.
- Schedule an appointment with your GM dealer.
- This service will be performed for you at **no charge**.

Why is your vehicle being recalled?

Certain wires in the ABS wheel speed sensor wiring harness may be reversed. This condition could result in increased stopping distance under certain circumstances. If vehicle stopping distance is increased, a crash could occur.

What will we do?

Your GM dealer will correct the ABS wheel speed sensor wiring, if required, and in some cases, reprogram the brake control module. This service will be performed for you at **no charge**. Because of service scheduling requirements, it is likely that your dealer will need your vehicle longer than the actual service correction time of approximately 20 minutes to 1 hour and 15 minutes, depending on the service required.

If your vehicle is within the New Vehicle Limited Warranty your dealer may provide you with shuttle service or some other form of courtesy transportation while your vehicle is at the dealership for this repair. Please refer to your Owner's Manual and your dealer for details on courtesy transportation.

What should you do?

You should contact your GM dealer to arrange a service appointment as soon as possible. Bring the enclosed customer reply form with you when you visit your dealer. The form identifies the repairs required. If you no longer own this vehicle, please let us know by completing the form and mailing it back to us.

Do you have questions?

If you have questions or concerns that your dealer is unable to resolve, please contact the appropriate Customer Assistance Center at the number listed below. More information about this recall can be found at the Owner Center at MyGMLink, <http://www.gm.com/recall>

Division	Number	Text Telephones (TTY)
Hummer	1-866-964-8663	
Guam	1-671-648-8650	
Puerto Rico – English	1-800-496-9992	
Puerto Rico – Español	1-800-496-9993	
Virgin Islands	1-800-496-9994	

If after contacting your dealer and the Customer Assistance Center, you are still not satisfied we have done our best to remedy this condition without charge and within a reasonable time, you may wish to write the Administrator, National Highway Traffic Safety Administration, 1200 New Jersey Avenue, SE, Washington DC 20590, or call the toll-free Vehicle Safety Hotline at 1.888.327.4236 (TTY 1.800.424.9153), or go to <http://www.safercar.gov>.

Federal regulation requires that any vehicle lessor receiving this recall notice must forward a copy of this notice to the lessee within ten days.

Scott Lawson
General Director,
Customer and Relationship Services

Enclosure
07221