



MACK TRUCKS, INC.
2100 MACK BOULEVARD
P.O. BOX M
ALLENTOWN, PA 18105-5000

May 1, 2008

TO: DISTRIBUTOR PRINCIPALS
SERVICE MANAGERS

SUBJECT: Vehicle Safety Recall - SC0335
SR7™ Spring Brake Modulating Valve & Parker Check Valve

On certain Mack model vehicles manufactured from November 2005 through May 2007, Bendix has determined that a manufacturing defect exists in the internal rubber check valves inside the SR-7™ spring brake modulating valve. The internal check valve rubber can become deformed over time and can potentially result in the check valve not properly seating. The resulting leakage can cause a delay in the application of the spring brakes (i.e. park brakes) when the driver applies the park brakes.

Additionally, these vehicles may contain a defective Parker check valve. After prolonged use of the Parker single check valve, the valve body retainer may become excessively worn and eventually break apart. Pieces of the Parker single check valve can become lodged inside the SR-7 spring brake modulating valve, potentially causing either leakage out of the SR-7 valve or preventing air from properly exhausting from the SR-7 valve. This condition can cause a delay in the application of the spring brakes (i.e. park brakes) when the driver applies the park brakes, or the spring brakes may not fully release, or there may be a loss of isolation between the primary and secondary circuits.

Approximately 24,439 are involved in this safety recall.

A copy of the service bulletin covering the repair instructions and procedures is enclosed.

It is important that preparation be made immediately to assure prompt inspection and/or correction of all vehicles involved. The National Traffic and Motor Vehicle Safety Act and Canadian Motor Vehicle Safety Act requires dealers to insure that all new and used vehicles are free of safety defects and comply with all relevant safety standards at the time of delivery to the consumer. All Safety Recalls, which affect new or used inventory, must be performed before the vehicle is sold or leased. Please refer to Service Operations Service Letter #SL-004-001 dated 11/19/92 regarding the aforementioned amendment.

Please note that Dealers are responsible for performing the recall on all vehicles subject to the recall at no charge to the owner regardless of mileage, age of vehicle, or ownership from this time forward. Additionally, the National Traffic and Motor Vehicle Safety Act requires that the owner's vehicle(s) be corrected within a reasonable time after parts are available to the Dealer. The law states that failure to repair a vehicle within (60) days after tender for repair shall be a prima facie evidence of unreasonable time. However, circumstances of a particular situation may reduce the sixty (60) day period. If the vehicle is not repaired within a reasonable time, the vehicle owner may be entitled, without charge, to a reasonable equivalent vehicle or refund of the purchase price, less reasonable allowances for depreciation.

Please use the enclosed Notice of Mandatory Safety Campaign card(s) to report sold or transferred trucks. Make sure these cards are returned to us and not directly to the customer or to another dealer. A notice of the recall will be mailed to all identified registrants of affected vehicles. To avoid warranty denial of your claim for reimbursement of expenses connected with this recall, first, make sure the truck presented for the recall has the recall authorization loaded in eWarranty. Reserve the recall authorization in eWarranty prior to performing the recall.

Mack Trucks, Inc., recommends a follow-up by telephone or a personal visit, of all owners of vehicles subject to the recall who fail to bring the vehicle(s) in for repair. Your District Service Manager will be contacting you to assure that this recall attains the visibility we feel is necessary to ensure 100% completion. Please be prepared to review your progress and/or any problems associated with the recall.

If you have any questions about this recall, which may not have been covered in this letter or enclosures, please contact the Regulatory Affairs group by email at vtna.regulatoryaffairs@volvo.com

Very truly yours,

MACK TRUCKS, INC.

Enclosures: Customer Notice
Service Bulletin
Notification Cards



SAFETY RECALL

SC335

(Not applicable to Mack Trucks Australia)

Date: 01/11/08 (Supersedes SC335 dated 12/21/07 and cancels SC328 dated 11/16/07)

To: All MACK Dealers

Subject: Internal Check Valve and Supply Port Check Valve Replacement — Bendix SR-7™ Spring Brake Modulating Relay Valve

It has been determined that the internal rubber check valve used with the Bendix SR-7™ spring brake modulating relay valve can become deformed over time, resulting in the check valve not seating properly. With the internal check valve not properly seated, a delay in application of the park brakes could occur, without warning, after the vehicle operator pulls the park brake valve to apply the park brakes, leading to the possibility of an unintended vehicle roll-away.

Additionally, the 90-degree single check valve fitting manufactured by Parker Hannifin which is used in the supply port of the SR-7™ valve has a defect whereby the valve body retainer may become excessively worn and eventually break apart. Pieces of the supply port check valve could become lodged inside the SR-7™ valve, potentially causing air leakage or preventing air from properly exhausting from the valve. This could then cause a delay in the application of the park brakes, the park brakes not fully releasing or a loss of isolation between the primary and secondary air circuits. These conditions can occur without warning, leading to unintended vehicle roll-away, dragging brakes or, in cases of a loss of primary air pressure, the inability to modulate the spring brakes by using the treadle valve.

Approximately 18,786 CXU, CXP, CXN, CHU, CHN, GU, CTP, CT, CV, MRU, and LEU models manufactured between November 4, 2005 and May 1, 2007 are involved in this campaign. A list of affected vehicles has been sent to all applicable dealers.

Procedures:

The internal check valve inside the SR-7™ valve and the supply port check valve must be replaced on all vehicles involved in this campaign. In most cases, the SR-7™ valve is located on the right-hand side of the vehicle, mounted on the crossmember directly in front of the rear drive axle. On certain chassis, however, the SR-7™ valve may be located on the left-hand frame rail.

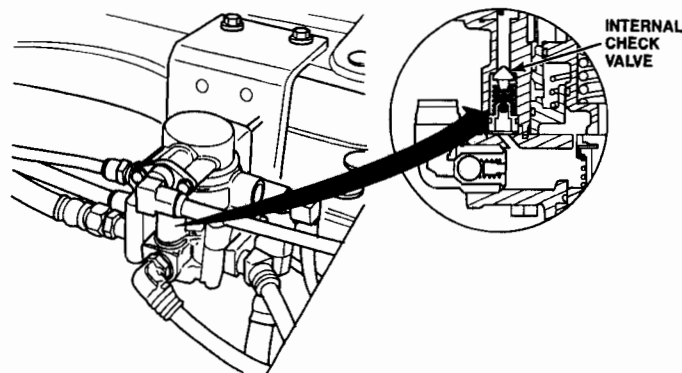

586463a

Figure 1 — Internal Check Valve — Bendix SR-7™ Spring Brake Modulating Relay Valve

SC335 — Page 1 of 5 (with attachment)

For procedures on replacing the internal check valve and the supply port check valve, refer to the two Bendix Installation Instructions, S-1498 and S-1499, attached to this bulletin. These documents are also available online by visiting the Bendix website at www.bendix.com. Be sure to perform the leakage and operational test procedures outlined in the Bendix installation instructions.

The supply port check valve must be removed, inspected and replaced before the internal check valve is replaced. After removal, inspect the supply port check valve to ensure that the internal components of the valve are intact (refer to the following illustration). If the brass retainer is NOT present and intact, or it is broken or damaged, replace the complete SR-7™ valve with valve part No. 745-K022705. If the internal components of the supply port check valve are present and intact, proceed with replacement of the internal check valve and install the replacement supply port check valve.

NOTE

Replace the SR-7™ valve ONLY if the internal components of the supply port check valve are broken, missing or damaged.

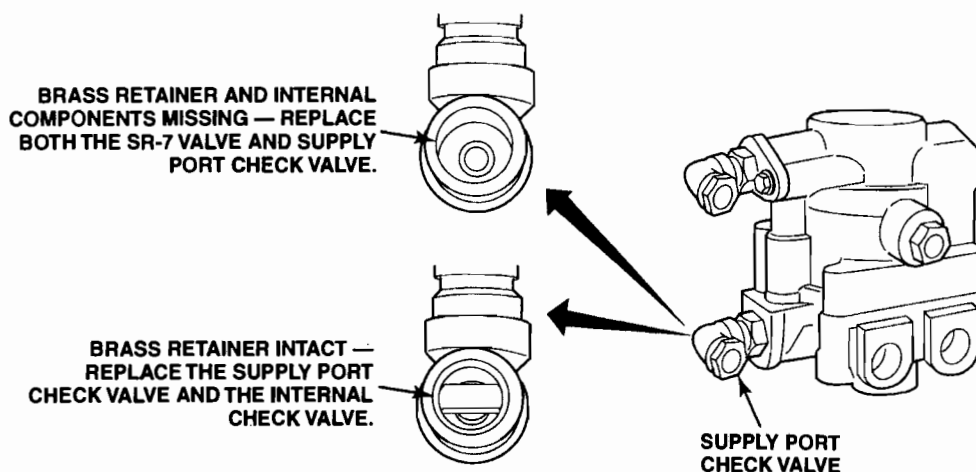

586471a

Figure 2 — Inspect Supply Port Check Valve

NOTE

After the supply port and internal check valves have been replaced, or if the SR-7™ valve was replaced, perform the operation and leakage tests outlined in the attached Bendix bulletin, S-1499, *Installation Instructions, Parker Single Check Valve Replacement Kit*. The tests outlined in these instructions cover both the supply port and internal check valves. The test outlined in the S-1498 bulletin, *Installation Instructions, Internal Check Valve Cartridge Retrofit Kit*, only covers operational and leakage tests for the internal check valve.

Before proceeding, verify Safety Recall campaign eligibility by:

- a. Checking the Safety Recall status in eWarranty.
- b. Checking the campaign completion label located on the passenger-side door, or inside the cab on MRU, and LEU models. If the campaign has been completed, SC335 should be written on the label. Campaign completion can also be verified by checking for the presence of a green tie wrap installed in a conspicuous location on the valve or a fitting.

NOTE

To signify that the campaign has been completed, use a permanent-type marker (such as a Sharpie®) to write the campaign number (SC335) and completion date in the spaces provided on the Campaign Completion label located on the lower edge (below the door latch) of the passenger-side door. If a label is not already affixed to the door, apply a label (part No. TS897) and supply the information as required. Campaign Completion labels are available in packs of 50 and can be ordered by faxing a completed BR313 to Pacesetters Business Services at 610-264-9465.

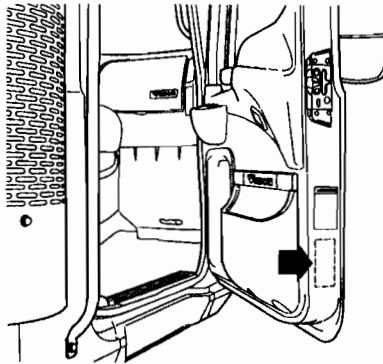

703153a

Figure 3 — Campaign Completion Label Location — Conventional Models

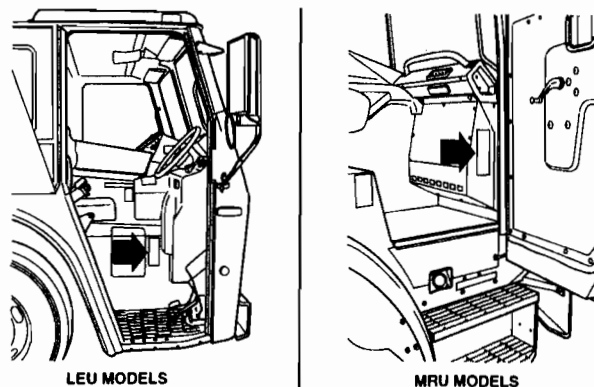

703157b

Figure 4 — Campaign Completion Label Location — MRU and LEU Models

Parts Required:

Order vehicle Safety Recall parts on a separate stock order and process through the parts distribution center normally serving your area. Do not include parts on this requisition that are not required for this safety campaign.

International orders are to be prefixed — V.O.R.

Qty.	Part No.	Description
1	745-K022699	Internal Check Valve Cartridge Retrofit Kit (contains one internal check valve, one extra O-ring, one extra screw and one green tie wrap)
1	745-K022698	External Check Valve Replacement Kit (contains one single check valve fitting and one green tie wrap)
1	745-K022705	SR-7™ valve (if replacement of valve is necessary due to a damaged supply port check valve)

Removed Parts:

The removed internal check valve cartridge and supply port check valve can be scrapped.

If replacement of the SR-7™ valve was necessary because the internal components of the supply port check valve were missing, broken or damaged, both the SR-7™ valve and the supply port check valve **MUST** be returned to Bendix Commercial Vehicle Systems LLC at the address listed below.

SR7 Recall Center
Bendix Commercial Vehicle Systems LLC
901 Cleveland Street
Elyria, Ohio 44035



Return both valves removed from the vehicle along with a copy of the MACK warranty claim form. Use this Bendix-provided UPS® Ground shipping account number (A7T571) for no-cost returns.

NOTE

Return the supply port check valve and the Bendix SR-7™ valve only if the valves were replaced due to a damaged supply port check valve. If the supply port check valve did NOT show signs of damage as indicated on page 2 of this bulletin, it is not necessary to return the components to Bendix. In this case, both valves can be scrapped.

A parts return tag will not be issued by the eWarranty system.

Reimbursement:

Campaign expenses are to be recovered through normal warranty claim procedures. Enter the following information on the warranty claim:

<u>UNDER</u>	<u>ENTER</u>	
Failed Part (Causal Part)	SC0335	
eWarranty Authorization No.....	SC0335	
Labor Code/Allowance	533 2B BC 95 — 0.2 hr.	Time allowed to take charge of vehicle and determine campaign status. NOTE: Only one “take-charge” per vehicle repair visit can be submitted.
	533 2C BC 95 — 0.5 hr.	Time allowed replace the internal check valve and the supply port check valve on vehicles involved in this campaign. Does not include “take-charge” time.
	533 8D BC 95 — 0.7 hr.	Time allowed to remove and replace SR-7™ valve and supply port check valve if the supply port check valve was found to be damaged. Does not include “take-charge” time.

NOTE

As required by Federal Motor Vehicle Safety Standards 49 CFR 573.11, no vehicle subject to an open safety campaign shall be delivered to the customer until such time as the defect or noncompliance is remedied.



Installation Instructions

INTERNAL CHECK VALVE
CARTRIDGE RETROFIT KIT

BENDIX® SR-7™ SPRING BRAKE
MODULATING VALVE

Recall Campaign No.: 07E-037

Vous pouvez vous procurer une copie de ce document en français sur le site www.Bendix.com en cliquant sur le lien "Recall Assistance Center" (Centre d'assistance pour les rappels produits).

Para obtener una copia de este documento en español, usted puede visitarnos al sitio en Internet www.Bendix.com y hacer un clic en el anexo "Recall Assistance Center" (Centro de asistencia para los productos devueltos).

Single Check Valves that might be found in the supply port of the SR-7™ valve

	Parker Single Check Valve Replace under Recall Campaign No. 07E-038
	No replacement necessary

Park control
(From dash valve)

SR-7™ Valves

STOP
If a Parker Single Check Valve (PCV) is present, a second, separate PCV kit will also need to be installed.

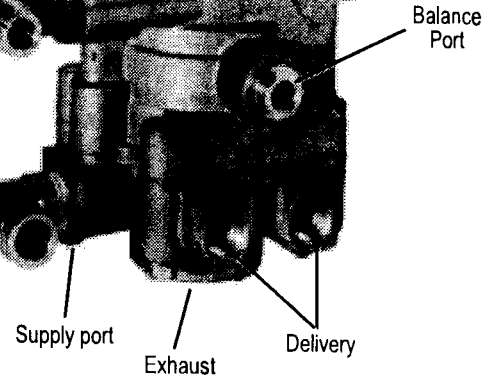

Supply Port with
Pipe Plug
(Installed in Quick Release
Valve Applications)

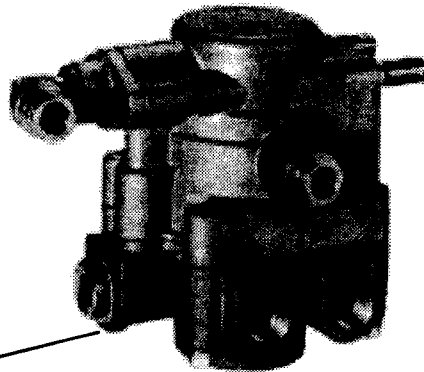

Kit Contents

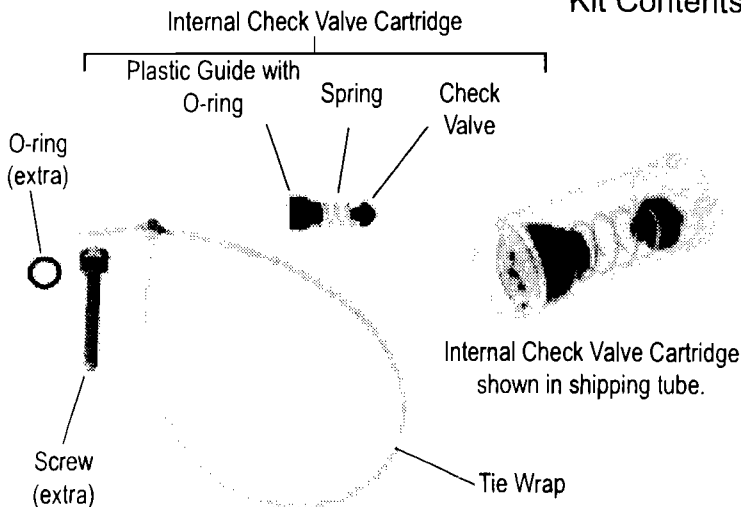

Internal Check Valve Cartridge Retrofit Kit part number **K022699** contains the following components:

Description	Qty.
Internal Check Valve Cartridge	1
Plastic guide with o-ring	
Spring	
Check valve	
O-ring	1 (extra)
Screw	1 (extra)
Green tie wrap	1

Figure 1 - BENDIX® SR-7™ SPRING BRAKE MODULATING VALVE PORT DESIGNATIONS AND KIT CONTENTS

GENERAL

This instruction sheet is intended to provide the necessary information to service the Bendix® SR-7™ spring brake modulating valve with a retrofit internal check valve cartridge. This is in connection with Recall Campaign number 07E-037.

GENERAL SAFETY GUIDELINES

WARNING! PLEASE READ AND FOLLOW THESE INSTRUCTIONS TO AVOID PERSONAL INJURY OR DEATH:

When working on or around a vehicle, the following general precautions should be observed at all times.

1. Park the vehicle on a level surface, apply the parking brakes, and always block the wheels. Always wear safety glasses.
2. Stop the engine and remove ignition key when working under or around the vehicle. When working in the engine compartment, the engine should be shut off and the ignition key should be removed. Where circumstances require that the engine be in operation, EXTREME CAUTION should be used to prevent personal injury resulting from contact with moving, rotating, leaking, heated or electrically charged components.
3. Do not attempt to install, remove, disassemble or assemble a component until you have read and thoroughly understand the recommended procedures. Use only the proper tools and observe all precautions pertaining to use of those tools.
4. If the work is being performed on the vehicle's air brake system, or any auxiliary pressurized air systems, make certain to drain the air pressure from all reservoirs before beginning ANY work on the vehicle. If the vehicle is equipped with an AD-IS® air dryer system or a dryer reservoir module, be sure to drain the purge reservoir.
5. Following the vehicle manufacturer's recommended procedures, deactivate the electrical system in a manner that safely removes all electrical power from the vehicle.
6. Never exceed manufacturer's recommended pressures.
7. Never connect or disconnect a hose or line containing pressure; it may whip. Never remove a component or plug unless you are certain all system pressure has been depleted.
8. Use only genuine Bendix® replacement parts, components and kits. Replacement hardware, tubing, hose, fittings, etc. must be of equivalent size, type and strength as original equipment and be designed specifically for such applications and systems.
9. Components with stripped threads or damaged parts should be replaced rather than repaired. Do not attempt repairs requiring machining or welding unless

specifically stated and approved by the vehicle and component manufacturer.

10. Prior to returning the vehicle to service, make certain all components and systems are restored to their proper operating condition.
11. For vehicles with Antilock Traction Control (ATC), the ATC function must be disabled (ATC indicator lamp should be ON) prior to performing any vehicle maintenance where one or more wheels on a drive axle are lifted off the ground and moving.

SUPPLY LINE REMOVAL

CAUTION: Do not disconnect air lines and fittings unless specified. Installation of this kit does not require that the SR-7™ spring brake modulating valve be removed or that all the air lines be disconnected. **Note:** Instructions for SR-7™ valve removal and installation are included in this document in the event that this kit cannot be installed with the SR-7™ valve mounted on the vehicle.

1. Locate the SR-7™ spring brake modulating valve on the vehicle. Typically it is located near the rear axle mounted on the frame rail or cross member.
2. Identify the supply (SUP 1) port. Note: this port will contain either an external single check valve or a pipe plug. Refer to Figure 1.
3. If an external single check valve is present, disconnect the air line to the check valve. Refer to Figures 2 and 3.

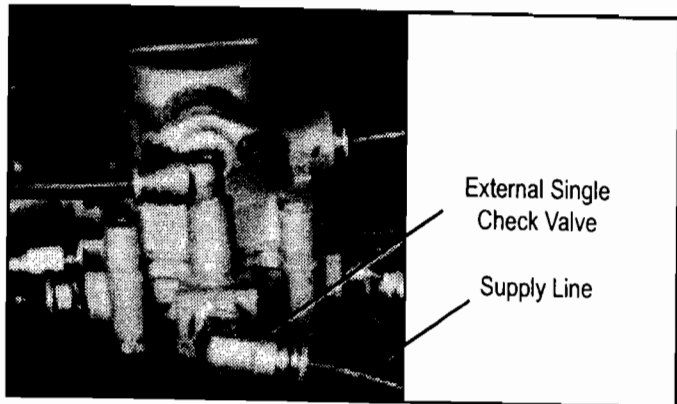

Figure 2 - SR-7™ VALVE AND EXTERNAL SINGLE CHECK VALVE

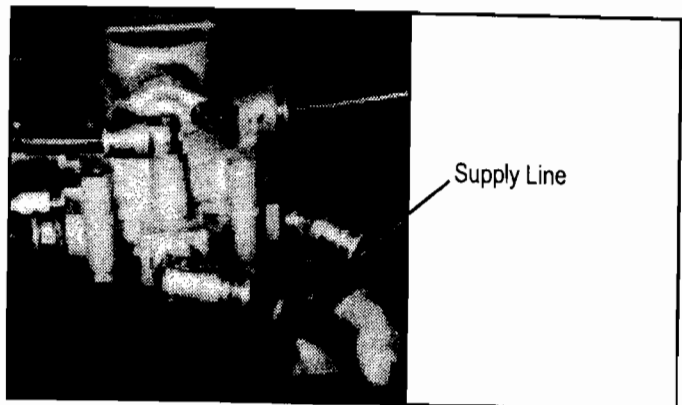

Figure 3 - DISCONNECTING THE SUPPLY LINE

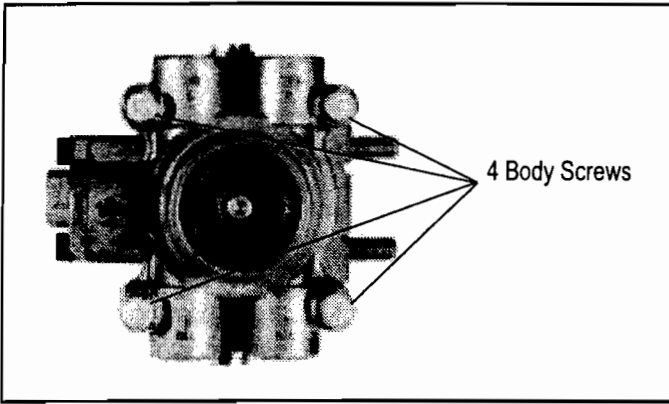

Figure 4 - BOTTOM VIEW OF SR-7™ VALVE

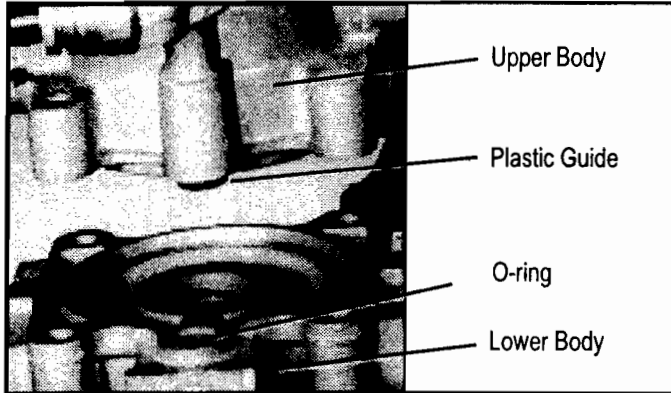

Figure 5 - PLASTIC GUIDE AND O-RING SEAL

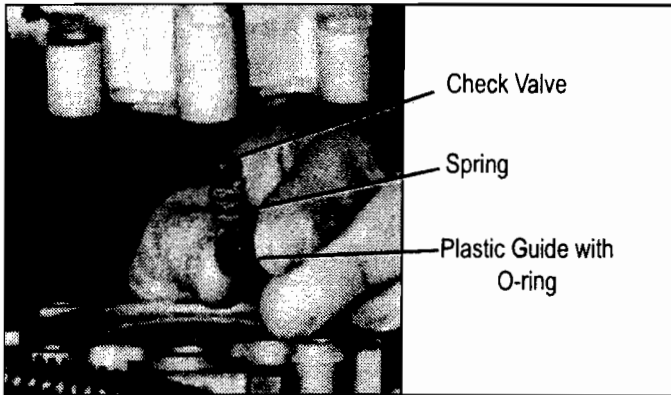

Figure 6 - INTERNAL CHECK VALVE

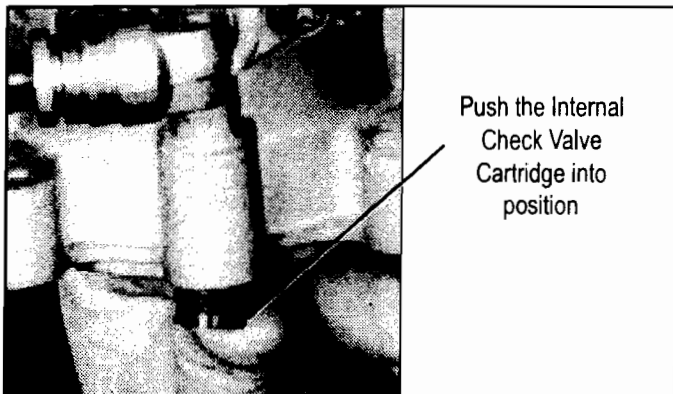

Figure 7 - CARTRIDGE INSTALLATION

INTERNAL CHECK VALVE REMOVAL

4. Using a 7/16" wrench remove the four screws that secure the upper and lower bodies of the SR-7™ valve. Refer to Figure 4. Do not disconnect additional hoses or fittings. The separation between the upper and lower body should be approximately three inches to allow adequate room to install this kit.
5. Locate the plastic guide in the upper body of the SR-7™ valve directly above the supply port. The o-ring seal from the lower body may stick to the plastic guide when the bodies are separated. If so, remove it from the guide and place it back into the lower body. An extra o-ring has been included in this kit in the event that the o-ring is lost or damaged during servicing. Refer to Figure 5.
6. Remove the plastic guide, spring and check valve from the valve bore and discard. Note: The check valve may stick to its seat in the upper body. Be sure that all of the components are removed before going to the next step. Refer to Figure 6.

CARTRIDGE INSTALLATION

1. Insert the replacement cartridge in the bore where the check valve, spring and plastic guide were removed. Note: Be sure to remove the replacement cartridge from its shipping tube prior to installation. Push the cartridge into position until it stops as shown in Figure 7. A portion of the plastic guide in the cartridge will stick out as shown in Figure 8. **DO NOT FORCE THE CARTRIDGE FURTHER INTO THE BORE.**

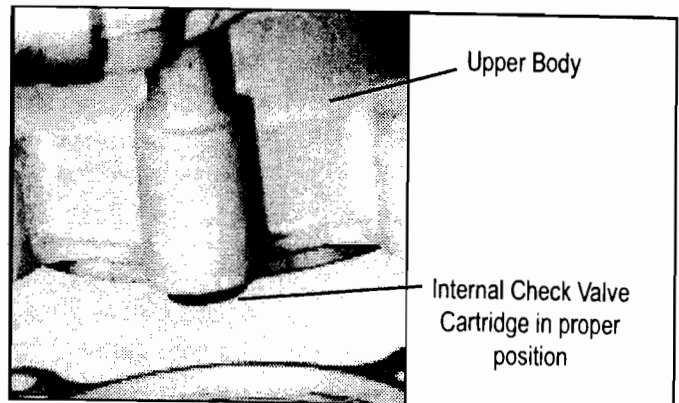

Figure 8 - PROPER CARTRIDGE INSTALLATION

2. As shown in Figures 9 and 10, align the valve lower body with the upper body. Push the body halves together. Insert two of the four screws (finger tight) into the lower body mounting holes closest to the supply port first. This will help with alignment. One extra screw is included in this kit in the event one is lost during installation.
3. Insert the remaining two screws and tighten finger tight. Tighten all four screws to 80-100 in. lbs.
4. Reconnect any air lines that were disconnected.
5. Secure the enclosed tie wrap on the valve or fitting in a conspicuous location to identify the field repair has been performed.
6. Proceed to "Testing the SR-7™ Spring Brake Modulating Valve."

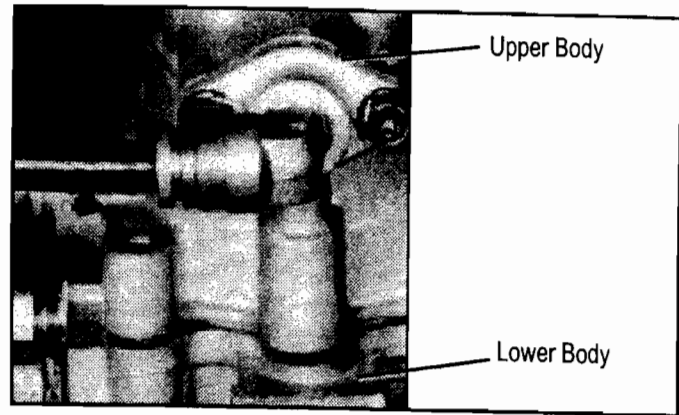

Figure 9 - POSITIONING THE UPPER & LOWER BODY

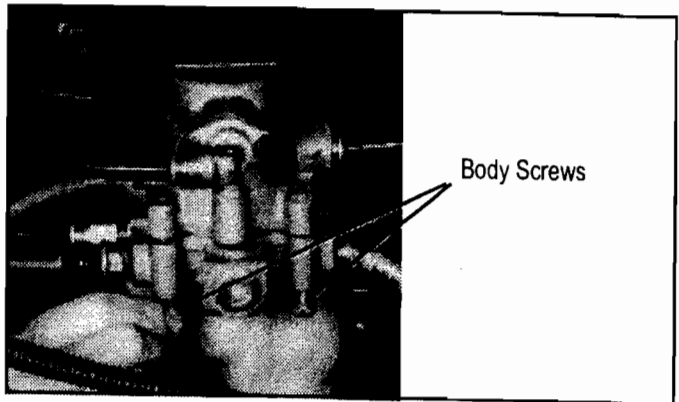

Figure 10 - SECURING THE UPPER & LOWER BODY
(QUICK RELEASE VERSION SHOWN)

VALVE REMOVAL (IF REQUIRED)

In case installation of the internal check valve cartridge is not feasible or the entire SR-7™ valve is required to be replaced due to damaged or missing components in the Parker single check valve, follow these steps for removal.

1. Prior to removing the SR-7™ valve, review the general safety guidelines of this document.
2. Identify and mark all air lines before disconnecting.
3. Remove the two mounting nuts that secure the valve to the frame rail and remove the valve.
4. Compare the valve that was removed to the replacement valve. If the valve that was removed contains fittings or pipe plugs that the new valve does not, note their orientation and remove the fittings.
5. If the removed SR-7™ valve contains an external single check valve in the supply port, identify the type of single check valve. **If the SR-7™ valve contains a Parker single check valve, do not reuse it in the replacement valve. Refer to Figure 1 for single check valve identification. The Parker single check valve is covered by Recall Campaign No. 07E-038. Contact the Bendix Recall Center for a replacement.**
6. If the external check valve located in the supply port is not a Parker check valve, it must be removed and installed on the replacement SR-7™ valve. A standard fitting is **not** an acceptable substitute.
7. Using pipe sealant, install the fittings that were removed into the replacement SR-7™ valve. Be sure that orientation of the fittings is the same. Teflon tape is not an acceptable substitute for pipe sealant. Install fittings finger tight, then tighten 1.5 - 2 turns. For shaped fittings, such as tees and elbows, tighten no more than one additional turn to the final position.

VALVE INSTALLATION (IF REQUIRED)

1. Align the valve mounting studs with the mounting holes on the vehicle frame rail. Tighten the mounting nuts to 180-220 in. lbs.
2. Install the valve onto the vehicle ensuring all air lines are connected as marked during disassembly.

TESTING THE SR-7™ SPRING BRAKE MODULATING VALVE

Perform operating and leakage tests as outlined below.

OPERATING TEST

Block vehicle and hold by means other than vehicle brakes. Charge air brake system to governor cut-out pressure.

Place parking control valve in "release" position. Observe that spring brake actuators release fully.

Place parking control valve in "park" position. Observe that spring brake actuators apply promptly, within 3 seconds.

LEAKAGE TEST

Place the park control valve in the "release" position; using a soap solution, coat all ports including the exhaust port and external check valve, if applicable. A 1" bubble in 3 seconds is permitted (175 SCCM).

If the SR-7™ valve does not function as described, or if leakage is excessive, it is recommended that it be replaced with a new unit available from a Bendix parts outlet.

INSTALLATION IDENTIFICATION

If the tie wrap has not already been secured to the valve, secure it to the valve or fitting in a conspicuous location to identify that the field repair has been performed.

**Recall Assistance Center
1-877-461-2732**

www.Bendix.com

sr7campaign@bendix.com





Installation Instructions

PARKER SINGLE CHECK VALVE REPLACEMENT KIT

BENDIX® SR-7™ SPRING BRAKE MODULATING VALVE

Recall Campaign No.: 07E-038

Vous pouvez vous procurer une copie de ce document en français sur le site www.Bendix.com en cliquant sur le lien "Recall Assistance Center" (Centre d'assistance pour les rappels produits).

Para obtener una copia de este documento en español, usted puede visitarnos al sitio en Internet www.Bendix.com y hacer un clic en el anexo "Recall Assistance Center" (Centro de asistencia para los productos devueltos).

Single Check Valves that might be found in the supply port of the SR-7™ valve

SR-7™ Valve port designations

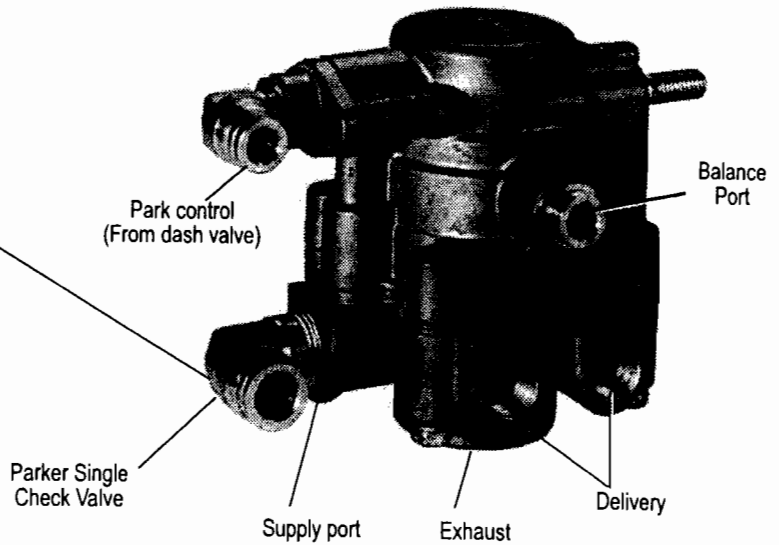
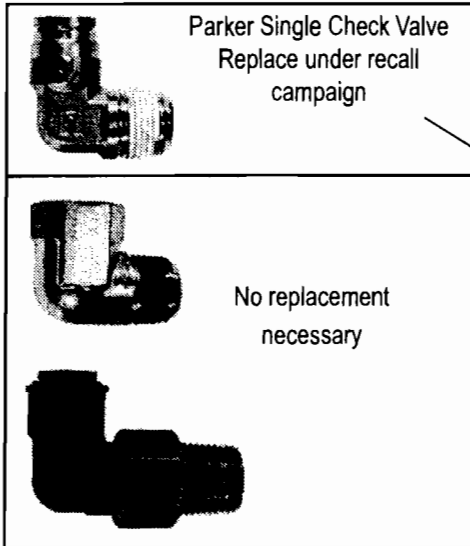

Kit Contents

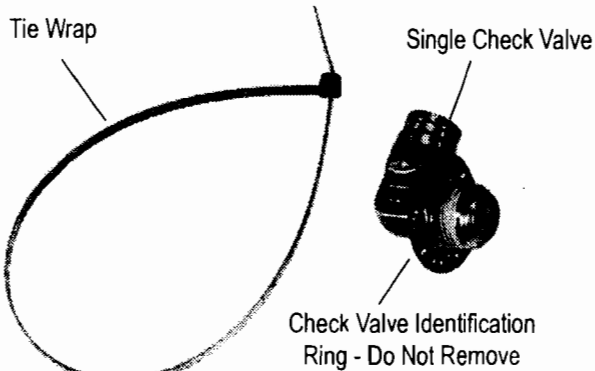

External single check valve replacement kit part number **K022698** contains the following components:

Description	Qty.
Single Check Valve	1
Green Tie Wrap	1

Figure 1 - BENDIX® SR-7™ SPRING BRAKE MODULATING VALVE PORT DESIGNATIONS AND KIT CONTENTS

GENERAL

This instruction sheet is intended to provide the necessary information to replace the Parker external single check valve attached to the supply port of an SR-7™ spring brake modulating valve in connection with Recall Campaign number 07E-038.

GENERAL SAFETY GUIDELINES

WARNING! PLEASE READ AND FOLLOW THESE INSTRUCTIONS TO AVOID PERSONAL INJURY OR DEATH:

When working on or around a vehicle, the following general precautions should be observed at all times.

1. Park the vehicle on a level surface, apply the parking brakes, and always block the wheels. Always wear safety glasses.

2. Stop the engine and remove ignition key when working under or around the vehicle. When working in the engine compartment, the engine should be shut off and the ignition key should be removed. Where circumstances require that the engine be in operation, **EXTREME CAUTION** should be used to prevent personal injury resulting from contact with moving, rotating, leaking, heated or electrically charged components.
3. Do not attempt to install, remove, disassemble or assemble a component until you have read and thoroughly understand the recommended procedures. Use only the proper tools and observe all precautions pertaining to use of those tools.
4. If the work is being performed on the vehicle's air brake system, or any auxiliary pressurized air systems, make certain to drain the air pressure from all reservoirs before beginning ANY work on the vehicle. If the vehicle is equipped with an AD-IS® air dryer system or a dryer reservoir module, be sure to drain the purge reservoir.
5. Following the vehicle manufacturer's recommended procedures, deactivate the electrical system in a manner that safely removes all electrical power from the vehicle.
6. Never exceed manufacturer's recommended pressures.
7. Never connect or disconnect a hose or line containing pressure; it may whip. Never remove a component or plug unless you are certain all system pressure has been depleted.
8. Use only genuine Bendix® replacement parts, components and kits. Replacement hardware, tubing, hose, fittings, etc. must be of equivalent size, type and strength as original equipment and be designed specifically for such applications and systems.
9. Components with stripped threads or damaged parts should be replaced rather than repaired. Do not attempt repairs requiring machining or welding unless specifically stated and approved by the vehicle and component manufacturer.
10. Prior to returning the vehicle to service, make certain all components and systems are restored to their proper operating condition.
11. For vehicles with Antilock Traction Control (ATC), the ATC function must be disabled (ATC indicator lamp should be ON) prior to performing any vehicle maintenance where one or more wheels on a drive axle are lifted off the ground and moving.

PARKER SINGLE CHECK VALVE REPLACEMENT

CAUTION: Do not disconnect air lines and fittings unless specified. Installation of this kit does not require that the SR-7™ spring brake modulating valve be removed or that all the air lines be disconnected.

1. Locate the SR-7™ valve on the vehicle. Typically, it is located near the rear axle mounted on the frame rail or cross member.

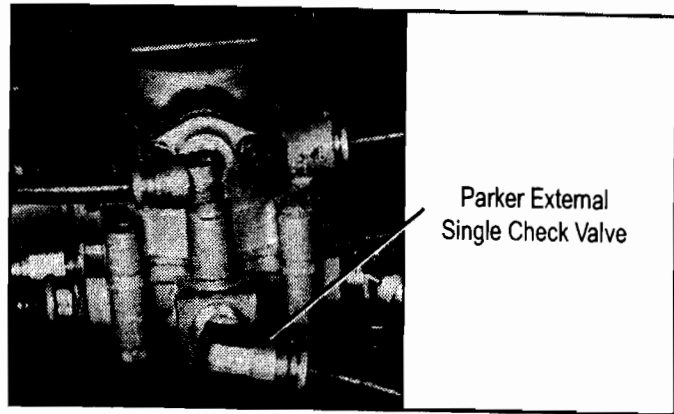

Figure 2 - SR-7™ VALVE & PARKER SINGLE CHECK VALVE

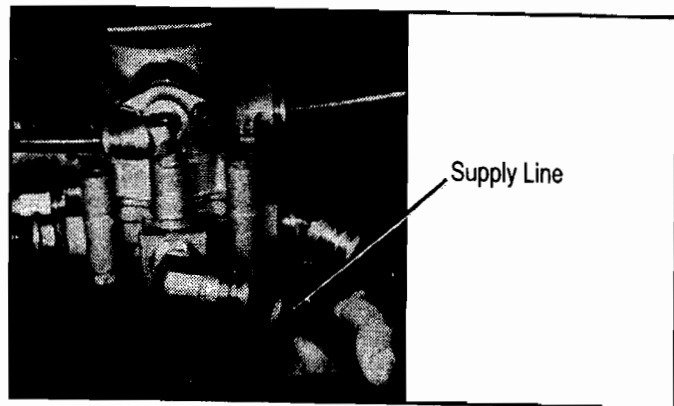

Figure 3 - DISCONNECTING THE SUPPLY LINE

2. Locate the external single check valve installed in the supply port of the SR-7™ valve as shown in Figure 1.
3. **Note: Verify the external check valve is a Parker single check valve. Refer to Figure 1. If the check valve is not a Parker single check valve, replacement of the check valve is not necessary and is not covered by this campaign.**
4. Remove the 1/2" OD supply line from the Parker single check valve supply port. See Figures 2 and 3. **Note:** Some SR-7™ valves may have a fitting between the single check valve and the SR-7™ valve.
5. Note the orientation of and remove the external check valve. Refer to Figures 4 and 5. **IMPORTANT: Inspect the outlet (threaded side) of the Parker single check valve to ensure the presence of check valve components. Verify that the brass retainer is present and intact. Refer to Figure 6.**
6. **NOTE: If the brass retainer is NOT present and intact, both the Parker external single check valve AND the entire SR-7™ valve must be replaced. Do not proceed with this kit.** The SR-7™ valve replacement kit part must be obtained and installed.

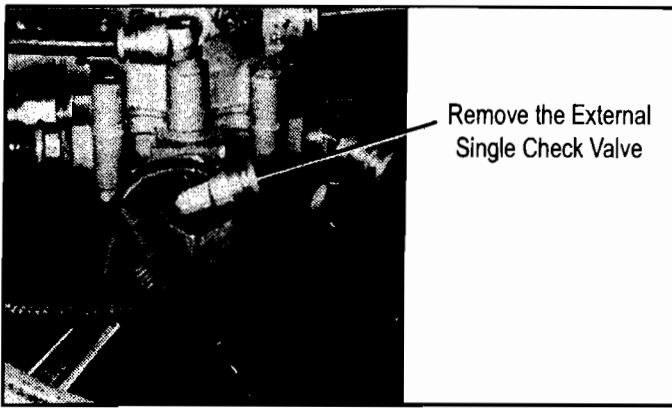

Figure 4- REMOVING THE EXTERNAL SINGLE CHECK VALVE

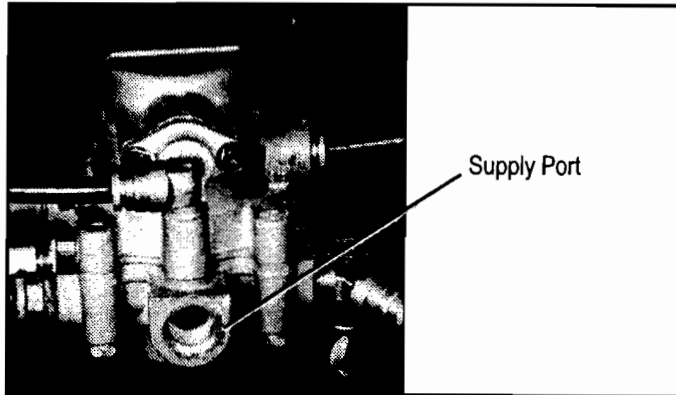

Figure 5- EXTERNAL SINGLE CHECK VALVE REMOVED

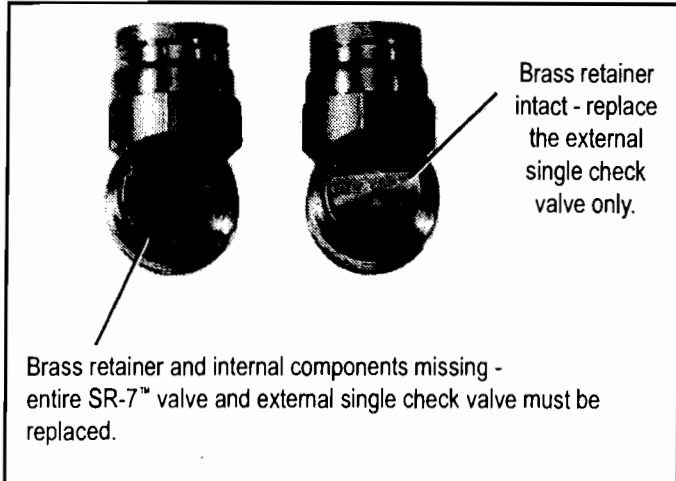

Figure 6 - PARKER SINGLE CHECK VALVE

TESTING THE SR-7™ SPRING BRAKE MODULATING VALVE

Perform operating and leakage tests as outlined below.

OPERATING TEST

Block vehicle and hold by means other than vehicle brakes. Charge air brake system to governor cut-out pressure.

Place parking control valve in "release" position. Observe that spring brake actuators release fully.

Place parking control valve in "park" position. Observe that spring brake actuators apply promptly, within 3 seconds.

LEAKAGE TEST

Place the park control valve in the "release" position; using a soap solution, coat all ports including the exhaust port and external check valve, if applicable. A 1" bubble in 3 seconds is permitted (175 SCCM).

With both service reservoirs at 120 PSI, decrease the pressure at the secondary reservoir to 0 PSI. The primary reservoir should not drop below 100 PSI.

If the Parker external check valve or SR-7™ valve do not function as described, or if leakage is excessive, it is recommended that it be replaced with a new unit available from a Bendix parts outlet.

INSTALLATION IDENTIFICATION

If the tie wrap has not already been secured to the valve, secure it to the valve or fitting in a conspicuous location to identify that the field repair has been performed.

Recall Assistance Center
1-877-461-2732

www.Bendix.com

sr7campaign@bendix.com

7. Using pipe sealant install the new external single check valve and any fittings that were removed. **Note:** Do not remove the check valve identification ring from the replacement single check valve. Be sure that orientation of the fittings is the same. Teflon tape is not an acceptable substitute for pipe sealant. Install fittings finger tight, then tighten 1.5 - 2 turns. For shaped fittings, such as tees and elbows, tighten no more than one additional turn to the final position.
8. Reconnect any air lines that were disconnected.





MACK TRUCKS, INC.
2100 MACK BOULEVARD
P.O. BOX M
ALLENTOWN, PA 18105-5000

**SAFETY RECALL SC0335
MAY 2008**

DEAR MACK TRUCK OWNER:

This notice is sent to you in accordance with the requirements of the National Traffic and Motor Vehicle Safety Act.

Mack Trucks, Inc. has decided that a defect, which relates to motor vehicle safety, exists in certain Mack vehicles manufactured from November 4, 2005 through May 1, 2007.

SAFETY DEFECT: The internal rubber check valve inside the spring brake modulating valve can become deformed over time, which could potentially result in a delay, or failure to apply the park brakes when pulling the yellow park brake control knob on the dash.

Also, the valve body retainer of the single check valve that connects to the spring brake modulating valve may become excessively worn over time, which could potentially result in a delay, or failure to apply the park brakes when pulling the yellow park brake control knob on the dash; and, the park brakes may not fully release when pushing the yellow park brake control knob on the dash, causing the brakes to drag on the vehicle.

SAFETY RISK: The delay or failure of the parking brake application can occur without warning and possibly lead to unintended vehicle rollaway, which could result in a vehicle crash.

Dragging brakes can result in overheating of the rear drums, which may result in a rear tire fire and subsequent rear tire failure.

PRECAUTIONS YOU CAN TAKE: There are no precautions you can take other than having your vehicle repaired by a Mack Parts and Service Center.

TIME REQUIRED FOR THE REPAIR: The time required to repair your vehicle is approximately one hour.

WHAT YOU SHOULD DO: You should contact the nearest Mack Parts and Service Center and make an appointment. The spring brake modulating valve will be repaired and the single check valve will be replaced at **no charge** to you. All Mack Parts and Service Centers have been sent a bulletin covering all the details required to perform the safety recall.

You can locate the closest Mack Parts and Service Center by going on line to <http://www.macktrucks.com/> and selecting "Dealer & Service Locations" or by calling our toll-free number: (800) 866-1177.

**NOTICE REGARDING
LEASED VEHICLES:**

If you are a Lessor of vehicles subject to this Notice, you have an obligation under Federal Law to provide a copy of this Notice to all Lessees within 10 days of your receipt of this Notice. Further, you must maintain a record, which identifies the Lessee(s) to whom you send a copy of this letter, the date you send this letter, and the Vehicle Identification Number(s) of the vehicle(s) that you have leased to that lessee. For purposes of this Notice, the term Lessor means: a person or entity that is the owner, as reflected on the vehicle's title, of any five or more leased vehicles (as defined in CFR Section 577.4), as of the date of notification by the manufacturer of the existence of a safety-related defect or non-compliance with a Federal Motor Vehicle Safety Standard in one or more of the leased motor vehicles.

**OWNER RECALL
RESPONSE CARD:**

The enclosed "Notice of Vehicle Recall" identifies your vehicle. If you no longer own the vehicle, please help us update our records by completing the "Vehicle Disposition Record" portion of the enclosed postage-free Notice of Mandatory Safety Campaign card and mailing it back to us.

**ASSISTANCE/
COMPLAINTS:**

If your vehicle has not been repaired within a reasonable time after delivering it to a Mack Parts and Service Center, please contact:

Mack Trucks Inc.
Regulatory Affairs Department,
P.O. Box 26115
Greensboro, NC 27402-6115
vtna.regulatoryaffairs@volvo.com

You may also submit complaints to the Administrator of the National Highway Safety Administration (1200 New Jersey Avenue, S.E., Washington DC 20590 or call the toll-free Auto Safety Hot Line at 1-888-327-4236 (TTY: 1-800-424-9153), or go to <http://www.safercar.gov> if you believe that Mack Trucks Inc. has failed to remedy the defect without charge, or has failed to remedy the vehicle within 60 days of the owners first tender to obtain repair following the earliest time that parts are available.

**PRE NOTIFICATION
REMEDIES:**

If you have previously paid for repairs as a result of this issue, you may be entitled to recovery of those expenses.

Submit copies of all documentation supporting your claim according to the rules specified in the "General Plan for Reimbursement of Pre-notification Remedies" provided in this mailing.

We regret any inconvenience this may cause to your operation, but hope you will appreciate our sincere efforts to demonstrate Mack's commitment to provide our customers with the best possible product.

MACK TRUCKS, INC.

General Plan for Reimbursement of Pre-Notification Remedies

Mack Trucks Inc. will administer this plan through its Corporate Regulatory Compliance Department.

The provisions of this plan set forth the procedures to be followed for reimbursing owners (claimants) for the costs associated with repairs performed prior to notification of a recall, to remedy safety defects and non-compliances.

Required Information:

If the claimant's Mack vehicle is affected by a recall campaign and the claimant had the problem corrected at their own expense prior to receiving notification of the recall, Mack Trucks will reimburse the claimant by check for the reasonable amount paid for the appropriate pre-remedy repairs (i.e. the cost of parts, labor, taxes and disposal fees) in accordance with the provisions set forth in this document. In order to process each claim, the claimant **MUST** submit the following documentation to support the request to the Regulatory Compliance Department as specified in the section titled "*Contact Information*":

- Claimant's name, mailing address, and telephone number; and,
- The recall number, title, and description; and,
- The complete 17 digit Vehicle Identification Number (V.I.N.); and,
- A notarized statement by the claimant that the pre-notification repair addressed the defect specified in the owner notification letter; and,
- A copy of the repair invoice or receipt for the repairs.
 - The invoice / receipt must provide the VIN, total amount paid (i.e. total amount of reimbursement requested by the claimant), and include a breakdown of the parts, labor, and other costs.

Limitation of Claims

Mack Trucks will consider all claims, but may deny all or part of the claim for any of the following reasons:

- The vehicle was not part of the recall;
- The repairs were performed more than one (1) year prior to the date, that Mack Trucks notified the National Highway Traffic Safety Administration or Transport Canada, that a safety related defect or non-compliance exists;
- The repairs were performed more than 10 calendar days after the last mailing of the initial customer notification letter, pertaining to the recall;
- The vehicle was still covered by warranty or extended warranty on the date of repair which would have provided a free repair;
- If the receipt / invoice is not itemized by parts & labor;
- If the repair did not address the safety defect or non-compliance that led to the recall;
- If the repair was not reasonably necessary to correct the safety defect or non-compliance that led to the recall;
- If the claim is fraudulent;
- If the repair was not of the same type (repair, replacement, and refund) as the recall remedy;
- If adequate documentation as described above is not submitted to the appropriate address specified in this plan in the section titled "*Contact Information*".

Contact Information

Submit copies of all documentation supporting your claim to:

Mack Trucks Inc.
Regulatory Compliance Department
Attn: Regulatory Compliance Administrator
P.O. Box 26115
Greensboro, NC 27402-6115

Claims will be processed within 60 days of receipt