



Nasser Zamani
Manager
Compliance and Regulatory Affairs

Freightliner LLC
4747 N. Channel Ave
Portland, OR 97217-7699
503-745-6910 Phone
503-745-5544 Fax
NasserZamani@Freightliner.com

September 4, 2007

Dan Smith
Associate Administrator for Vehicle Safety
National Highway Traffic Safety Administration
1200 New Jersey Avenue S.E.
Washington, D.C. 20590

**Re: Defect Information Report (FL-500), NHTSA 07V-266,
Supplemental Report No.: 1, York Grease Filled Hubs**

Mr. Smith:

In accordance with Part 573 of Title 49 of the Code of Federal Regulations, Freightliner LLC herewith submits supplemental defect information.

(c) (1) Manufacturer: FREIGHTLINER LLC
P.O. BOX 3849
Portland, Oregon 97208
(503) 745-5219

(c)(3) Total number of vehicles potentially affected: 54

(c) (10) Communications sent to dealers (attached): posted July 31, 2007
Communications sent to owners (attached): mailed August 3, 2007

Please contact me if you have any questions.

Sincerely yours,

Nasser Zamani

Cc: Michael Mason, CAL-OSHA
Certified Mail# 700428900004/12021031

Subject: Front Wheel Bearing and Hub Lubrication

Models Affected: Specific Freightliner Business Class M2 vehicles manufactured between October 4, 2006, and October 10, 2006.

General Information

Freightliner LLC, on behalf of its Freightliner Trucks Division, has decided that a defect which relates to motor vehicle safety exists on the vehicles mentioned above.

There are approximately 50 vehicles involved in this campaign.

Certain vehicles may have been manufactured with inadequate amounts of grease in the hubs or hub cavities. Inadequate lubrication of the front wheel bearings can lead to a bearing failure and a possible vehicle crash without prior warning.

The front wheel bearings will be inspected and replaced if necessary.

Additional Repairs

Dealers must complete all outstanding recall and field service campaigns prior to the sale or delivery of a vehicle. A Dealer will be liable for any progressive damage that results from its failure to complete campaigns before sale or delivery of a vehicle.

Owners may be liable for any progressive damage that results from its failure to complete campaigns within a reasonable time after receiving notification.

Work Instructions

Please refer to the attached work instructions. Prior to performing the campaign, check the vehicle for a completion sticker (Form WAR260).

Replacement Parts

Replacement kits will not be used for this campaign. When needed, please use the parts listed in **Table 1** below.

If our records show your dealership has ordered any vehicles involved in campaign number FL500A, a list of the customers and vehicle identification numbers will be available on AccessFreightliner.com. Please refer to this list when ordering parts for this recall.

Table 1 - Replacement Parts for FL500

Campaign Number	Part Description	Part Number	Qty. per Kit	Suggested Wholesale*
FL500A	Outer Bearing	SBN 3782TRB	2 ea	\$10.98 U.S. \$13.24 CAN
	Inner Bearing	SBN HM212049TRB	2 ea	\$15.38 U.S. \$18.55 CAN
	Outer Bearing Cup	CM 100209	2 ea	\$8.65 U.S. \$9.51 CAN
	Inner Bearing Cup	CM 100015	2 ea	\$12.53 U.S. \$13.79 CAN
	Hub Cap Gaskets	STM 330 3024	2 ea	\$1.25 U.S. \$1.43 CAN
	Wheel Seal	CHR 35066	2 ea	\$21.36 U.S. \$27.78 CAN
	Grease	MBL SHC007	1 qt	N/A

* Please charge all Direct Warranty Customers the above-listed price for the kit, as they are authorized to perform their own Recalls.

Recall Campaign

July 2007
 FL500A
 NHTSA #07V-266

Removed Parts

Please follow Warranty Failed Parts Tracking shipping instructions for the disposition of all removed parts.

Labor Allowance

Table 2 - Labor Allowance

Campaign Number	Procedure	Time Allowed (hours)	SRT Code	Damage Code
FL500A	Inspect front wheel bearings	0.4	996-0718B	000-Inspected
	Inspect and remove and replace front wheel bearings	1.8	996-0718A	000-Modifiedx

Table 2

IMPORTANT: When the recall has been completed, locate the base completion label in the appropriate location on the vehicle, and attach the red completion sticker provided in the recall kit (Form WAR260). If the vehicle does not have a base completion label, clean a spot on the appropriate location of the vehicle and first attach the base completion label (Form WAR259). If a recall kit is not required or there is no completion sticker in the kit, write the recall number on a blank sticker and attach it to the base completion label.

Claims for Credit

You will be reimbursed for your parts, labor, and handling by submitting your claim through the Warranty system within 30 days of completing this campaign. Please reference the following information in QuickClaim®:

- Claim type is **Recall**.
- In the FTL Authorization field, enter the campaign number and appropriate condition code (**FL500A**).
- In the Primary Failed Part Number field, enter **25-FL500-000**.
- In the Parts field, enter the appropriate part number(s) as shown in the Replacement Parts Table.
- In the Labor field, first enter the appropriate SRT from the Labor Allowance Table. For administrative time, enter SRT 939-0010A for 0.3 hours.

IMPORTANT: ServicePro® must be viewed prior to performing the recall to ensure the vehicle is involved and the campaign has not been previously completed. Also, check for a completion sticker prior to beginning work.

Contact the Warranty Campaigns Department at (800) 547-0712, from 7:00 a.m. to 4:00 p.m. Pacific Time, Monday through Friday, Web inquiry at [AccessFreightliner.com / Support / Submit an Inquiry](http://AccessFreightliner.com/Support/SubmitanInquiry), or the Customer Assistance Center at (800) 385-4357, after normal business hours, if you have any questions or need additional information.

To return excess kit inventory related to this campaign, U.S. dealers must submit a Parts Authorization Return (PAR) to the Memphis PDC. Canadian dealers must submit a PAR to their facing PDC. All kits must be in resalable condition. PAR requests must include the original purchase invoice number.

The letter notifying vehicle owners is included for your reference.

Please note that the National Traffic and Motor Vehicle Safety Act, as amended (Title 49, United States Code, Chapter 301), requires the owner's vehicle(s) be corrected within a reasonable time after parts are available to you. The Act states that failure to repair a vehicle within 60 days after tender for repair shall be prima facie evidence of an unreasonable time. However, circumstances of a particular situation may reduce the 60 day period. Failure to repair a vehicle within a reasonable time can result in either the obligation to (a) replace the vehicle with an identical or reasonably equivalent vehicle, without charge, or (b) refund the purchase price in full, less a reasonable allowance for depreciation. The Act further prohibits dealers from selling a vehicle unless all outstanding recalls are performed. Also, any lessor is required to send a copy of the recall notification to the lessee.

Copy of Letter to Owner

Subject: Front Wheel Bearings and Hub Lubrication

This notice is sent to you in accordance with the requirements of the National Traffic and Motor Vehicle Safety Act. This notice is also sent in accordance with the Canadian Motor Vehicles Safety Act.

Freightliner LLC, on behalf of Freightliner Trucks Division has decided that a defect which relates to motor vehicle safety exists on specific Freightliner Business Class M2 vehicles manufactured between October 4, 2006, and October 10, 2006.

Certain vehicles may have been manufactured with inadequate amounts of grease in the hubs or hub cavities. Inadequate lubrication of the front wheel bearings can lead to a bearing failure and a possible vehicle crash without prior warning.

The front wheel bearings will be inspected and replaced if necessary.

Contact your authorized dealer to arrange to have your vehicle(s) inspected and to assure that parts are available at the dealer if needed. To locate a dealer, search online at www.FreightlinerTrucks.com or contact the Warranty Campaigns Department for assistance.

When you contact your dealer, refer to campaign number **FL500A**. The recall may take up to two hours and will be performed at no charge to you.

IMPORTANT: When the Recall has been completed, please ensure that a label has been affixed to your vehicle referencing **FL500A**.

If you do not own the vehicle that corresponds to the identification number(s) which appears on the Recall Notification, please return the notification to the Warranty Campaigns Department with any information you can furnish that will assist us in locating the present owner. If you have leased this vehicle, Federal law requires that you forward this notice to the lessee within 10 days.

If you are not able to have the defect remedied without charge and within a reasonable time, which is not longer than 60 days after you tender the vehicle for repair, please contact the Warranty Campaigns Department at (800) 547-0712, 7:00 a.m. to 4:00 p.m. Pacific Time, Monday through Friday, e-mail address WarrantyCampaigns@freightliner.com, or the Customer Assistance Center at (800) FTL-HELP or (800) STL-HELP, after normal business hours. You may also wish to submit a complaint to the Administrator, National Highway Traffic Safety Administration, 1200 New Jersey Avenue, SE., Washington, DC 20590; or call the Vehicle Safety Hotline at (888) 327-4236 (TTY: 800-424-9153); or to <http://www.safercar.gov>. If your vehicle is involved in the Canadian portion, you may wish to notify Transport Canada, ASFAD, Place de Ville Tower C, 330 Sparks Street, Ottawa, ON K1A 0N5, or phone (800) 333-0510.

We regret any inconvenience this action may cause but feel certain you understand our interest in motor vehicle safety.

WARRANTY CAMPAIGNS DEPARTMENT

Enclosure

Recall Campaign

July 2007
FL500A
NHTSA #07V-266

Work Instructions

Subject: Front Wheel Bearings and Hub Lubrication

Models Affected: Specific Freightliner Business Class M2 vehicles manufactured between October 4, 2006, and October 6, 2006.

Front Wheel Bearing Inspection Procedure

1. Check the base label (Form WAR259) for a completion sticker for FL500 (Form WAR260) indicating this work has been done. The base label is usually located on the passenger-side door about 12 inches (30 cm) below the door latch. If a sticker for FL500 is present, nothing further needs to be done. If no sticker is present, go to the next step.
2. Shut down the engine, set the parking brake, and chock the tires.
3. Remove the hub cap.
4. Check that the hub cap is half full of grease.

If the hub cap is half full of grease, the hubs were properly greased and no further work is necessary. Place the hub cap and a new gasket in position and install the washers and cap screws. Tighten the cap screws 20 to 30 lbf-ft (27 to 41 N-M). Then proceed to step 31.

If the hub cap is not half full of grease, the hubs were not properly greased and the bearings need to be replaced. Proceed to step 5.

5. Raise the front of the vehicle just enough to take the weight from the wheels, but with the tires still touching the ground.
6. Loosen the wheel nuts.

WARNING

Use safety stands to support the vehicle. Never work under a vehicle that is supported only by jacks. Jacks can slip, causing the vehicle to fall, which could result in serious injury or death.

7. Raise the vehicle until the tires clear the ground and support it with safety stands.
8. Remove the tire-and-wheel assemblies from the vehicle.

WARNING

Wear a respirator at all times when working around the brakes. Breathing brake lining dust (asbestos or non-asbestos) could cause lung cancer or lung disease. OSHA has set maximum levels of exposure and requires workers to wear an air purifying respirator approved by MSHA or NIOSH.

9. On one side of the vehicle, remove the brake drum. For instructions, see **Group 42** of the applicable vehicle workshop manual.

To minimize the possibility of creating airborne brake lining dust, clean the dust from the brake drum, brake backing plate, and brake assembly using an industrial-type vacuum cleaner equipped with a high-efficiency filter system. Using a rag soaked in water and wrung until nearly dry, remove any remaining dust. Do not use compressed air or dry brushing to clean the brake assembly.
10. Back off the wheel-bearing adjusting nut about two turns or enough to allow the weight of the hub to be lifted from the wheel bearings.

11. Remove the jam nut, lockwasher, and lockring. See Fig. 1.

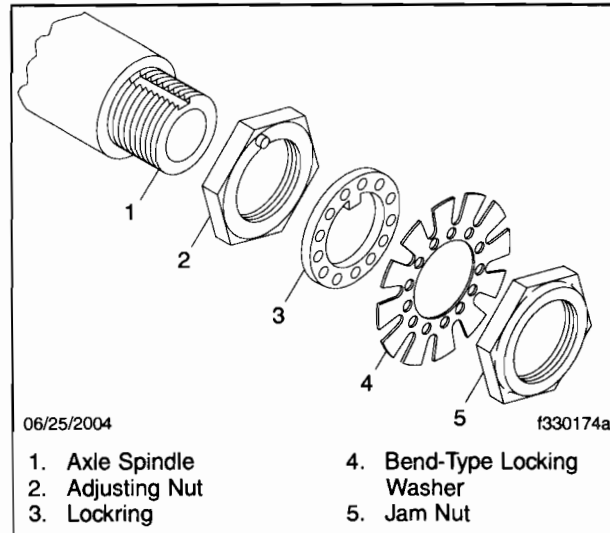

Fig. 1, Four-Piece Wheel-Bearing Retaining System

12. Lift the hub until all weight is removed from the wheel bearings and remove the adjusting nut.
13. Wrap the axle-spindle threads with friction tape to protect them.
14. Move the hub about 1/2 inch (13 mm) to jar loose the outer wheel bearing (allow the hub-only assembly to rest on the axle spindle; be careful not to damage the axle spindle threads).
15. Remove and discard the outer wheel bearing.

CAUTION

On vehicles equipped with WABCO ABS, use care when handling the hubs. The ABS tone wheel is permanently pressed onto the hub and cannot be repaired. The tone wheel and the hub must be replaced as a unit if either is damaged. To prevent damage to the tone wheel, do not drop the hub or lay it down in a way that would damage the tone wheel.

16. Remove the hub from the axle spindle. Be careful not to damage the axle-spindle threads as the assembly is removed.
17. Remove the wheel seal from the hub or the axle spindle, as applicable, and discard it.
18. Remove and discard the inner bearing.
19. Pack the new inner and outer bearings with MBL SHC007 synthetic grease.
20. Install the grease-packed inner bearing in the hub, followed by a new wheel seal.
21. Install the hub assembly on the axle spindle. Be careful to support the hub over the spindle until it is fully seated on spindle, otherwise the hub seal can be damaged.

Recall Campaign

July 2007
FL500A
NHTSA #07V-266

WARNING

Failure to add grease to the wheel hub after the hub has been serviced will cause the wheel bearings to overheat and seize during vehicle operation. Seized bearing rollers can cause sudden damage to the tire or axle, possibly resulting in personal injury due to loss of vehicle control.

22. Install MBL SHC007 grease directly into hub cavity while rotating the hub. Ensure that the grease is evenly distributed around the inside circumference of the hub. Fill the hub to the top level of the outer bearing cup, all the way around the inside of the hub.
23. Install the grease-packed outer bearing, then adjust the wheel bearings as follows:

WARNING

Follow the wheel-bearing adjustment and checking instructions exactly, including the use of a dial indicator to measure wheel-bearing end play. If the wheel-bearing end play is not correct, the wheel bearings could fail. This could cause the loss of the wheel and hub assembly, resulting in an accident causing serious injury or property damage.

IMPORTANT: Be sure there is sufficient clearance between the brake shoe and the brake drum, so brake shoe drag will not interfere with bearing adjustment.

- 23.1 Install and tighten the inner (adjusting) nut 100 lbf·ft (136 N·m) while rotating the wheel hub assembly.
- 23.2 Loosen the nut completely and then tighten it 50 lbf·ft (27 N·m).
- 23.3 Back off the inner nut 135 to 145 degrees, or about 1/3 turn.
- 23.4 Install the locking device (bend-type locking washer and a lockring) and the jam nut. See **Fig. 1**.
Tighten the jam nut 200 to 300 lbf·ft (271 to 407 N·m).

IMPORTANT: Do not adjust the wheel bearings with the wheel mounted on the hub. Bearing end play cannot be accurately adjusted or measured with the wheel mounted on the hub. *You must use a dial indicator to measure the end play.*

- 23.5 With the jam nut installed and tightened, *attach a dial indicator to the hub* and set the point of the indicator in line with the end of the axle spindle. See **Fig. 2**.
- 23.6 If the brakes were used to hold the drum during installation, release them.
Grip the sides of the hub at the 3 o'clock and 9 o'clock positions. Push the hub (and drum, if applicable) to seat the inboard bearing set. Zero the dial indicator.
Grip the sides of the hub at the 3 o'clock and 9 o'clock positions. Pull the hub (and drum, if applicable). Read the dial indicator and note the end play.
Push the hub back in to confirm that the needle of the dial indicator returns to zero.

IMPORTANT: The end play must be between 0.001 and 0.005 inch (0.025 and 0.127 mm). *Use the dial indicator to measure this.* Correct end play is crucial to the life of the wheel bearings.

24. If the wheel-bearing end play is correct, go to the next step.

If the end play is not within the correct range, remove the jam nut and locking device and back off or tighten the inner (adjusting) nut to adjust the end play.

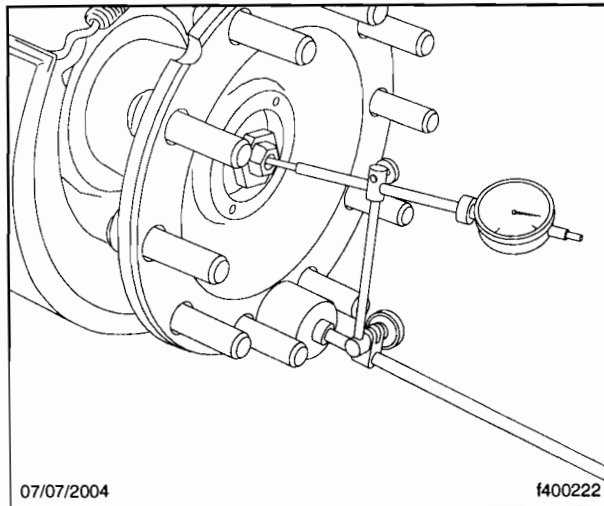

Fig. 2, Using the Dial Indicator

IMPORTANT: Keep the following in mind:

Turning the inner nut one locking hole will change the end play by about 0.005 inch (0.127 mm). If you take the locking off and reverse it, then turn the inner nut to the next hole, this will change the end play by about 0.0025 inch (0.0635 mm).

Install the locking device and jam nut as described earlier and measure the end play, using the dial indicator.

If the end play does not measure between 0.001 and 0.005 inch (0.025 and 0.127 mm), readjust the inner (adjusting) nut.

25. When the dial indicator shows the correct wheel-bearing end play, bend the bend-type locking washer as applicable to lock the jam nut and/or adjusting nut in place.
26. Remove any old grease from inside the hub cap, then fill it half-full with clean MBL SHC007 synthetic grease. Place the hub cap and a new gasket in position and install the washers and capscrews. Tighten the capscrews 20 to 30 lbf-ft (27 to 41 N·m).
27. Repeat the entire procedure on the other side of the vehicle.
28. Install the wheel-and-tire assemblies. See **Group 40** in the applicable vehicle workshop manual for instructions.

⚠ WARNING

If the wheel nuts cannot be tightened to minimum torque values, the wheel studs have lost their locking action, and the wheel hub flange is probably damaged. In this case, replace it with a new wheel hub assembly. Failure to replace the wheel hub assembly when these conditions exist could result in the loss of a wheel or loss of vehicle control and possible personal injury and property damage.

29. Adjust the front axle brakes. For instructions, see **Group 42** in the applicable vehicle workshop manual for instructions.
30. Raise the vehicle, remove the safety stands, then lower the vehicle.
31. Clean a spot on the base label (Form WAR259). Write the recall number, FL500. on a blank, red completion sticker (From WAR260) and attach it to the base label.
32. Remove the chocks.