

DAIMLERCHRYSLER

DaimlerChrysler Corporation

Stephan J. Speth

Director

Vehicle Compliance & Safety Affairs

March 27, 2007

Mr. Daniel Smith
Associate Administrator, Safety Assurance
National Highway Traffic Safety Administration
400 Seventh Street, S.W.
Washington, D.C. 20590

Dear Mr. Smith:

Reference: NHTSA Identification Number 07V-092

Enclosed are representative copies of communications relating to the 2004 through 2006 model year vehicles involved in the referenced recall. DaimlerChrysler expects to notify dealers and owners during the week of April 2, 2007. The exact number of manufactured vehicles in the recall is 326,499.

The involved Vehicle Identification Number range is:

<u>Low</u>	<u>High</u>
4F100001	4F242372
5F500001	5F625710
6F100001	6F194022

(VIN last eight characters) - 4 = 2004 model year; 5 = 2005 model year; 6 = 2006 model year; F = Newark Assembly Plant, Newark Delaware; and the last six digits = sequential number.

This completes DaimlerChrysler's package of information for this recall as required by the Defects Report Regulation.

Sincerely,

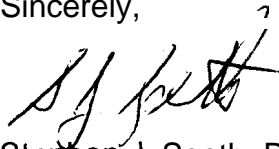

Stephan J. Speth, Director
Vehicle Compliance and Safety Affairs

Enclosure: Dealer and Owner Letter for Recall G07

cc: K.C. DeMeter

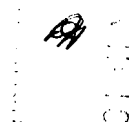

Dealer Service Instructions for:

Safety Recall G07

Test and Reprogram Instrument Cluster

Models

2004-2006 (HB) Dodge Durango

IMPORTANT: Some of the involved vehicles may be in dealer new vehicle inventory. Federal law requires you to complete this recall service on these vehicles before retail delivery. Dealers should also consider this requirement to apply to used vehicle inventory and should perform this recall on vehicles in for service. Involved vehicles can be determined by using the VIP inquiry process.

Subject

Under Certain operating conditions, an integrated circuit in the instrument cluster on about **326,000** of the above vehicles may overheat and result in an instrument panel fire.

Repair

The instrument cluster wiring must be modified, the cluster must be tested, and the Instrument Cluster/Cabin Compartment Node (CCN) must be reprogrammed. Instrument clusters that fail the test must be replaced.

NOTE: The reprogramming procedure in this recall contains a unique additional cluster self diagnostic test that must be performed.

Alternate Transportation

Dealers should attempt to minimize customer inconvenience by placing the owner in a loaner vehicle if inspection determines that instrument cluster replacement is required and the vehicle must be held overnight.

Parts Information

Due to the small number of involved vehicles expected to require an instrument cluster, no parts will be distributed initially. **Instrument clusters should be ordered only after inspection determines that repair is required.** *Very few vehicles are expected to require an instrument cluster.*

Use the following procedure to determine a "Highline" cluster from a "Lowline" cluster.

- "Highline" clusters have silver indicator needle hubs and silver rings around the gauges.
- "Lowline" clusters have white indicator needle hubs and black rings around the gauges.

<u>Model Year</u>	<u>Part Number</u>	<u>Description</u>
2004	56049091AO	Cluster, Instrument - Highline
2004	56049092AO	Cluster, Instrument - Lowline
2005	56049691AJ	Cluster, Instrument - Highline
2005	56049692AJ	Cluster, Instrument - Lowline
2006	56044901AN	Cluster, Instrument - Highline
2006	56044902AN	Cluster, Instrument - Lowline

Dealers must utilize the DealerCONNECT Exchange Order system to order a replacement instrument cluster. The order is transmitted electronically directly to the MOPAR Supplier Shipped Direct (SSD) Department. The SSD department processes orders several times a day and sends them to the DaimlerChrysler Authorized Service Centers. The Service Centers provide an exchange instrument cluster to arrive at the dealership within 24 to 48 hours of the original order.

Parts Information (Continued)

Use the following procedure to order a replacement instrument cluster:

- a. Open a DealerCONNECT session.
- b. From the DealerCONNECT home page, click on the "Parts" tab.
- c. Select "Exchange Order Entry" in the "Order Parts" box.
- d. Type in an order number and then click on "Save & Continue".
- e. Fill in the information requested on the screen, then click "Save".

NOTE: Order cluster as a "Warranty Repair."

- f. Click on "Submit" and then click on " O K on the confirmation box.

Refer to your Warranty Administration Manual for complete details.

Parts Return

The original instrument cluster must be returned.

Clusters ordered via DealerCONNECT Exchange Order Entry system will arrive from the Service Center with two copies of the Authorized Return Service (ARS) pre-paid UPS shipping label in the carton. Be sure to retain one copy for your records and return the other with the old instrument cluster.

NOTE: The old cluster must be returned in the new cluster box. Failure to return the cluster will result in a charge to your parts account.

Special Tools

The following special tools are required to perform this repair:

- CH10090 Cluster Test Harness Leads
- 6932** Connector Terminal Lock Pick
- CH9401* StarSCAN[®] Tool
- CH9801 StarMOBILE[®] Tool
- CH9804 StarMOBILE Vehicle Cable
- CH9404* StarSCAN Vehicle Cable
- CH9409* StarSCAN Documentation Kit
- CH9410* Ethernet Cable (12 ft.)
- CH9412* StarSCAN Software Update Device Kit
- Version 7.03 or higher StarSCAN Software Update CD

* Part of CH9400 kit.

** Part of 8197A kit

NOTE: One Instrument Cluster Test Harness was mailed to each **Chrysler/Jeep/Dodge** dealer free of charge in late March, 2007. The Connector Terminal Lock Pick (#6932) referenced in the repair procedure is part of an essential tool package previously sent to each dealer. Additional Instrument Cluster Test Harnesses and Connector Terminal Lock Picks can be ordered, at dealer expense, by calling Miller Special Tools at **1-800-801-5420** during regular business hours.

Service Procedure**A. Cluster Tests and Wiring Harness Modification**

1. Use the following procedure to verify that the vehicle's dome lights are operating properly:
 - a. Place the instrument cluster panel dimming control in the midpoint of its travel.
 - b. Close all the doors on the vehicle.
 - c. Open the driver's door and the dome light should come on.
 - d. Close the driver's door and the dome light should go out within approximately 45 seconds.
 - If the dome operates normally continue with Step 2 of this procedure.
 - If the dome light does not come on when the door is opened, troubleshoot and repair the dome light circuit as required and repeat Step 1 of this procedure.

NOTE: Also check the vehicle warranty history to determine if the cluster has been replaced recently with a current level part number cluster. Replacing the cluster without modifying the wiring will result in an inoperative dome lamp.

- If the dome light remains on continuously after the door is closed, the cluster must be replaced. Record the mileage, order a new instrument cluster and store the vehicle with the battery disconnected. When the new cluster arrives, continue with Step 3, but skip Step 14 (cluster test with an ohmmeter).

CAUTION: Do not return the vehicle to the customer until the new cluster is installed and wiring modifications have been performed.

2. Record the odometer reading shown on the instrument cluster.
3. Disconnect and isolate the negative battery cable.

WARNING: To avoid personal injury or death, on vehicles equipped with airbags, disable the supplemental restraint system before attempting this repair. Disconnect and isolate the battery negative (ground) cable, then wait two minutes for the system capacitor to discharge before performing further diagnosis or service. This is the only sure way to disable the **supplemental** restraint system. Failure to take the proper precautions could result in accidental **airbag** deployment.

Service Procedure (Continued)

4. Remove the instrument panel knee blocker and knee blocker reinforcement.
5. Remove the brake light switch to prevent losing the adjustment setting.
6. Remove the steering column mounting nuts and lower the steering column.

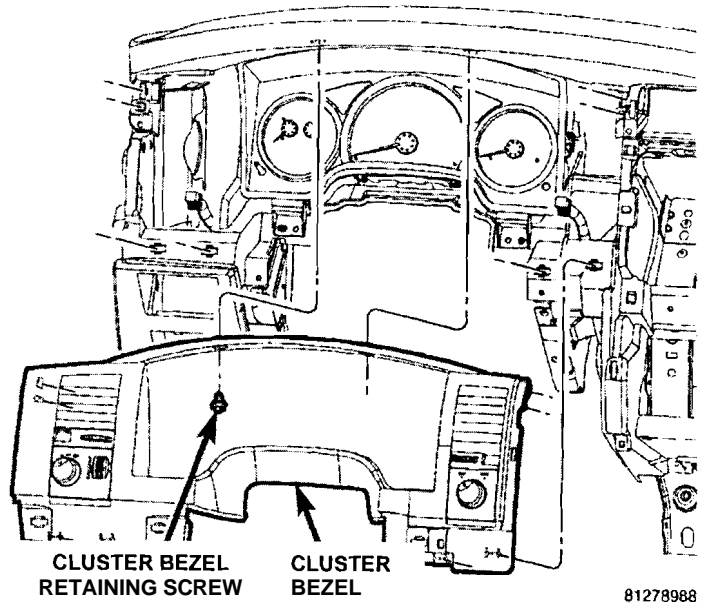

Figure 1

7. Partially remove the center stack bezel and instrument panel end cap.
8. Remove the cluster bezel retaining screws and using a trim stick or equivalent, separate the cluster bezel from the instrument panel (Figure 1).

9. Disconnect the electrical connectors on the back of the cluster bezel and remove the instrument cluster bezel from the instrument panel.

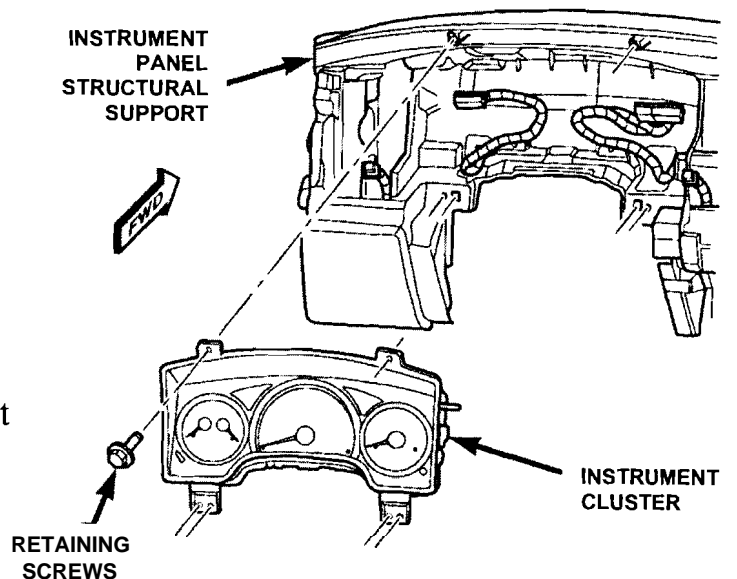

Figure 2

10. Remove the four retaining screws that secure the instrument cluster to the instrument panel structural support (Figure 2).

Service Procedure (Continued)

11. Pull the instrument cluster away from the instrument panel to access and disconnect the instrument panel wire harness connectors from the instrument cluster housing (Figure 3).
12. Remove the instrument cluster from the instrument panel.

CAUTION: Do not leave the instrument cluster in the face-down position for more than 20 minutes as gauge damage may occur.

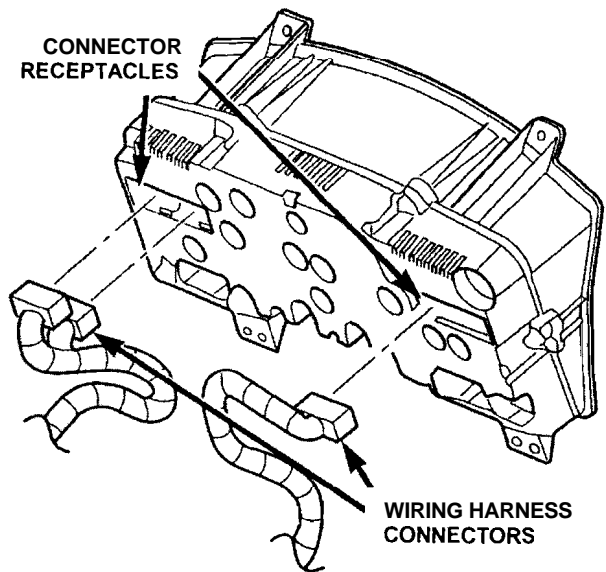

Figure 3

13. Use the following procedure to relocate the yellow (w/orange tracer) wire in cavity number C11 of the white instrument panel cluster connector to the open cavity number C2 of the same connector:

NOTE: The new cluster software **will** reassign the control circuit for the dome lamp to a different pin on the cluster connector. Therefore, the dome lamp wire must be relocated so that the dome lamp will function after this repair is performed.

- a. Lift the secondary wire lock located on the side of the white instrument cluster electrical connector (Figure 4).

NOTE: The secondary wire lock only needs to be lifted approximately 1/8" to release.

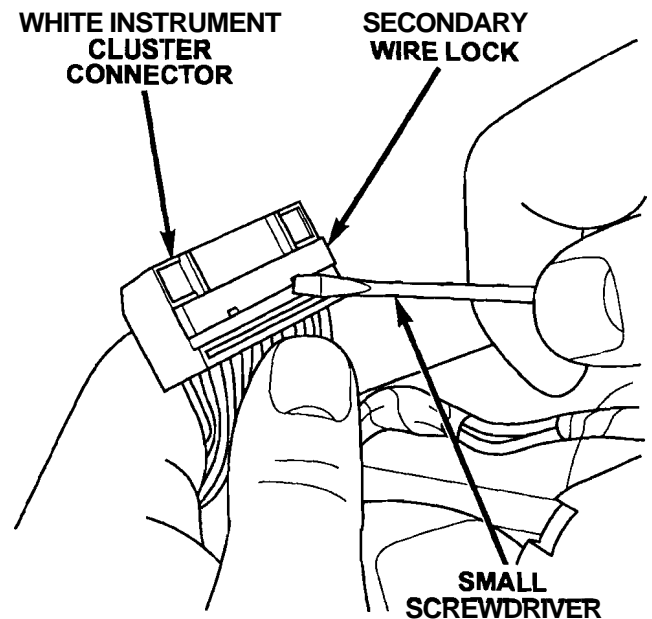

Figure 4

Service Procedure (Continued)

b. Using Special Tool 6932 (part of Special Tool kit 8197A), probe the white instrument cluster electrical connector cavity from the terminal side to release the yellow (w/orange tracer) wire terminal lock (Figure 5 and 6).

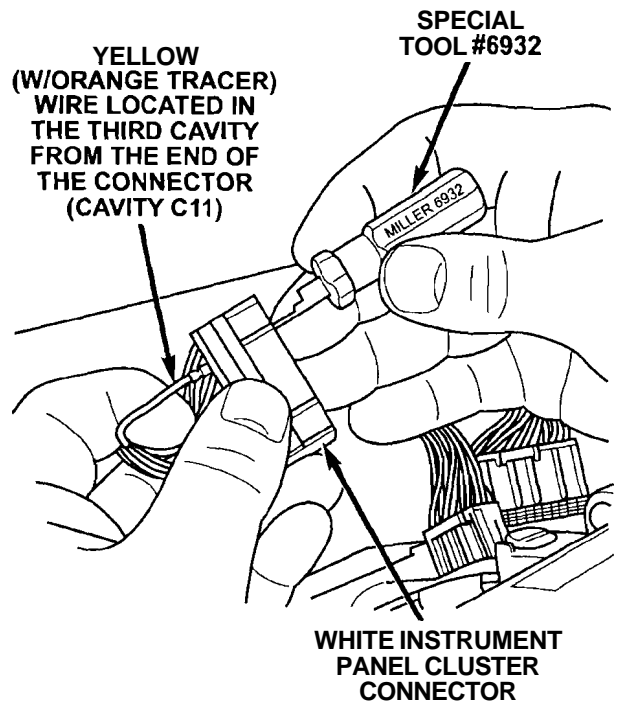

Figure 5

c. With Special tool 6932 inserted into the connector, remove the yellow (w/orange tracer) wire from the white instrument cluster connector (Figure 5 and 6).

d. Install the yellow (w/orange tracer) wire into cavity C2 of the white instrument panel electrical connector (Figure 6). Pull back slightly on the wire to ensure the primary lock is engaged.

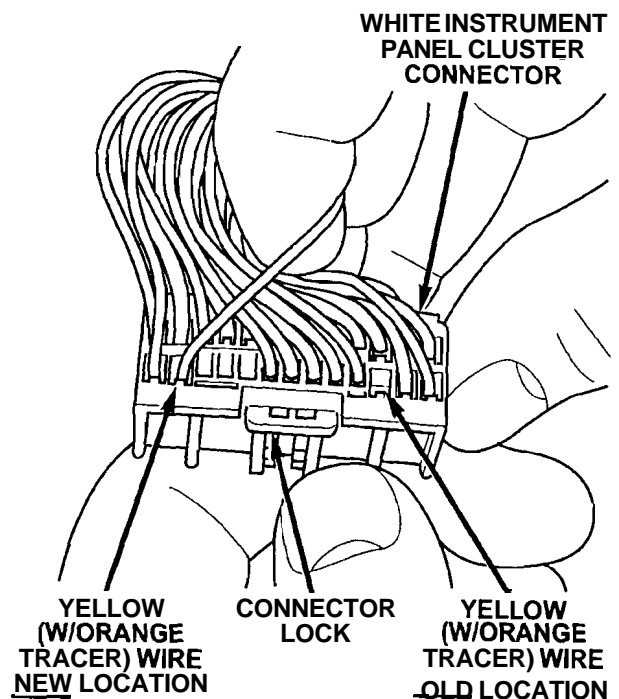

Figure 6

e. Press the secondary wire lock down on the white instrument panel electrical connector until it is flush with the connector body. This will lock the wires into position.

Service Procedure (Continued)

14. If the cluster was not replaced in Step 1 test the cluster using the following procedure:

NOTE: If the instrument cluster has been replaced in Step 1 of this procedure, Step 14 is not required. Continue with Step 15.

a. Place the instrument cluster face down on a clean work surface.

CAUTION: Make sure when the instrument cluster is laying face down on the lens that it is not being damaged or scratched and that it does not remain in this position for more than 20 minutes.

b. Connect the white connector of Special Tool CH10090 to the white instrument cluster connector (Figure 7).

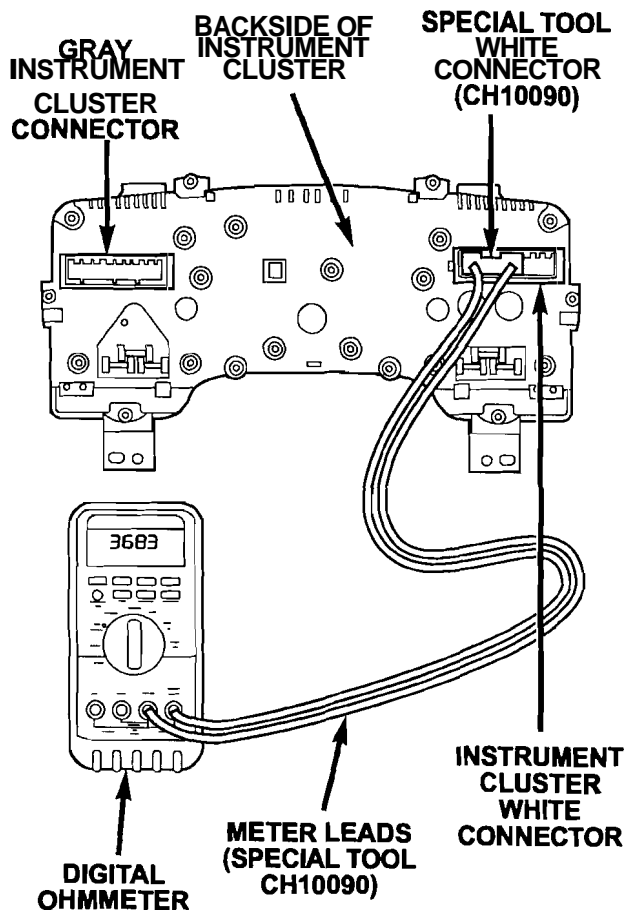

Figure 7

NOTE: Make sure the connector is seated properly in the cluster connector.

c. Connect the wires of Special Tool CH10090 to the ohmmeter terminals (Figure 7).

NOTE: The polarity of the leads must be red to positive and black to common.

Service Procedure (Continued)

d. Read the ohmmeter resistance measurement:

NOTE: Place ohmmeter in the "Auto" range setting if available or in the **10k** range if the ohmmeter requires a manual setting.

- If the resistance reading is more than **2000** Ohms, the cluster is good. Continue with Step 15 of this procedure.

NOTE: An open circuit Ohmmeter reading is considered a good cluster.

- If the resistance reading is less than **2000** Ohms, the cluster must be replaced. Follow the procedure below to replace the instrument cluster:

1. Take the VIN and odometer reading information to the parts department and order a replacement instrument cluster.

CAUTION: The vehicle cannot be returned to the customer until the new cluster is installed. DO NOT reinstall the old cluster into the vehicle.

2. Temporarily install the steering column and brake switch.
3. Connect the battery and park the vehicle until the new cluster arrives
4. When the replacement cluster arrives, place the original cluster in the replacement cluster box and return the original cluster to the parts department.
5. Continue with Step 15 of this procedure.

15. Position the instrument cluster close enough to the instrument panel to connect the instrument cluster wire harness connectors to the connector receptacles on the back of the cluster (Figure 3). Position the instrument cluster into the instrument panel (Figure 2).

16. Connect the negative battery cable.

17. For vehicles that did not have the cluster replaced, reprogram (flash) the CCN module using either the StarSCAN scan tool (Section B) or the StarMOBILE scan tool (Section C) before reassembling the vehicle.

For vehicles that had the cluster replaced, continue with Section D. Install Instrument Cluster

NOTE: Replacement instrument clusters will already contain the latest software and do not require reprogramming.

NOTE: The CCN module reprogramming procedure has an additional cluster test procedure that must be performed as well as a procedure to reset the overhead temperature display.

Service Procedure (Continued)**B. Reprogram the CCN Module Using StarSCAN**

NOTE: The StarSCAN tool must be at version 7.03 or higher before this procedure can be performed. The software release level is visible in the blue header at the top of the StarSCAN screen.

NOTE: Replacement instrument clusters will already contain the latest software and do not require reprogramming.

1. Open the hood and install a battery charger. Verify that the charging rate provides approximately 13.5 volts.
2. Use the following procedure to determine the CCN Control Module software part number:
 - a. Connect the StarSCAN to the vehicle data link connector located under the steering column and turn the ignition key to the " R U N position.
 - b. Power ON the StarSCAN.
 - c. From the StarSCAN Home Screen, select "ECU View".
 - d. From the StarSCAN ECU View Screen, select "CCN" from the list of modules.
 - e. Select "More Options" and then select "ECU Flash".
 - f. Record the part number displayed at the top of the "Flash CCN" screen for later reference.
3. Connect the CH9410 StarSCAN ethernet cable to the StarSCAN and the dealer's network drop.
4. Select "Browse for New File" and follow the on screen instructions.
5. Highlight the calibration and then select "Download to Scantool".
6. Select "Close" after the download is complete, then select "**Back**".
7. Highlight the listed calibration.
8. Select "Update Controller" and follow the screen instructions.

Service Procedure (Continued)

9. When the CCN update is complete, select " O K .
10. Verify the part number (resident flash file) at the top of the screen has updated to the new part number.
11. **Vehicles equipped with overhead temperature display**, place the ignition key in the "Run" position and observe temperature reading at the overhead console display window.
 - 9 If the temperature reading matches approximately ambient temperature, proceed to Step 12.
 - 9 If the temperature reading is -40 degrees, place the ignition key in the "Off" position and disconnect the negative battery cable from the battery for 10 seconds, then reconnect the negative battery cable. This will reset the overhead temperature reading.
12. Perform the following procedure to **initiate the new cluster self diagnostics** for the dome lamp circuit:
 - a. With all other doors closed, open the driver's side door.
 - b. Verify that the dome lamps are "On".
 - c. Turn the ignition to the " RUN position.
 - d. Close the driver's side door.
 - e. Verify that the dome lamp goes off after approximately 3 seconds.
 - f. Turn the ignition to the "OFF" position.
 - e. Repeat steps a. through f. two more times.
 - 9 If the dome lamp operates correctly after three cycles, proceed to Step 13.
 - 9 If the dome lamp stops functioning, the self diagnostics found an additional problem in the cluster that was not detectable with the ohmmeter test previously performed. Replace the cluster assembly.

Service Procedure (Continued)

13. After completing the CCN reprogramming, performing the cluster self diagnostic test and resetting the overhead temperature display, clear all Diagnostic Trouble Codes (DTC's) using the following procedure:
 - a. Return to the "**Main Menu**" (Home Page)
 - b. Select "**System View**"
 - c. Select "**All DTC's**"
 - e. Select "**Clear All Stored DTC's**"
 - f. Follow the screen prompts.
14. Disconnect and remove the StarSCAN and battery charger from the vehicle.
15. Continue with **Section D. Install Instrument Cluster.**

Service Procedure (Continued)C. Reprogram the CCN Module Using StarMOBILE

NOTE: The StarMOBILE tool must be at version **7.03** or higher before this procedure can be performed.

NOTE: Replacement instrument clusters will already contain the latest software and do not require reprogramming.

1. Open the hood and install a battery charger. Verify that the charging rate provides approximately 13.5 volts.
2. Connect the StarMOBILE scan tool to the vehicle data link connector located under the steering column and turn the ignition key to the "RUN" position.
3. Power ON the StarMOBILE scan tool.
4. Connect the CH9410 StarMOBILE scan tool ethernet cable to the StarMOBILE and the dealer's network drop.
5. From the desktop, launch the "StarMOBILE Desktop Client" software.
6. Establish a connection with the StarMOBILE scan tool.
7. Select "Flash Download".
8. Select "Next" and then enter your ID and password.
9. Enter the vehicle information (manually or use the automatic function).
10. Highlight the required flash file and select "Download to Client".
11. Select "BACK" then select "ECU View".
12. Select "CCN".
13. Select "More Options".
14. Select "ECU Flash".

Service Procedure (Continued)

15. Select "**Manage Files**".
16. Highlight downloaded flash file.
17. Select "**Copy to SM Devise**" and then follow the screen prompts.
18. Disconnect the ethernet cable from the StarMOBILE scan tool.
19. Turn off the StarMOBILE scan tool and then restart the scan tool.
NOTE: The StarMOBILE scan tool must be shut down and restarted to unlock the flash.
20. From the "System Status" screen press the "**Exit**" button.
21. From the "Main Menu" select "**Enter Standalone Diagnostic Mode**".
22. Select "**ECU View**" and press the select button.
23. Highlight "**CCN**" and press the select button.
24. Select "**Flash ECU**" and press the select button.
25. Verify the file number on the screen. If correct press the select button and follow the screen prompts.
26. When the flash is complete, press the "OK" button.
27. **Vehicles equipped with overhead temperature display**, place the ignition key in the "Run" position and observe temperature reading at the overhead console display window.
 - 9 If the temperature reading matches approximately ambient temperature, proceed to Step 28.
 - If the temperature reading is -40 degrees, place the ignition key in the "Off" position and disconnect the negative battery cable from the battery for 10 seconds, then reconnect the negative battery cable. This will reset the overhead temperature reading.

Service Procedure (Continued)

28. Perform the following procedure to **initiate the new cluster self diagnostics** for the dome lamp circuit:
 - a. With all other doors closed, open the driver's side door.
 - b. Verify that the dome lamps are "On".
 - c. Turn the ignition to the "RUN" position.
 - d. Close the driver's side door.
 - e. Verify that the dome lamp goes off after approximately 3 seconds.
 - f. Turn the ignition to the "OFF" position.
 - e. Repeat steps a. through f. two more times.
 - If the dome lamp operates correctly after three cycles, proceed to Step 29.
 - If the dome lamp stops functioning, the self diagnostics found an additional problem in the cluster that was not detectable with the ohmmeter test previously performed. Replace the cluster assembly.
29. After completing the CCN reprogramming, performing the cluster self diagnostic test and resetting the overhead temperature display, clear all Diagnostic Trouble Codes (DTC's) using the following procedure:
 - a. Return to the "**Main Menu**" (Home Page)
 - b. Select "**System View**"
 - c. Select "**All DTC's**"
 - e. Select "**Clear All Stored DTC's**"
 - f. Follow the screen prompts.
30. Disconnect the StarMOBILE scan tool and battery charger from the vehicle.
31. Continue with **Section D. Install Instrument Cluster.**

Service Procedure (Continued)**D. Install Instrument Cluster**

1. Install the four screws that secure the instrument cluster to the instrument panel structural support (Figure 2). Tighten the screws to 17 in. lbs. (2 N·m).
2. Position the instrument cluster bezel close enough to the instrument panel to connect the cluster bezel electrical connectors (Figure 8).
3. Position the instrument cluster bezel onto the instrument panel and seat fully.
4. Install the two instrument cluster bezel retaining screws and tighten securely (Figure 1).
5. Install the center stack bezel.
6. Install the instrument panel end cap.
7. Raise the steering column into position and install the mounting nuts. Tighten the nuts to 20 ft. lbs. (28 N·m).
8. Install the brake lamp switch into the brake lamp bracket
9. Install the instrument panel knee blocker reinforcement.
10. Install the knee blocker.
11. Verify brake light operation.

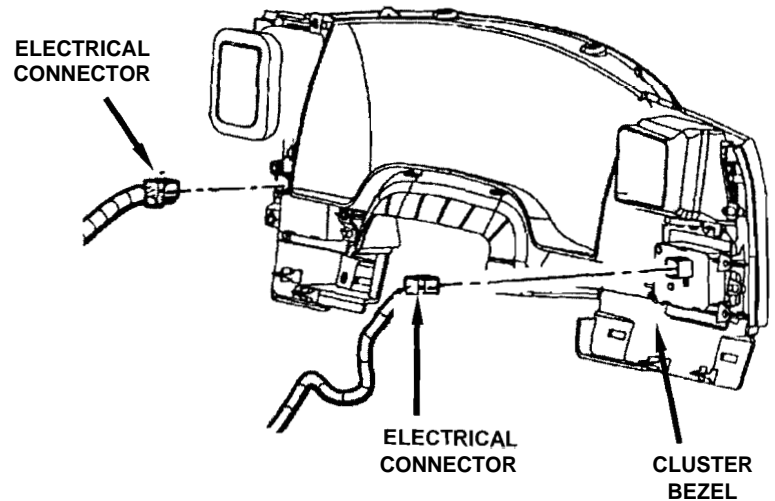
**Figure 8**

Completion Reporting and Reimbursement

Claims for vehicles that have been serviced must be submitted on the DealerCONNECT Claim Entry Screen located on the Service tab. Claims submitted will be used by DaimlerChrysler to record recall service completions and provide dealer payments.

Use one of the following labor operation numbers and time allowances:

	<u>Labor Operation Number</u>	<u>Time Allowance</u>
Perform instrument cluster tests, modify wiring and flash CCN module	08-GO-71-82	1.3 hours
Perform instrument cluster tests, modify wiring and replace the instrument cluster	08-GO-71-83	1.0 hours
Test dome lamp function, modify wiring and replace instrument cluster	08-GO-71-84	0.8 hours

Any subsequent need for a cluster replacement, other than a dome light circuit issue, is covered under the terms of the new vehicle limited warranty.

NOTE: See the Warranty Administration Manual, Recall Claim Processing Section, for complete recall claim processing instructions.

Dealer Notification

All dealers will receive three copies of this dealer recall notification letter by mail. To view this notification on DealerCONNECT, select "Global Recall System" on the Service tab, then click on the description of this notification.

Owner Notification and Service Scheduling

All involved vehicle owners known to DaimlerChrysler are being notified of the service requirement by first class mail. They are requested to schedule appointments for this service with their dealers. A generic copy of the owner letter is attached.

Enclosed with each owner letter is an Owner Notification postcard to allow owners to update our records if applicable.

Vehicle Lists, Global Recall System, VIP and Dealer Follow Up

All involved vehicles have been entered into the DealerCONNECT Global Recall System (GRS) and Vehicle Information Plus (VIP) for dealer inquiry as needed.

GRS provides involved dealers with an updated VIN list of their incomplete vehicles. The owner's name, address and phone number are listed if known. Completed vehicles are removed from GRS within several days of repair claim submission.

To use this system, click on the "**Service**" tab and then click on "**Global Recall System.**" Your dealer's VIN list for each recall displayed can be sorted by: those vehicles that were unsold at recall launch, those with a phone number, city, zip code, or VIN sequence.

Dealers must perform this repair on all unsold vehicles *before* retail delivery. Dealers should also use the VIN list to follow up with all owners to schedule appointments for this repair.

Recall VIN lists may contain confidential, restricted owner name and address information that was obtained from the Department of Motor Vehicles of various states. Use of this information is permitted for this recall only and is strictly prohibited from all other use.

Additional Information

If you have any questions or need assistance in completing this action, please contact your Service and Parts District Manager.

Customer Services Field Operations
DaimlerChrysler Corporation

DAIMLERCHRYSLER

SAFETY RECALL G07 – TEST AND REPROGRAM INSTRUMENT CLUSTER

Dear: (Name)

This notice is sent to you in accordance with the requirements of the National Traffic and Motor Vehicle Safety Act.

DaimlerChrysler Corporation has decided that a defect, which relates to motor vehicle safety, exists in some **2004 through 2006 model year Dodge Durango vehicles.**

The problem is... Under certain operating conditions, an integrated circuit located in the instrument cluster of your vehicle (VIN: xxxxxxxxxxxxxxxxxxxx) may overheat and result in an instrument panel fire.

What your dealer will do... DaimlerChrysler will repair your vehicle free of charge (parts and labor). To do this, your dealer will modify the instrument cluster wiring, test the instrument cluster and replace it if necessary. Instrument clusters that do not require replacement will be reprogrammed. The work will take about 1½ hours to complete. However, additional time may be necessary depending on service schedules.

What you must do to ensure your safety... Simply contact your dealer right away to schedule a service appointment. **Remember to bring this letter with you to your dealer.**

If you need help... If you have questions or concerns which your dealer is unable to resolve, please contact DaimlerChrysler at 1-800-853-1403.

Please help us update our records, by filling out the attached prepaid postcard, if any of the conditions listed on the card apply to you or your vehicle.

If you have already experienced this condition and have paid to have it repaired, you may send your original receipts and/or other adequate proof of payment to the following address for reimbursement: DaimlerChrysler P.O. Box 4639 Oak Ridge, TN 37831, Attention: Reimbursement.

If your dealer fails or is unable to remedy this defect without charge and within a reasonable time, you may submit a written complaint to the Administrator, National Highway Traffic Safety Administration, 400 Seventh Street, S.W., Washington, DC 20590, or call the toll-free Vehicle Safety Hotline at 1-888-327-4236 (TTY 1-800-424-9153), or go to <http://www.safercar.gov>.

We're sorry for any inconvenience, but we are sincerely concerned about your safety. Thank you for your attention to this important matter.

Customer Services Field Operations
DaimlerChrysler Corporation
Notification Code G07

*Buckle up
for Safety!*

Note to lessors receiving this recall: Federal regulation requires that you forward this recall notice to the lessee within 10 days.