



RECALL CAMPAIGN

NHTSA #O7V-005/ T.C. #07-005

Job Code #9901072

Requires parts to be ordered from Jayco for every unit.

Subject:	Hitch bolts loosening
Units Affected:	All Seneca and Greyhawk motorhomes built on Kodiak chassis
Action Required:	Remove original hitch hardware and replace with higher grade bolts.
Job Operation Code:	9901072
Series Code:	N/A
Flat Rate Time:	1.0 hrs.
Kit Part Number:	0700052
Tools Required:	1/2" drive 3/4" socket, ratchet, 1/2" drive extension, 1/2" drive 7/8" socket, 7/8" wrench, and 1/2" drive torque wrench (up to 200 ft/lbs min)
Additional Requirements:	N/A

Instructions

1. Remove one of the 1/2" carriage bolts from the hitch.
2. Insert a new 14MM bolt from the hardware kit into a new metal plate.
3. Insert the new 14MM bolt/plate down through the frame rail.

N NOTE: Some holes may need to be enlarged to accommodate the 14MM bolt.

4. Place a new plate, flat washer, lock washer and nut on the bottom side of the hitch. Hand tighten.
5. Repeat steps 1-4 for the other three-(3) bolts.
6. Torque all new hardware to 130 – 150 ft/lbs
7. Discard all original hardware.
8. Affix the decal supplied on the back bumper right next to the existing towing decal.
9. Educate customer on information listed on the customer sign off form.

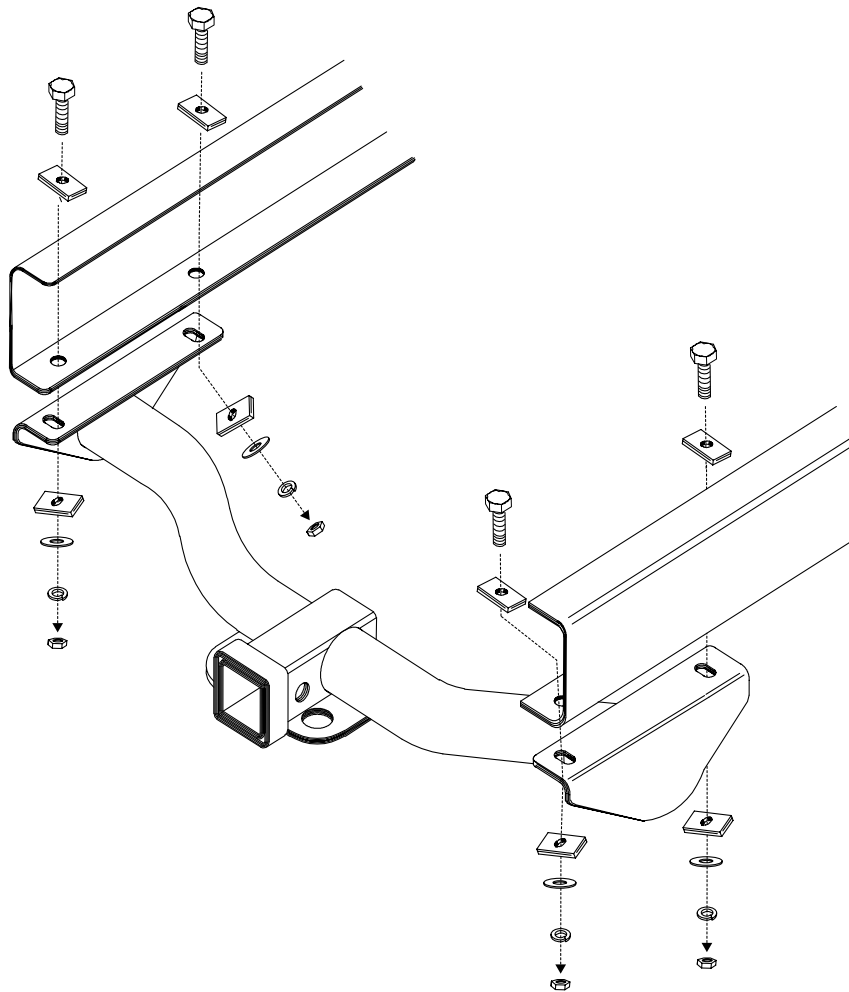
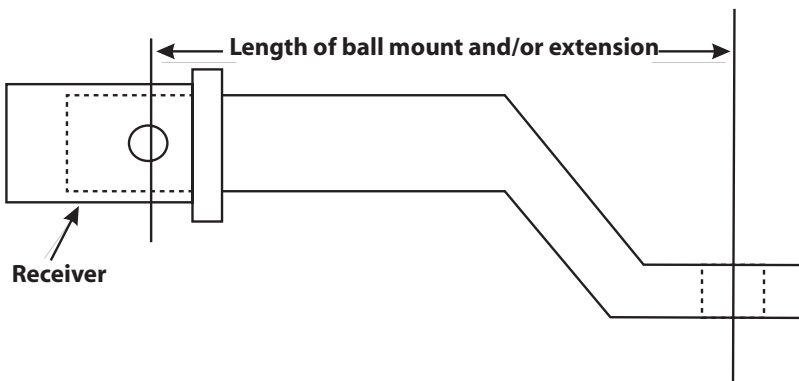

Fig. 1

Confirmation of Extended Ball Mount Limitations

The recall on the hitch has been completed. I understand that the towing capacity of my motorhome is the difference between the GCWR (Gross Combined Weight Rating) and the actual loaded weight of my motorhome and not what is labeled on the hitch. I have been notified of and understand the restrictions for towing behind my Jayco motorhome using a ball mount and/or extensions; understanding that the total length should not exceed 18". I confirm the dealer has installed the warning decal on the hitch of my motorhome. I understand if I choose to use a ball mount and/or extensions, exceeding the total length of 18", this may void the warranty on my Jayco motorhome and potentially cause damage to the hitch, motorhome and any trailer being towed. I understand if any damages occur from the use of a ball mount and/or extensions that exceeds the total length of 18", repairs to any such damage will be at my expense.



Owner Name (Print)

Owner Signature

Date

Jayco Serial number

Dealer Representative Name (Print)

Dealer Representative Signature

Date



NOTE: This document is **required** to be signed by both the Owner of the motorhome and the Dealer Representative along with the Jayco serial number. This signed document is **required** to be submitted by the servicing dealer, with the recall claim for reimbursement. Any information missing may cause the recall claim to be denied.

**Jayco Service / Parts
Recall Order Form
Fax (800) 825-8409**



**Kodiak Chassis Hitch Bolts
Job Code #9901072
Recalls #O7V-005
T.C. #07-005**

Dealer Name: _____	Recall Account: 2292000	Date: _____
Dealer Account Number: _____	Phone: _____	Fax: _____
Ship To: _____	P.O. #: _____	
	Date Shipped _____	
Attn: _____	Ship Via _____	

9901072_KodiakChassisHitchBoltsOrderForm.cdr

**Each unit's serial number MUST be recorded
when ordering this recall kit.**

Quantity Ordered	Quantity Shipped	Serial Number of Unit (Last 8 Digits)	Part Number	U/M	Unit Price
		<input type="text"/>	0700052	EA	N/C
		<input type="text"/>	0700052	EA	N/C
		<input type="text"/>	0700052	EA	N/C
		<input type="text"/>	0700052	EA	N/C
		<input type="text"/>	0700052	EA	N/C
		<input type="text"/>	0700052	EA	N/C
		<input type="text"/>	0700052	EA	N/C
		<input type="text"/>	0700052	EA	N/C
		<input type="text"/>	0700052	EA	N/C

**THESE PARTS CAN ONLY BE ORDERED USING THIS FORM.
YOU CAN NOT ORDER THIS THROUGH EMPART.**