

# DAIMLER

Daimler Trucks North America  
Nasser Zamani  
Senior Manager  
Compliance and Regulatory Affairs

October 3, 2008

Dan Smith  
Associate Administrator for Vehicle Safety  
National Highway Traffic Safety Administration  
1200 New Jersey Avenue S.E.  
Washington D.C. 20590



## Re: Defect Information Report – Supplemental Report No. 5 07V-343, FL-509, ZF 8018 Steering Gear Spacer, Phase 3

Mr. Smith

In accordance with Part 573 of Title 49 of the Code of Federal Regulations, Daimler Trucks North America LLC herewith submits supplemental defect information to amend the expected owner notification date for the third phase of this recall due to parts availability.

**(c)(8) Dealer Notification:** Dealer notification for Phase 3 will be completed December 31, 2008.

**Owner Notification Date:** Owner notification for Phase 3 will be completed December 31, 2008.

Please contact me if you have any questions.

Sincerely yours,

A handwritten signature in black ink that reads "Nasser Zamani".

Nasser Zamani

Cc: Michael Mason, CAL-OSHA  
Certified Mail# 7004 2890 0004 1202 0799

A Daimler Company

Daimler Trucks North America LLC  
4747 N. Channel Avenue  
Portland OR 97217-7699  
503-745-6910 Phone  
503-745-5544 Fax  
NasserZamani@Daimler.com

**Daimler Trucks  
North America LLC**

Daimler Trucks North America LLC  
P.O. Box 4090  
Portland, OR 97208-4090  
800.547.0712 Phone  
503.745.9009 Fax

**December 2008  
FL509 -- Phase 3  
NHTSA #07V-343  
TC #07-252**

**Recall Notification  
Subject: ZF Lenksysteme 8018 Steering Gears**

Daimler Trucks North America has begun notifying its dealers and customers of a safety related defect that exists in certain chassis manufactured by Freightliner Custom Chassis Corporation and delivered to your company. A remedy without charge is now available, and owners may take their vehicle to a Daimler Trucks North America-authorized service facility to have the recall performed. The Recall Bulletin, which includes a representative copy of the owner notification and dealer work instructions, and a list of potentially affected vehicles delivered to you are attached for your information.

Your company may have an obligation to notify its dealers, distributors, and customers of this recall under Title 49 Code of Federal Regulations Part 577.13 and/or Motor Vehicle Safety Act Section 10(1).

If you have questions or need further information, please contact the Warranty Campaigns Department at (800) 547-0712, 7:00 a.m. to 4:00 p.m. Pacific Time, Monday through Friday, e-mail address [DTNA.Warranty.Campaigns@Daimler.com](mailto:DTNA.Warranty.Campaigns@Daimler.com).

WARRANTY CAMPAIGNS DEPARTMENT  
Enclosure

## Subject: ZF Lenksysteme 8018 Steering Gears

**Models Affected: Specific Freightliner Custom Chassis VCL, XB, and XC motorhome chassis manufactured between June 13, 2002, and June 13, 2007, with certain independent front suspension assemblies with ZF Lenksysteme 8018 steering gears.**

### General Information

Daimler Trucks North America LLC, on behalf of its wholly owned subsidiary, Freightliner Custom Chassis Corporation, has decided that a defect that relates to motor vehicle safety exists on the vehicles mentioned above.

There are approximately 6,000 vehicles involved in this campaign.

Certain ZF Lenksysteme model 8018 steering gears may have been assembled with the incorrect recirculating ball spacer; this may allow the recirculating balls to escape their circuit. If this happens, the operator may notice that higher steering wheel inputs are required or the need for more steering wheel adjustments while driving in a straight line in combination with metallic cracking noises prior to a loss of steering. A loss of steering may result in a possible vehicle crash.

Steering gears will be inspected for certain manufacturing date codes and mileage at the time of inspection. Gears assembled during the affected periods and in a certain mileage range will be replaced.

NOTE: All phases of FL509 are now active – FL509A (1,500 vehicles), FL509B (2,000 vehicles), and FL509C (2,800 vehicles). Please perform the recall when ServicePro shows it is open for the specific vehicle.

**REVISION:** FL509C has now been activated. FL509B and C include the additional mileage inspection step. The FL509A inspection is unchanged and is of the date code only.

### Additional Repairs

Dealers must complete all outstanding recall and field service campaigns prior to the sale or delivery of a vehicle. A Dealer will be liable for any progressive damage that results from its failure to complete campaigns before sale or delivery of a vehicle.

Owners may be liable for any progressive damage that results from its failure to complete campaigns within a reasonable time after receiving notification.

### Work Instructions

Please refer to the attached work instructions. Prior to performing the campaign, check the vehicle for a completion sticker (Form WAR260).

### Replacement Parts

Replacement kits are now available and can be obtained by ordering the kit number(s) listed below from your facing Parts Distribution Center.

If our records show your dealership has ordered any vehicles involved in campaign number FL509A-C, a list of the customers and vehicle identification numbers will be available on AccessFreightliner.com. Please refer to this list when ordering parts for this recall.

# Recall Campaign

Daimler Trucks  
North America LLC

December 2008  
FL509A-C  
NHTSA #07V-343  
SECOND REVISED NOTICE

Table 1 - Replacement Parts for FL509

Campaign Number	Kit Number	Part Description	Part Number	Qty. per Kit	Suggested Wholesale*
FL509A-C	25-FL509-000	Steering Gear and Pitman Arm Assembly	8018 974 103	1 ea	\$841.02 U.S. \$841.02 CAN
		Completion Sticker	WAR260	1 ea	

\* Please charge all Direct Warranty Customers the above-listed price for the kit, as they are authorized to perform their own Recalls.

Table 1

## Removed Parts

Please follow Warranty Failed Parts Tracking shipping instructions for the disposition of all removed parts.

## Labor Allowance

Table 2 - Labor Allowance

Campaign Number	Procedure	Time Allowed (hours)	SRT Code	Damage Code
FL509A-C	Inspect steering gear date code (includes mileage inspection for FL509B and FL509C)	0.2	996-0738A	000-Inspected
	Inspect steering gear and replace steering gear/pitman arm assembly	4.5	996-0738B	000-Modifiedx

Table 2

**IMPORTANT:** When the recall has been completed, locate the base completion label in the appropriate location on the vehicle, and attach the red completion sticker provided in the recall kit (Form WAR260). If the vehicle does not have a base completion label, clean a spot on the appropriate location of the vehicle and first attach the base completion label (Form WAR259). If a recall kit is not required or there is no completion sticker in the kit, write the recall number on a blank sticker and attach it to the base completion label.

## Claims for Credit

You will be reimbursed for your parts, labor, and handling by submitting your claim through the Warranty system within 30 days of completing this campaign. Please reference the following information in QuickClaim®:

- Claim type is **Recall**.
- In the FTL Authorization field, enter the campaign number and appropriate condition code (e.g. **FL509A, FL509B, etc.**).
- In the Primary Failed Part Number field, enter **25-FL509-000**.
- In the Parts field, enter the appropriate kit number(s) as shown in the Replacement Parts Table.
- In the Labor field, first enter the appropriate SRT from the Labor Allowance Table. For administrative time, enter SRT 939-0010A for 0.4 hours for RVs.
- For **FL509B** and **FL509C**, note the vehicle's mileage in the claim comments.
- All phases of FL509 are now active – FL509A (1,500 vehicles), FL509B (2,000 vehicles), and FL509C (2,800 vehicles). Please perform the recall when ServicePro shows it is open for the specific vehicle.

December 2008  
FL509A-C

NHTSA #07V-343

**SECOND REVISED NOTICE**

- **Reimbursement for Prior Repairs.** When a customer asks about reimbursement, please do the following.
  - Accept the documentation of the previous repair.
  - Make a brief check of the customer's paperwork to see if the repair may be eligible for reimbursement. (See the "Copy of Owner Letter" section of this bulletin for reimbursement guidelines for this recall.)
  - Contact the Warranty Campaigns Department for a decision and authorization number.
  - Include the approved amount on your claim in sublet/outside purchases.
  - In the claim story, first note the authorization number and that the claim includes a reimbursement request.
  - Retain the documentation and provide it to Warranty Campaigns or Claims Processing if requested.
  - When your claim is paid, reimburse the customer the appropriate amount.

**IMPORTANT:** ServicePro® must be viewed prior to performing the recall to ensure the vehicle is involved and the campaign has not been previously completed. Also, check for a completion sticker prior to beginning work.

Contact the Warranty Campaigns Department at (800) 547-0712, from 7:00 a.m. to 4:00 p.m. Pacific Time, Monday through Friday, Web inquiry at [AccessFreightliner.com](http://AccessFreightliner.com) / Support / My Tickets and Submit an Inquiry, or the Customer Assistance Center at (800) 385-4357, after normal business hours, if you have any questions or need additional information.

To return excess kit inventory related to this campaign, U.S. dealers must submit a Parts Authorization Return (PAR) to the Memphis PDC. Canadian dealers must submit a PAR to their facing PDC. All kits must be in resalable condition. PAR requests must include the original purchase invoice number.

The letter notifying vehicle owners is included for your reference.

Please note that the National Traffic and Motor Vehicle Safety Act, as amended (Title 49, United States Code, Chapter 301), requires the owner's vehicle(s) be corrected within a reasonable time after parts are available to you. The Act states that failure to repair a vehicle within 60 days after tender for repair shall be prima facie evidence of an unreasonable time. However, circumstances of a particular situation may reduce the 60 day period. Failure to repair a vehicle within a reasonable time can result in either the obligation to (a) replace the vehicle with an identical or reasonably equivalent vehicle, without charge, or (b) refund the purchase price in full, less a reasonable allowance for depreciation. The Act further prohibits dealers from selling a vehicle unless all outstanding recalls are performed. Also, any lessor is required to send a copy of the recall notification to the lessee within 10 days.

# Recall Campaign

Daimler Trucks  
North America LLC

December 2008  
FL509A-C  
NHTSA #07V-343  
SECOND REVISED NOTICE

## Copy of Letter to Owner

### Subject: ZF Lenksysteme 8018 Steering Gears

This notice is sent to you in accordance with the requirements of the National Traffic and Motor Vehicle Safety Act. This notice is also sent in accordance with the Canadian Motor Vehicles Safety Act.

Daimler Trucks North America LLC, on behalf of its wholly owned subsidiary, Freightliner Custom Chassis Corporation, has decided that a defect that relates to motor vehicle safety exists on specific Freightliner Custom Chassis VCL, XB, and XC motorhome chassis manufactured between June 13, 2002, and June 13, 2007, with certain independent front suspension assemblies with ZF Lenksysteme 8018 steering gears.

Certain ZF Lenksysteme model 8018 steering gears may have been assembled with the incorrect recirculating ball spacer; this may allow the recirculating balls to escape their circuit. If this happens, the operator may notice that higher steering wheel inputs are required or the need for more steering wheel adjustments while driving in a straight line in combination with metallic cracking noises prior to a loss of steering. A loss of steering may result in a possible vehicle crash.

Steering gears will be inspected for certain manufacturing date codes and mileage at the time of inspection. Gears assembled during the affected periods and in a certain mileage range will be replaced.

Parts are now available for authorized dealers to order. Contact your authorized dealer to arrange to have your vehicle(s) inspected and to assure that parts are available at the dealer, if they are needed. To locate a dealer, search online at [www.FreightlinerTrucks.com](http://www.FreightlinerTrucks.com) or contact the Warranty Campaigns Department for assistance.

When you contact your dealer, refer to campaign number **FL509A-C**. The inspection will take approximately half an hour. If a steering gear replacement is needed, once kit(s) are received at the dealership, it will take approximately four hours. The recall will be performed at no charge to you.

**IMPORTANT:** When the Recall has been completed, please ensure that a label has been affixed to your vehicle referencing **FL509A-C**.

If you do not own the vehicle that corresponds to the identification number(s) which appears on the Recall Notification, please return the notification to the Warranty Campaigns Department with any information you can furnish that will assist us in locating the present owner. If you have leased this vehicle, Federal law requires that you forward this notice to the lessee within 10 days. If you are a subsequent stage manufacturer, Federal law requires that you forward this notice to your distributors and retail outlets within five working days. If you have paid to have this recall condition corrected prior to this notice, you may be eligible to receive reimbursement. Please see the reverse side of this notice for details.

If you are not able to have the defect remedied without charge and within a reasonable time, which is not longer than 60 days after you tender the vehicle for repair, please contact the Warranty Campaigns Department at (800) 547-0712, 7:00 a.m. to 4:00 p.m. Pacific Time, Monday through Friday, e-mail address [WarrantyCampaigns@freightliner.com](mailto:WarrantyCampaigns@freightliner.com), or the Customer Assistance Center at (800) FTL-HELP or (800) STL-HELP, after normal business hours. You may also wish to submit a complaint to the Administrator, National Highway Traffic Safety Administration, 1200 New Jersey Avenue, SE., Washington, DC 20590; or call the Vehicle Safety Hotline at (888) 327-4236 (TTY: 800-424-9153); or to <http://www.safercar.gov>. If your vehicle is involved in the Canadian portion, you may wish to notify Transport Canada, ASFAD, Place de Ville Tower C, 330 Sparks Street, Ottawa, ON K1A 0N5, or phone (800) 333-0510.

We regret any inconvenience this action may cause but feel certain you understand our interest in motor vehicle safety.

WARRANTY CAMPAIGNS DEPARTMENT

Enclosure

## Reimbursement to Customers for Repairs Performed Prior to Recall

If you have already **paid** to have this recall condition corrected you may be eligible to receive reimbursement.

Requests for reimbursement may include parts and labor. Reimbursement may be limited to the amount the repair would have cost if completed by an authorized Freightliner LLC dealer. The following documentation must be presented to your dealer for consideration for reimbursement.

Please provide original or clear copies of all receipts, invoices, and repair orders that show:

- The name and address of the person who paid for the repair.
- The Vehicle Identification Number (VIN) of the vehicle that was repaired.
- What problem occurred, what repair was done, when the repair was done.
- Who repaired the vehicle.
- The total cost of the repair expense that is being claimed.
- Proof of payment for the repair (such as the front and back of a cancelled check or a credit card receipt).

Reimbursement will be made by check from your Freightliner LLC dealer.

Please speak with your Freightliner LLC authorized dealer concerning this matter.

December 2008  
FL509A-C  
NHTSA #07V-343  
SECOND REVISED NOTICE

## Work Instructions

### Subject: ZF Lenksysteme 8018 Steering Gears

**Models Affected:** Specific Freightliner Custom Chassis VCL, XB, and XC motorhome chassis manufactured between June 13, 2002, and June 13, 2007, with certain independent front suspension assemblies with ZF Lenksysteme 8018 steering gears.

NOTE: All phases of FL509 are now active – FL509A (1,500 vehicles), FL509B (2,000 vehicles), and FL509C (2,800 vehicles). Please perform the recall when ServicePro shows it is open for the specific vehicle.

REVISION: FL509C has now been activated. FL509B and C include the additional mileage inspection step. The FL509A inspection is unchanged and is of the date code only.

### Inspection Procedures

#### Manufacturing Date Code Inspection

1. Check the base label (Form WAR259) for a completion sticker for FL509 (Form WAR260) indicating this work has been done. The base label is usually located on the front wall under the dash in motor homes. If a sticker for FL509 is present, nothing further needs to be done. If a sticker is not present, go to the next step.
2. Shut down the engine, set the parking brake, and chock the tires.
3. Check the date code on the data plate of the steering gear. See **Fig. 1**.
  - 3.1 If the date code is 250407 or more, nothing further needs to be done. Go to Step 4.
  - 3.2 If the date code is less than 250407:  
If the vehicle is in FL509A, go to "Steering Gear Replacement."  
If the vehicle is in FL509B or FL509C, go to "Mileage Inspection."
4. Clean a spot on the base label, write the recall number, FL509, on a blank completion sticker, and attach it to the base label.
5. Remove the chocks from tires.

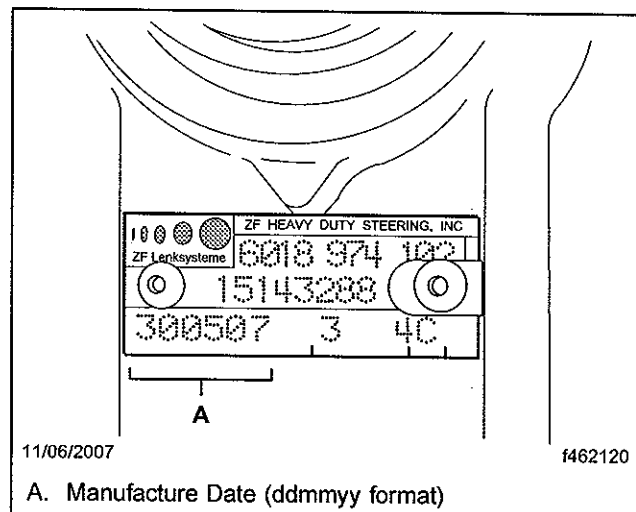

Fig. 1, Data Plate Identification

## Mileage Inspection

NOTE: The mileage inspection applies to vehicles in FL509B and FL509C. The mileage inspection does not apply to vehicles in FL509A.

1. Check the odometer for the vehicle's current mileage. Include the mileage in the recall claim comments.
2. If the current mileage is 15,000 miles or less, go to "Steering Gear Replacement."

If the current mileage is more than 15,000 miles, clean a spot on the base label, write the recall number, FL509, on a blank completion sticker, and attach it to the base label.

## Steering Gear Replacement

NOTE: Please save and reuse the kit shipping container to return the removed steering gear assembly.

1. Raise and support the vehicle so there is 12 inches (30 cm) clearance from the ground. Position jack stands under the frame rails to support the vehicle.
  2. Remove the tie-rods.
    - 2.1 Remove the cotter pins and loosen the tie-rod end retaining nuts on the left and right sides. Leave the nut loosely attached.
- IMPORTANT: Do not use a pry-bar or pickle fork to remove the tie-rod end, this will damage the seal and require replacement.
- 2.2 Use a two-arm gear puller to press the tie-rod end ball stud out of the steering arm taper. Disconnect and set the tie rod end aside.
  3. Bleed the steering gear according to shop practice. Mark and disconnect the pressure and return hoses from the steering gear.
  4. Disconnect the intermediate shaft.
    - 4.1 Remove the pinch bolt from the U-joint of the intermediate shaft.
    - 4.2 Spread the joint slightly by using a screwdriver, tap, or punch in the slot to increase the gap.
    - 4.3 Slide the U-joint forward and out of the way.

NOTE: The pitman arm must be removed assembled to the steering gear output shaft. It is optional to leave the tie-rods attached to the pitman arm and remove the entire assembly at one time. You may also remove the inner tie-rod end from the pitman arm at this time via the two-arm gear puller used for the outer tie-rod ends.

5. Remove the steering gear.
    - 5.1 Using a 1-3/16 impact socket, loosen the four mounting bolts. See **Fig. 2**.
- IMPORTANT: Use two assistants while performing the following procedures.
- 5.2 Remove three nuts, leaving the centermost assembled in order to prevent the steering gear from falling.
  - 5.3 Position 1 x 4 boards (as needed) across the lower control arms, and use a transmission jack to support and receive the gear when it's disconnected. Remove the last nut, lower the gear, and remove to one side.

# Recall Campaign

Daimler Trucks  
North America LLC

December 2008  
FL509A-C  
NHTSA #07V-343  
SECOND REVISED NOTICE

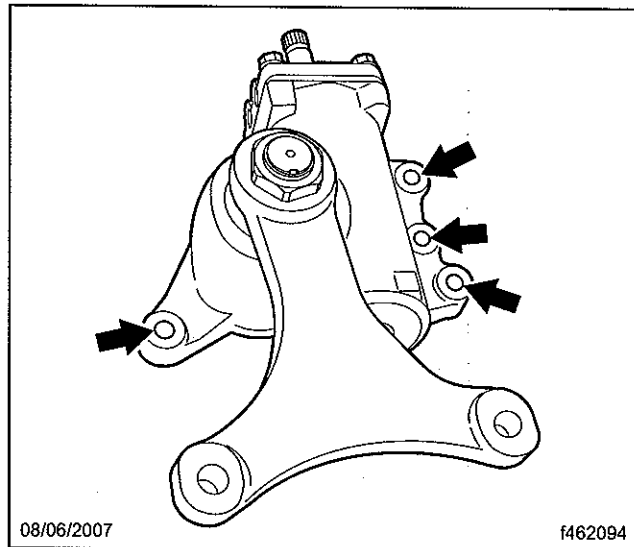

Fig. 2, Steering Gear Mounting Bolts

6. Install the new steering gear.  
**IMPORTANT:** Use two assistants while performing the following procedure.
    - 6.1 Position the new steering gear and pitman arm below its assembled position.
    - 6.2 Using a transmission jack, lift the gear into place, piloting on the mounting bolts, then quickly thread at least one nut into place to prevent the gear from falling.
    - 6.3 Install all remaining nuts, then tighten all four nuts 378 to 462 lbf-ft (18 to 22 N·m).
    - 6.4 Connect the pressure and return hoses to the steering gear.
  7. Connect the intermediate shaft.
    - 7.1 Slide the intermediate shaft U-joint onto the steering gear input shaft.
    - 7.2 Install a new pinch bolt in the U-joint, then install a new locknut on the pinch bolt and tighten the locknut 55 to 65 lbf-ft (75 to 88 N·m)
    - 7.3 Apply white Torque Seal F-900 to the exposed pinch-bolt thread and to the locknut.
  8. Install the tie-rod.
    - 8.1 Insert the tie-rod end ball into the steer arm taper. Connect the tie-rod end.  
**IMPORTANT:** Before tightening tie-rod end fasteners, coat the tie-rod end ball with 15/40 oil.
    - 8.2 Tighten the outer tie-rod retaining nuts on the left and right sides. Tighten to 184 lbf-ft (250 N·m).
    - 8.3 Install the cotter pins
- NOTE:** Poppets are preset, there is no poppet valve adjustment needed.
9. Clean a spot on the base label and attach a completion sticker for Recall FL509.
  10. Remove the chocks from the tires.