

August 7, 2007

«Customer»  
«attention»  
«address»  
«c», «s» «zip»

**SUBJECT: MCI F3500 STEERING ARM IDLER BRACKET RECALL**

Ref.: NHTSA # 07V-191  
TRANSPORT CANADA # 07-146  
MCI Service Bulletin 279C

Attention Owner:

This notice is sent to you in accordance with the National Traffic and Motor Vehicle Safety Act and with the Canadian Motor Vehicle Safety Act - Notice of Safety Defects. Motor Coach Industries, Inc. ("MCI") has decided that a defect which relates to motor vehicle safety exists on certain model year 2002 – 2003 F3500 model coaches, which could result in a crash.

In February 2007, MCI received notice of a possible defect related to steering control on unit 90006, a 2002 MCI model F3500C. MCI conducted an inspection of the front steering system, coach frame, and front cross brace. MCI observed that where the steering arm idler bracket mounting is attached to the underside of the frame, the frame structure can crack and the idler plate can separate. This could lead to loss of steering control and a crash without warning. After inspecting the involved components, MCI initially determined that lack of proper maintenance led to the cracking and subsequent failure. Further, MCI had not received any reports of similar failures as of that time.

MCI subsequently received a report of another F3500 coach reported to have cracking in the same area. After inspecting this coach and completing its engineering analysis and review, MCI determined that the cracking had originated at the heat-affected zone of the weld at the steering arm idler bracket location, apparently as a result of insufficient welding process during manufacture. If not identified and repaired during regular maintenance and inspection, the cracking could allow movement of the idler plate, and over an extended period of time progress and result in reduced steering control or steering loss if total failure of the mounting occurred.

MCI will add reinforcement gussets to all of the coaches identified in order to reduce stress where cracking can occur and to repair the existing components in the affected units as necessary, at no cost to you.

Enclosed please find a copy of MCI Service Bulletin 279C, which describes the corrective action that should be taken as soon as possible. MCI records indicate that you are the owner or operator of the following unit(s) included in this recall:

«unit\_number»

If you have any questions about this recall campaign, you may contact the MCI Customer Service Line at 1-800-241-2947.

After contacting MCI Customer Service, if you are still unable to have the safety defect remedied without charge and within a reasonable time, you may submit a complaint:

For the U.S.:

The Administrator  
National Highway Traffic Safety Administration  
400 Seventh Street, S.W.,  
Washington, D.C. 20590

or call the toll-free Vehicle Safety Hotline at 1-888-327-4236; (TTY: 1-800-424-9153); or go to <http://www.safercar.gov>.

For Canada:

Road Safety and Motor Vehicle  
Regulation Directorate  
Transport Canada  
Tower C, Place de Ville  
330 Sparks Street  
Ottawa, Ontario  
K1A 0N5

Or, call the Transport Canada's Information Centre at 1-800-333-0371.

If you are the lessor of this vehicle, Federal law requires that you forward this notice to the lessee within ten days of your receipt of this notice.

If you had this repair performed before you received this letter, you may be eligible to receive reimbursement for the cost of obtaining a pre-notification remedy of the problem associated with this recall. For more information contact the MCI Customer Service Line at 1-800-241-2947.

If you have sold or otherwise transferred the vehicle(s) identified above, please contact the MCI Customer Service Line at 1-800-241-2947 with all of the information you have regarding the current owner/operator of the vehicle(s), so that we can ensure that the vehicles are corrected.

Motor Coach Industries apologizes for any inconvenience this may cause.

Sincerely,

Motor Coach Industries  
Warranty Department

Enclosure: MCI Service Bulletin 279



# Service Bulletin No. 279C

MODEL F3500 Series Coaches	TYPE Field Change Program	SECTION/GROUP 11-Steering	DATE Aug. 7, 2007
SUBJECT STEERING ARM IDLER BRACKET			
CONDITIONS			

**THIS BULLETIN SUPERCEDES FIELD SERVICE BULLETIN 279 & 279B IN IT'S ENTIRETY.**

Ref. NHTSA Recall No.: 07V-191

Ref. Transport Canada Recall No.: 07-146

### Customer Complaint:

Customer can experience cracking, originating at the heat-affected zone of the weld at the steering arm idler bracket location.

### Cause:

MCI determined that the cracking had originated at the heat-affected zone of the weld at the steering arm idler bracket location, apparently as a result of insufficient welding process during manufacture. If not identified and repaired during regular maintenance and inspection, the cracking could allow movement of the idler plate, and over an extended period of time progress and result in reduced steering control or steering loss if total failure of the mounting occurred.

### Corrective Action:

MCI will add reinforcement gussets to all of the coaches identified in order to reduce stress where cracking can occur and to repair the existing components in the affected units as necessary.

As a result, MCI advises that owners of F3500 model coaches between the range of, and including, unit numbers 90001 to 90163 implement the specified steps in this procedure.

### Parts

Qty.	New P/N	Description
1	26-03-0006	Kit, Front Bogie Retrofit <i>Kit Contents Are:</i>
1	03-59-2246	Angle, Re-enforcement, Front
1	03-59-2247	Angle, Re-enforcement, Rear
2	12-01-1252	Plate, Front Suspension
12	39482014-6	Bolt ( ref. p/n 19-01-2090 )
12	Z548876A35	Nut ( ref. p/n 19-03-0729 )
4	19-1-994	Capscrew
4	19-02-0383	Flatwasher
4	19-03-0582	Nut, Lock



## NOTE

**Welding may only be done by an experienced and qualified person. All welding must conform to AWS D1.1 Structural Welding Code - Steel. All applicable instructions and prohibitions must be followed.**

**Follow the correct welding disconnect procedure on Pages 3 and 4.**

The following procedure can be done using either welding method listed below:

1. SHIELDED METAL ARC WELDING ( SMAW )
  - a. 1 / 8 rod - E7018 stick welding rod
2. GAS METAL ARC WELDING ( GMAW )
  - a. 0.035 diameter ER70S-6 wire ( shielding gas - 90% - 92% Argon, 10% - 8% CO2 )  
( or alternate - shielding gas - 80% - 85% Argon, 20% - 15% CO2 )



## NOTE

The coach will require an alignment after completion of the procedure steps.

### Service Procedure:

#### General notes

Read this entire procedure before beginning work.

Use Safe Shop Practices At All Times.

1. Drive the coach over a pit, or use a lift to access the steering arm idler brackets.



## NOTE

If the steps in this procedure are performed over a pit, apply the park brake and chock both sides of the tires. Open the engine door and position the toggle switch on the engine remote to the Neutral position.

If the steps in this procedure are performed with the coach on a lift, raise coach to desired height. Position jackstands at the front and rear frame support points, according to Figure 1, to ensure that the coach is securely supported before attempting work underneath the coach.

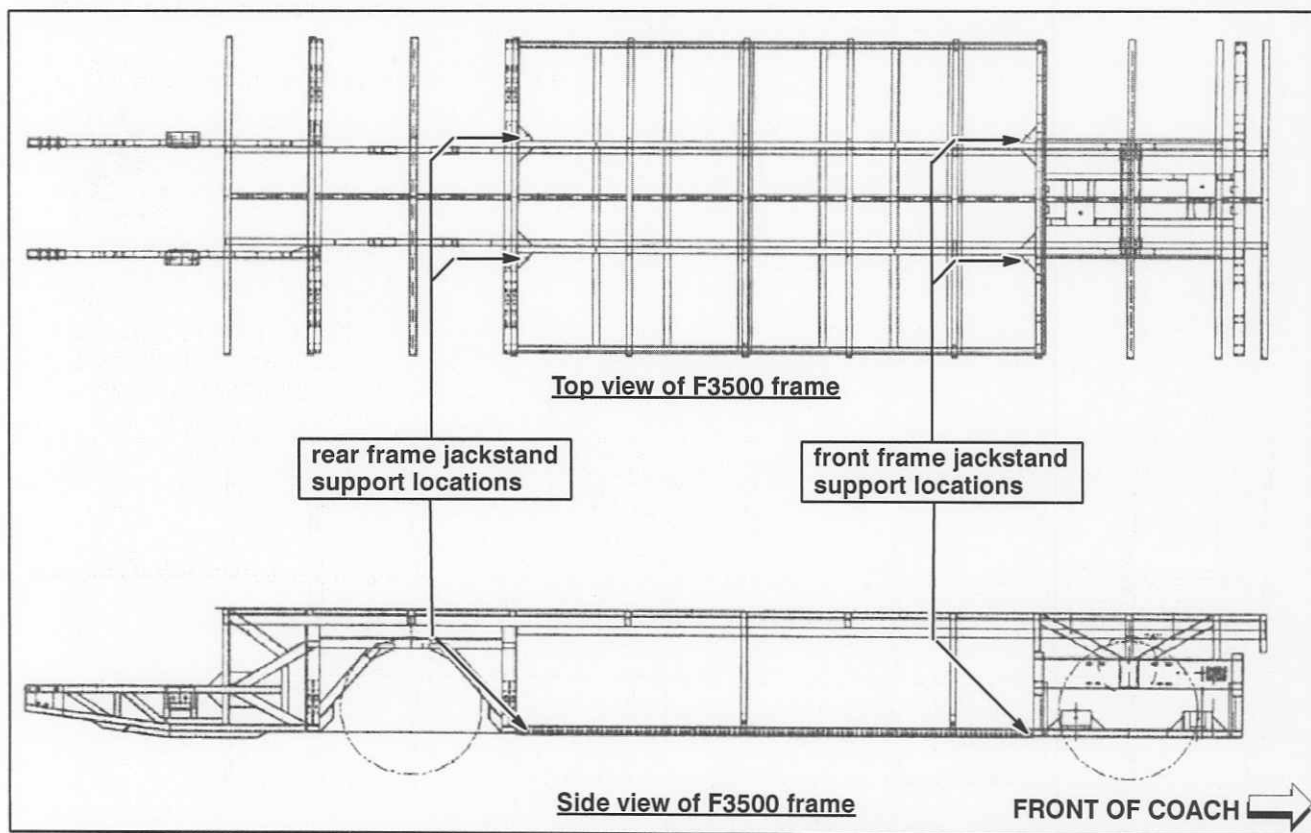

Figure 1. Underframe Jackstand Support Points.



## WELDING CAUTION

---

*The following information must be read before beginning any welding. The prohibitions and requirements must be followed to prevent personal injury and damage to electrical components. Also follow any welding instructions and cautions associated with the specific component being repaired.*

*Welding may only be done by an experienced and qualified person. All welding must conform to AWS D1.1 Structural Welding Code - Steel. All applicable instructions and prohibitions must be followed.*

*Position ground contacts and barriers as close as possible to the weld area to protect components (wiring, brake lines, hydraulic lines, etc.) from heat, contact by weld splatter and arcing.*

### PRE-WELDING DISCONNECTION

1. Switch the main battery disconnect OFF.
2. In the **battery compartment**, in the order given:
  - a. Disconnect the ground.
  - b. Disconnect the 12-volt cable at the battery.
  - c. Disconnect the 24-volt cable at the battery.
3. In the **junction box**, in the order given:
  - a. Disconnect transmission ECU ( 3 connectors )
  - b. Disconnect anti-lock brake ECU ( 4 connectors )
  - c. Disconnect HVAC control module ( 2 connectors )
4. In the **engine compartment**, in the order given:
  - a. Disconnect engine ECM ( 5 connectors )
  - b. Disconnect transmission main plug ( 1 connector )
5. In the **drivers console**:
  - a. Disconnect translator module ( plug P-15 )
6. In the **instrument panel**:
  - a. Disconnect black connector ( plug P-19 )
7. In the **steering column**:
  - a. Disconnect 3 connectors ( plug P-AA, P-BB & P-183 )
8. In the **wiper control module**:
  - a. Disconnect 2 connectors ( plug P-10 & P-11 )
9. In the **cruise control module**:
  - a. Disconnect 3 connectors ( plug J-2, J-3 & P-31 )



### NOTE

*This coach is equipped with an electronic battery equalizer. To avoid reverse polarity damage when disconnecting battery terminals, always: REMOVE EQUALIZER GROUND FIRST, AND REPLACE LAST.*

## POST-WELDING CONNECTION

1. When welding is complete, re-connect all items in the **exact reverse order** from disconnection. Re-connection order is critical to safety.



---

## WARNING

---

*To prevent personal injury, exercise extreme caution at power-up.*

2. Verify that all connections are complete and secure.
3. Warn all personnel in the area that the power is going to be switched ON.
4. Ensure that all personnel are clear of the immediate area.
5. Switch the main battery disconnect ON.

1. Turn the main disconnect switch to the OFF position.
2. Locate the steering arm idler brackets on the curbside and roadside of the front axle ( refer to Figure 2 ).
3. Remove steering arm idler and tie rods, if necessary. Discard existing steering arm idler mounting hardware.
4. Visually inspect the steering arm idler bearings for damage. Replace if necessary.



## NOTE

**Ensure steering arm idler bearings are properly lubricated.**

5. Using an industrial heat gun and steel brush, clean the four weld areas shown in Detail A and the two weld areas shown in Figure 3 / Detail B.



## NOTE

**Ensure that all the dirt and loose rust has been removed.**

6. Inspect the four weld areas shown in Figure 2 / Detail A and the two weld areas shown in Figure 3 / Detail B.
7. If a crack is present, at the location shown in Figures 2 and 3:
  - a. drill a 1/8 inch hole at the extreme end of the crack,
  - b. bevel both sides of the crack to create a V groove,
  - c. run a continuous weld, ensuring full penetration,
  - d. grind the weld flush with the face of the plate.
8. Locate the existing suspension plate shown in Figure 4 / Detail A. Remove and discard the existing suspension plate and mounting hardware. Install the new suspension plate ( p/n 12-01-1252 ) using the mounting hardware provided ( p/n 19-1-994, 19-02-0383 and 19-03-0582 ). Hand-tighten and snug the nut's. Repeat to the opposite side. Weld the suspension plates, using the weld size and location in Figure 4 / Detail A.
9. Tack weld the angles ( p/n 03-59-2246 and 03-59-2247 ) into position, according to Figures 4 and 5.
10. Weld the angles, using the weld sizes and locations in Figures 4, 5 and 6.



## CAUTION

**Allow weld area to cool down at room temperature.**

11. Apply rust paint to the installation area.
12. Torque the suspension plate nut's to 50–75 ft.-lbs.
13. Re-install the steering arm idler, removed in Step 3. , using bolt ( p/n 39482014-6 ) and nut ( p/n Z548876A35 ) ( Figures 4, 5 and 6 ). Torque nut to 105–135 ft.-lbs.



## NOTE

**The coach will require an alignment after completion of the procedure steps.**

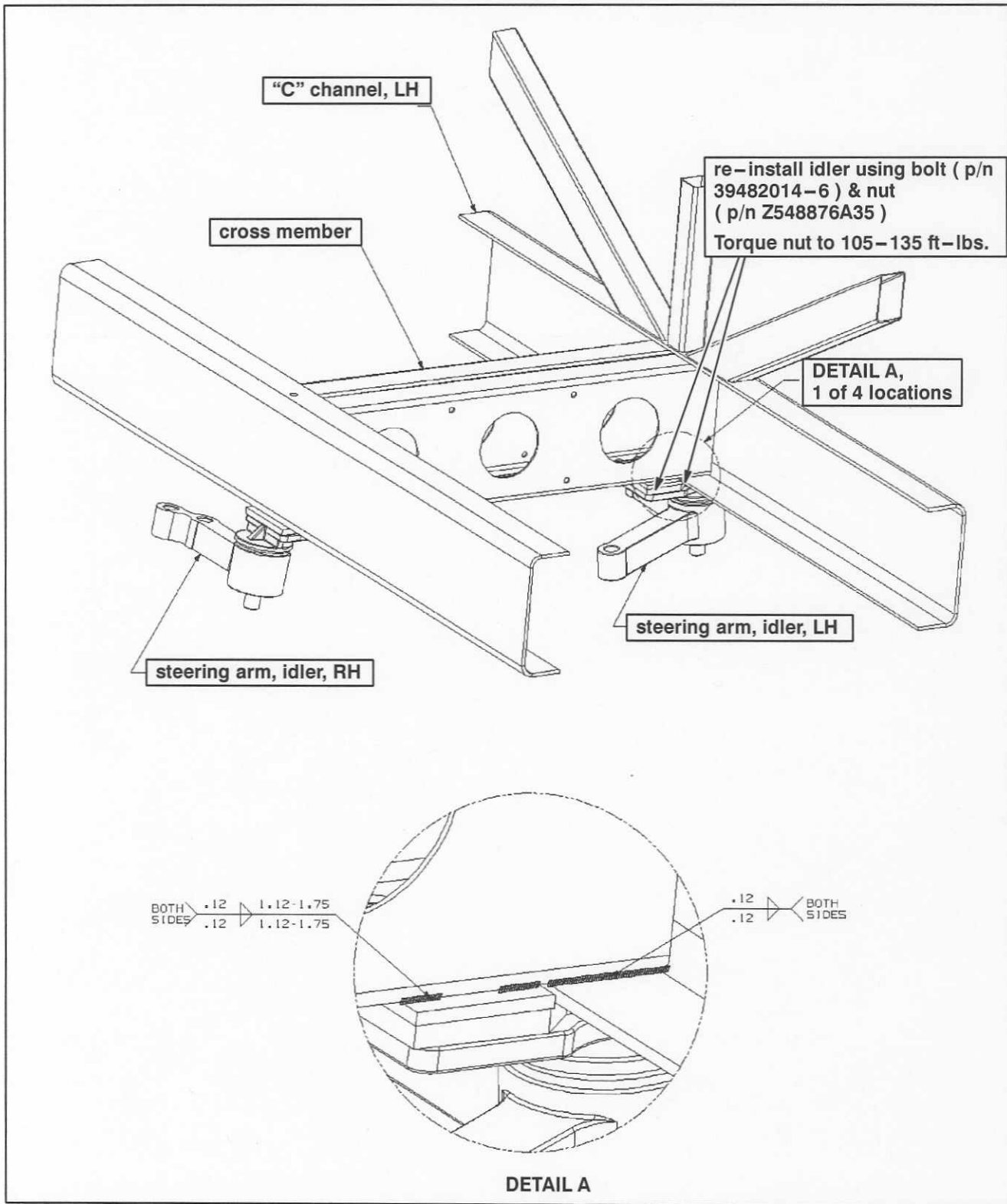

Figure 2. Top view of front bogie. Inspection required of four locations.

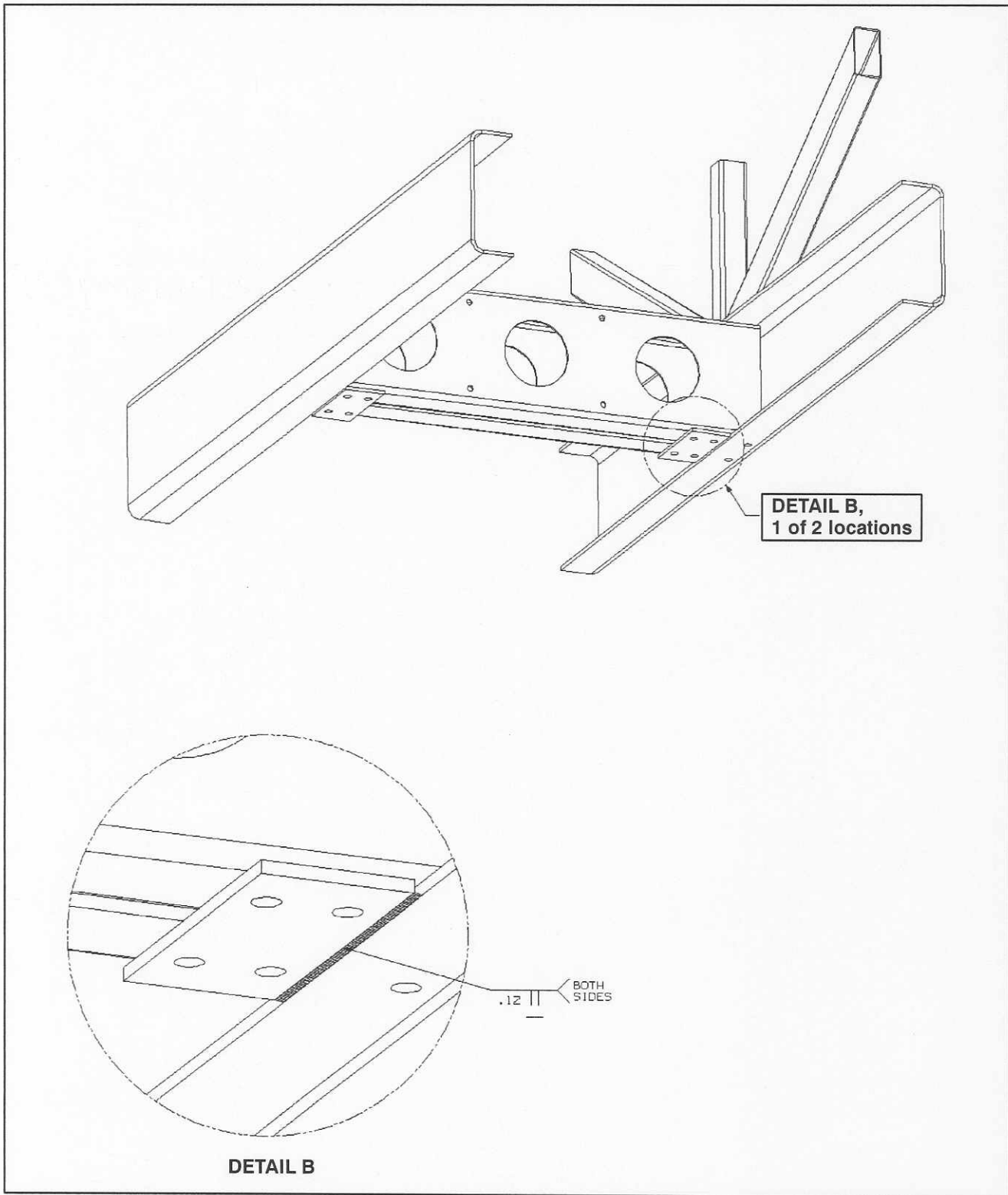
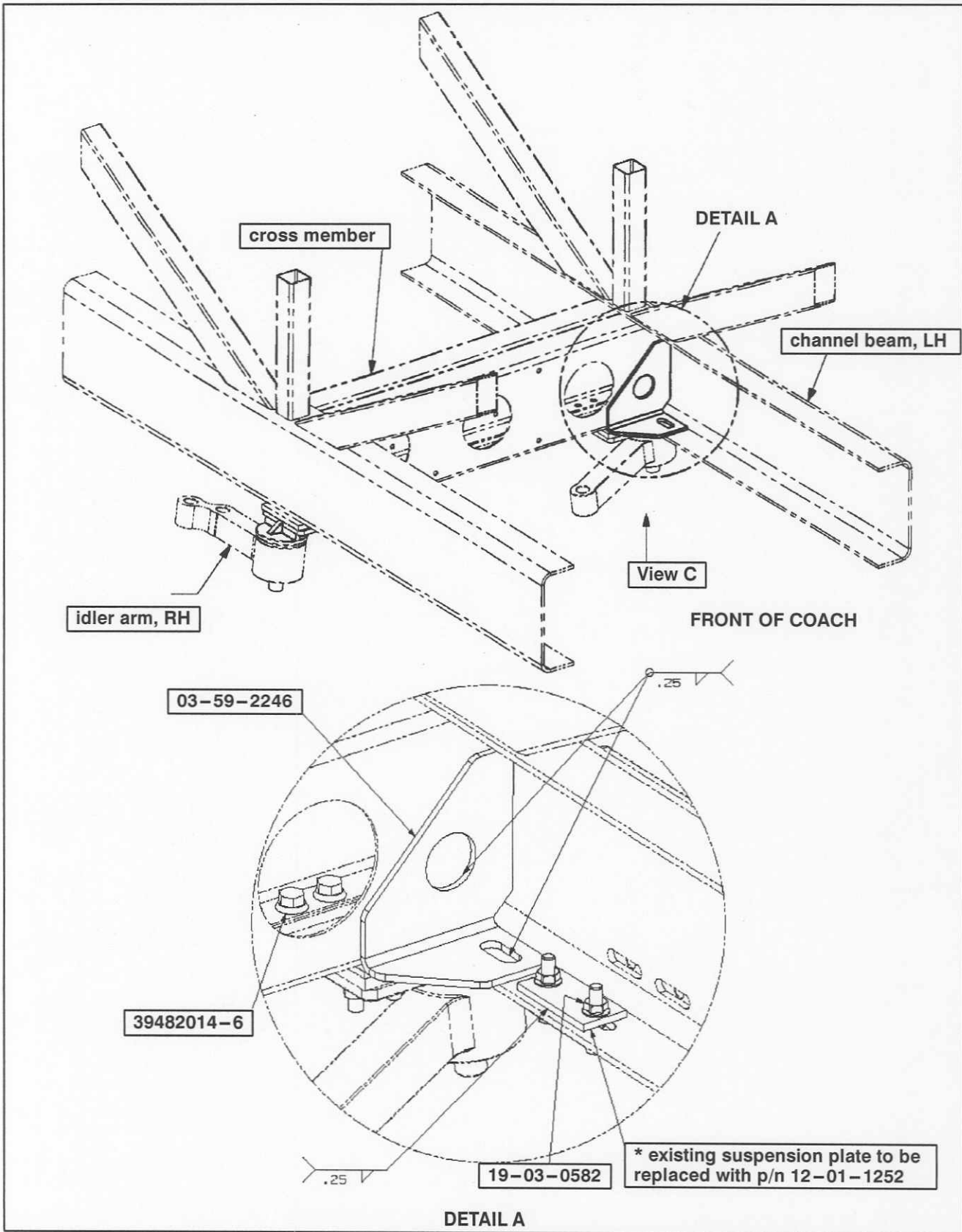

Figure 3. Bottom view of front bogie. Inspection required of two locations.



DETAIL A

Figure 4.

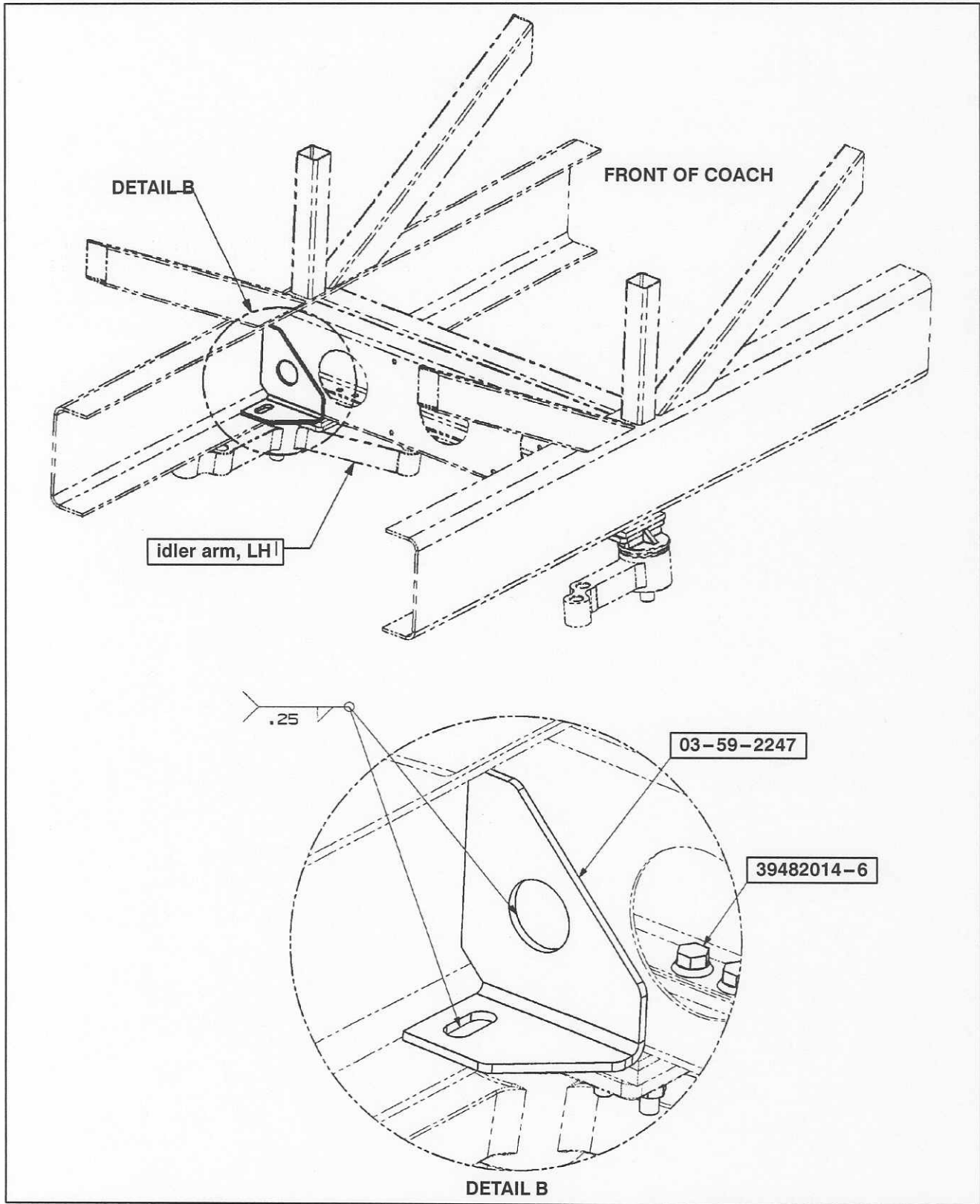

Figure 5.

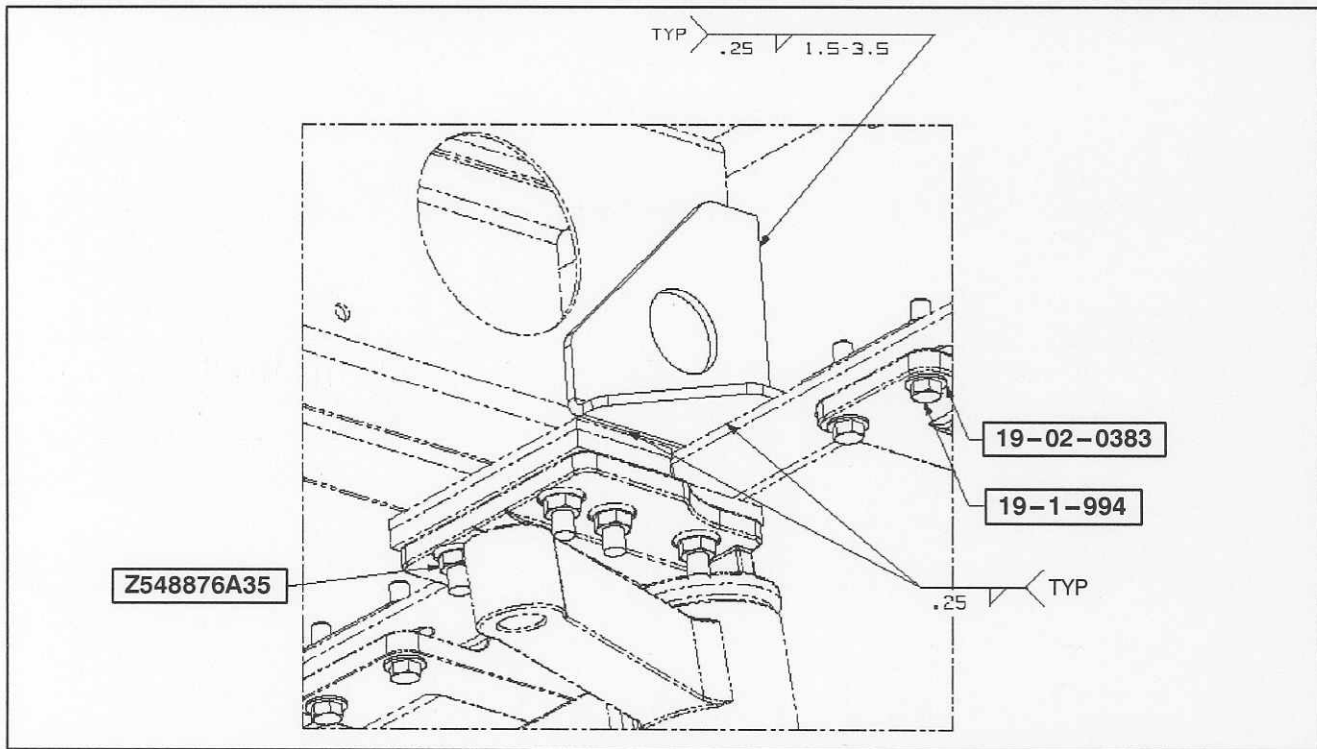

Figure 6. View C.

Procedure complete.

Mail or fax the completed warranty claim form to MCI's warranty department, or photocopy and mail it to:

MCI Fleet Support  
Attn: Warranty Department  
7001 Universal Coach Drive  
Louisville, KY 40258  
Fax Number 1-800-360-8886

to receive credit for the hours used to complete this task. Contact the MCI Fleet Support Technical Center at 1-800-241-2947 for any further information.

***Field Change Program Conditions:***

The parts required for this change will be supplied without charge.

A labor allowance of 11.0 hours will be granted, for the procedure of installing the specified part(s) in this bulletin and an alignment on F3500 model coaches.

**Only 1 claim can be filed against the coach VIN, SB 279, SB 279B or SB 279C.**

This labor allowance will be credited to your MCI Fleet Support Parts Account on receipt of a "Warranty Claim Form" as detailed in your Owner Warranty manual.

Motor Coach apologizes for any inconvenience resulting from this campaign, but urges you to implement this change as soon as possible.

Sincerely,

*Motor Coach Industries*  
U.S. and Canadian Service Departments.