



07E-009

Re: NHTSA Campaign #07E-009
Components: SUSPENSION
Initiating Party: LKI Enterprises, Inc. dba Superlift Suspension™

Dear Ms. Schuler:

Superlift Suspension intends to mail the attached customer notification beginning next week. Note since originally submitted we have amended the customer notification form to include the “doesn’t apply to OEM Dodge Trucks” note NHTSA provided in its public recall information. Should you or staff have any questions or comments please contact me. We anticipate making our first 573 report soon.

Regards,

Darryl Boutwell



SAFETY RECALL NOTICE

RE: Recall (LKI# 07-01): SUPERLIFT® Customer Notification and Instructions for replacement / reimbursement

Affected Part: Part #4007 series pitman arm for 2003 and newer Dodge 2500 / 3500 sold individually or included in Superlift® Suspension Kits packaged between 9/21/05 and 1/16/07 (see complete list of kits and box numbers below)

Effective Date: Immediate

Dear Superlift® Customer:

This notice is sent to you in accordance with the requirements of the National Traffic and Motor Vehicle Safety Act. LKI Enterprises, Inc., dba Superlift Suspension Systems ("Superlift®") has decided that a defect which relates to motor vehicle safety exists in certain part # 4007 series pitman arms either sold individually or included in the suspension kit part numbers (and related kit boxes) identified below between approximately 9/21/05 and 1/16/07. This notice is intended to advise you of a recall of these pitman arms and provide instructions for replacement / reimbursement of the affected parts at no to you.

REASON FOR THIS RECALL: Superlift® has determined that affected pitman arms may have inconsistent heat treating and broaching of the arm's splines. This may result in movement between the pitman arm and steering sector output shaft, premature wear of the splines and cracking or failure of the pitman arm.

WARNING !: Unusual play in steering may indicate risk of pitman arm failure and crash. To avoid loss of vehicle control, risk of injury or damage, customers should not use vehicle prior to replacement of pitman arm when inspection indicates movement of pitman arm on steering output shaft.

WHAT YOU SHOULD DO: Affected pitman arms should be replaced regardless of whether inspection indicates movement between the arm and steering sector output shaft. Replacement pitman arms should be available from your Superlift® dealer by the time you receive this notice. Alternatively, you may contact Superlift® customer service direct at (800-551-4955) or write Superlift® Customer service (re: recall #07-01) 300 Huey Lenard Loop Rd., West Monroe, LA 71292 for a free replacement pitman arm. A pre-paid Fed-Ex shipping label available from Superlift® will be provided to return the effected arm. If you prefer, your Superlift® jobber / installer can replace affected pitman arms and Superlift® will reimburse for reasonable labor charges (up to 1.0 hour) upon return of pitman arm and work invoice, using a pre-paid Fed-Ex shipping label available from Superlift®. A copy of the pitman arm removal / replacement instructions included with your Superlift® kit are attached.

Customers who have already replaced affected pitman arms may be eligible for reimbursement of replacement costs and labor. Call or write Superlift® at the above toll-free number / address for details.

If you no longer own this vehicle, please forward this notice to the current owner and contact Superlift® with the new owner's address. If you are the Lessor of any vehicle affected by this recall you are required to provide a copy of this notification to the most recent Lessee known to you via first class mail within ten (10) days.

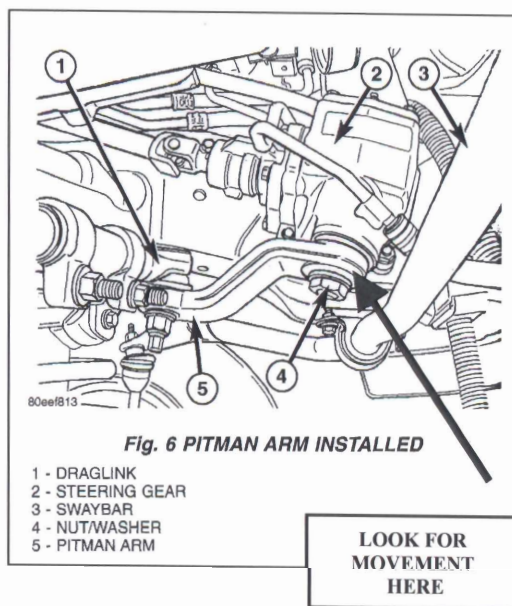



IDENTIFYING AFFECTED PITMAN ARMS: The affected pitman arms were sold as individual parts *and* included in the following kit part numbers for Superlift® 4" and 6" suspension kits for Dodge 2500 / 3500, model year 2003 and up, packaged by Superlift® between approximately 9/21/05 and 1/16/07. This recall only pertains to replacement pitman arms furnished in the Superlift® kits identified herein and has no relation to any original equipment installed on Dodge Ram 4x4 light trucks manufactured by DaimlerChrysler. Affected Pitman arms are identified as follows:

PITMAN ARMS SOLD INDIVIDUALLY

Part # 4007
Part # 04-4640

"K" KIT PART NUMBERS

K834, K834B, K834R
K835, K835B, K835R
K832, K832B, K832R
K833, K833B, K833R
K756, K756B, K756R
K757, K757B, K757R
K760, K760B, K760R
K761, K761B, K761R
K821, K821B, K821R
K822, K822B, K822R
K823, K823B, K823R
K824, K824B, K824R

KIT BOX NUMBERS

4640, 4640B, 4640R
4645, 4645B, 4645R
4650, 4650B, 4650R
4655, 4655B, 4655R
4660, 4660B, 4660R
4665, 4665B, 4665R
4670, 4670B, 4670R
4675, 4675B, 4675R



SAMPLE KIT BOX LABEL: Referencing the packaged date may help identifying suspect parts. Affected pitman arms were packaged between approximately 9/21/05 and 1/16/07. Superlift® packaged date begins with the 5th digit of the label. For example, this pitman arm was shipped 12/14/06. Additionally, pitman arms are identified by a paint stripe. Affected arms have a purple stripe; new edition arms have a gold stripe.

INSTRUCTIONS FOR REMOVAL AND REPLACEMENT OF PITMAN ARM

See attached instruction form.

FURTHER ASSISTANCE: If you have questions regarding this recall, or are unable to obtain replacement pitman arms without charge, contact Superlift® customer service toll-free at (800-551-4955). If after a reasonable period of time, you are unable to obtain satisfactory service regarding this recall or a replacement pitman arm without charge, you may also submit a complaint to the Administrator, National Highway Traffic Safety Administration, 400 Seventh St., S.W., Washington DC 20509 or call the toll-free Vehicle Safety Hot Line at 888-327-4236 (tty: 800-424-9153); or go to <http://www.safercar.gov>. Washington DC residents may call 202-366-0123.

We regret any inconvenience this recall may cause but hope you share our concerns for safe use and enjoyment of Superlift® products.

Thanks,

Darryl Boutwell, Production Manager