

July 2008  
FL509A-C  
NHTSA #07V-343  
REVISED NOTICE

## **Subject: ZF Lenksysteme 8018 Steering Gears**

**Models Affected: Specific Freightliner Custom Chassis VCL, XB, and XC motorhome chassis manufactured between June 13, 2002, and June 13, 2007, with certain independent front suspension assemblies with ZF Lenksysteme 8018 steering gears.**

### **General Information**

Freightliner LLC, on behalf of its wholly owned subsidiary, Freightliner Custom Chassis Corporation, has decided that a defect that relates to motor vehicle safety exists on the vehicles mentioned above.

There are approximately 6,000 vehicles involved in this campaign.

Certain ZF Lenksysteme model 8018 steering gears may have been assembled with the incorrect recirculating ball spacer; this may allow the recirculating balls to escape their circuit. If this happens, the operator may notice that higher steering wheel inputs are required or the need for more steering wheel adjustments while driving in a straight line in combination with metallic cracking noises prior to a loss of steering. A loss of steering may result in a possible vehicle crash.

Steering gears will be inspected for certain manufacturing date codes and mileage at the time of inspection. Gears assembled during the affected periods and in a certain mileage range will be replaced.

NOTE: FL509 is being released in phases – FL509A (1,500 vehicles) was released first, FL509B (2,000 vehicles) is now being released, and FL509C (the remaining vehicles) will follow at a later date. Please perform the recall when ServicePro shows it is open for the specific vehicle.

REVISION: FL509B has now been activated. For FL509B, an additional inspection step has been added. The FL509A inspection is unchanged.

### **Additional Repairs**

Dealers must complete all outstanding recall and field service campaigns prior to the sale or delivery of a vehicle. A Dealer will be liable for any progressive damage that results from its failure to complete campaigns before sale or delivery of a vehicle.

Owners may be liable for any progressive damage that results from its failure to complete campaigns within a reasonable time after receiving notification.

### **Work Instructions**

Please refer to the attached work instructions. Prior to performing the campaign, check the vehicle for a completion sticker (Form WAR260).

### **Replacement Parts**

Replacement kits are now available and can be obtained by ordering the kit number(s) listed below from your facing Parts Distribution Center.

If our records show your dealership has ordered any vehicles involved in campaign number FL509A-C, a list of the customers and vehicle identification numbers will be available on AccessFreightliner.com. Please refer to this list when ordering parts for this recall.

# Recall Campaign

Daimler Trucks  
North America LLC

July 2008  
FL509A-C  
NHTSA #07V-343  
REVISED NOTICE

Table 1 - Replacement Parts for FL509

Campaign Number	Kit Number	Part Description	Part Number	Qty. per Kit	Suggested Wholesale*
FL509A-C	25-FL509-000	Steering Gear and Pitman Arm Assembly	8018 974 103	1 ea	\$841.02 U.S. \$841.02 CAN
		Completion Sticker	WAR260	1 ea	

\* Please charge all Direct Warranty Customers the above-listed price for the kit, as they are authorized to perform their own Recalls.

Table 1

## Removed Parts

Please follow Warranty Failed Parts Tracking shipping instructions for the disposition of all removed parts.

## Labor Allowance

Table 2 - Labor Allowance

Campaign Number	Procedure	Time Allowed (hours)	SRT Code	Damage Code
FL509A-C	Inspect steering gear date code	0.2	996-0738A	000-Inspected
	Inspect steering gear date code and replace steering gear/pitman arm assembly	3.5	996-0738B	000-Modifiedx

Table 2

**IMPORTANT:** When the recall has been completed, locate the base completion label in the appropriate location on the vehicle, and attach the red completion sticker provided in the recall kit (Form WAR260). If the vehicle does not have a base completion label, clean a spot on the appropriate location of the vehicle and first attach the base completion label (Form WAR259). If a recall kit is not required or there is no completion sticker in the kit, write the recall number on a blank sticker and attach it to the base completion label.

## Claims for Credit

You will be reimbursed for your parts, labor, and handling by submitting your claim through the Warranty system within 30 days of completing this campaign. Please reference the following information in QuickClaim®:

- Claim type is **Recall**.
- In the FTL Authorization field, enter the campaign number and appropriate condition code (e.g. **FL509A**, **FL509B**, etc.).
- In the Primary Failed Part Number field, enter **25-FL509-000**.
- In the Parts field, enter the appropriate kit number(s) as shown in the Replacement Parts Table.
- In the Labor field, first enter the appropriate SRT from the Labor Allowance Table. For administrative time, enter SRT 939-0010A for 0.4 hours for RVs.
- For **FL509B** and **FL509C**, note the vehicle's mileage in the claim comments.
- **FL509** is being released in phases – **FL509A** (1,500 vehicles) was released first. **FL509B** (2,000 vehicles) has not been activated, and **FL509C** (the remaining vehicles) will follow at a later date. Please perform the recall when ServicePro shows it is open for the specific vehicle.

July 2008  
FL509A-C  
NHTSA #07V-343  
REVISED NOTICE

- **Reimbursement for Prior Repairs.** When a customer asks about reimbursement, please do the following.
  - Accept the documentation of the previous repair.
  - Make a brief check of the customer's paperwork to see if the repair may be eligible for reimbursement. (See the "Copy of Owner Letter" section of this bulletin for reimbursement guidelines for this recall.)
  - Contact the Warranty Campaigns Department for a decision and authorization number.
  - Include the approved amount on your claim in sublet/outside purchases.
  - In the claim story, first note the authorization number and that the claim includes a reimbursement request.
  - Retain the documentation and provide it to Warranty Campaigns or Claims Processing if requested.
  - When your claim is paid, reimburse the customer the appropriate amount.

**IMPORTANT:** ServicePro® must be viewed prior to performing the recall to ensure the vehicle is involved and the campaign has not been previously completed. Also, check for a completion sticker prior to beginning work.

Contact the Warranty Campaigns Department at (800) 547-0712, from 7:00 a.m. to 4:00 p.m. Pacific Time, Monday through Friday, Web inquiry at [AccessFreightliner.com / Support / Submit an Inquiry](http://AccessFreightliner.com/Support/SubmitanInquiry), or the Customer Assistance Center at (800) 385-4357, after normal business hours, if you have any questions or need additional information.

To return excess kit inventory related to this campaign, U.S. dealers must submit a Parts Authorization Return (PAR) to the Memphis PDC. Canadian dealers must submit a PAR to their facing PDC. All kits must be in resalable condition. PAR requests must include the original purchase invoice number.

The letter notifying vehicle owners is included for your reference.

Please note that the National Traffic and Motor Vehicle Safety Act, as amended (Title 49, United States Code, Chapter 301), requires the owner's vehicle(s) be corrected within a reasonable time after parts are available to you. The Act states that failure to repair a vehicle within 60 days after tender for repair shall be prima facie evidence of an unreasonable time. However, circumstances of a particular situation may reduce the 60 day period. Failure to repair a vehicle within a reasonable time can result in either the obligation to (a) replace the vehicle with an identical or reasonably equivalent vehicle, without charge, or (b) refund the purchase price in full, less a reasonable allowance for depreciation. The Act further prohibits dealers from selling a vehicle unless all outstanding recalls are performed. Also, any lessor is required to send a copy of the recall notification to the lessee within 10 days.

# Recall Campaign

Daimler Trucks  
North America LLC

July 2008  
FL509A-C  
NHTSA #07V-343  
REVISED NOTICE

## Work Instructions

### Subject: ZF Lenksysteme 8018 Steering Gears

**Models Affected:** Specific Freightliner Custom Chassis VCL, XB, and XC motorhome chassis manufactured between June 13, 2002, and June 13, 2007, with certain independent front suspension assemblies with ZF Lenksysteme 8018 steering gears.

NOTE: FL509 is being released in phases – FL509A (1,500 vehicles) was released first, FL509B (2,000 vehicles) is now being released, and FL509C (the remaining vehicles) will follow at a later date. Please perform the recall when ServicePro shows it is open for the specific vehicle.

REVISION: FL509B has now been activated. For FL509B, an additional inspection step has been added. The FL509A inspection is unchanged.

### Inspection Procedures

#### Manufacturing Date Code Inspection

1. Check the base label (Form WAR259) for a completion sticker for FL509 (Form WAR260) indicating this work has been done. The base label is usually located on the front wall under the dash in motor homes. If a sticker for FL509 is present, nothing further needs to be done. If a sticker is not present, go to the next step.
2. Shut down the engine, set the parking brake, and chock the tires.
3. Check the date code on the data plate of the steering gear. See Fig. 1.
  - 3.1 If the date code is 250407 or more, nothing further needs to be done. Go to Step 4.
  - 3.2 If the date code is less than 250407:  
If the vehicle is in FL509A, go to "Steering Gear Replacement."  
If the vehicle is in FL509B or FL509C, go to "Mileage Inspection."

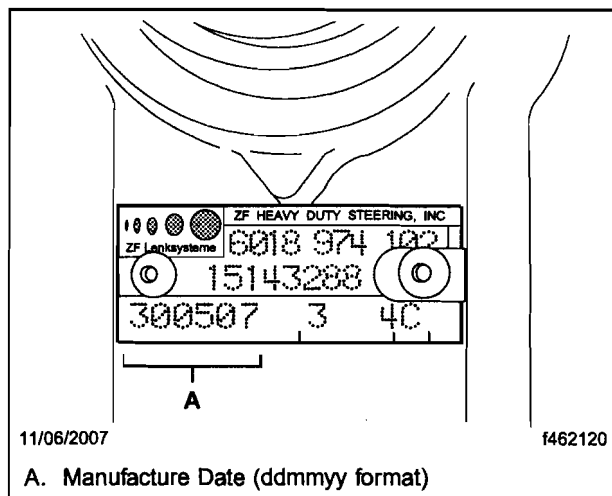

Fig. 1, Data Plate Identification

4. Clean a spot on the base label, write the Recall number, FL509, on a blank completion sticker, and attach it to the base label.
5. Remove the chocks from tires.

## Mileage Inspection

NOTE: The mileage inspection applies to vehicles in FL509B and FL509C. The mileage inspection does not apply to vehicles in FL509A.

1. Check the odometer for the vehicle's current mileage. Include the mileage in the recall claim comments.
2. If the current mileage is 15,000 miles or less, go to "Steering Gear Replacement."

If the current mileage is more than 15,000 miles, clean a spot on the base label, write the Recall number, FL509, on a blank completion sticker, and attach it to the base label.

## Steering Gear Replacement

NOTE: Please save and reuse the kit shipping container to return the removed steering gear assembly.

1. Raise and support the vehicle so there is 12 inches (30 cm) clearance from the ground. Position jack stands under the frame rails to support the vehicle.
2. Remove the tie-rods.
  - 2.1 Remove the cotter pins and loosen the tie-rod end retaining nuts on the left and right sides. Leave the nut loosely attached.

IMPORTANT: Do not use a pry-bar or pickle fork to remove the tie-rod end, this will damage the seal and require replacement.
  - 2.2 Use a two-arm gear puller to press the tie-rod end ball stud out of the steering arm taper. Disconnect and set the tie rod end aside.
3. Bleed the steering gear according to shop practice. Mark and disconnect the pressure and return hoses from the steering gear.
4. Disconnect the intermediate shaft.
  - 4.1 Remove the pinch bolt from the U-joint of the intermediate shaft.
  - 4.2 Spread the joint slightly by using a screwdriver, tap, or punch in the slot to increase the gap.
  - 4.3 Slide the U-joint forward and out of the way.

NOTE: The pitman arm must be removed assembled to the steering gear output shaft. It is optional to leave the tie-rods attached to the pitman arm and remove the entire assembly at one time. You may also remove the inner tie-rod end from the pitman arm at this time via the two-arm gear puller used for the outer tie-rod ends.

5. Remove the steering gear.
  - 5.1 Using a 1-3/16 impact socket, loosen the four mounting bolts. See **Fig. 2**.

IMPORTANT: Use two assistants while performing the following procedures.
  - 5.2 Remove three nuts, leaving the centermost assembled in order to prevent the steering gear from falling.
  - 5.3 Position 1 x 4 boards (as needed) across the lower control arms, and use a transmission jack to support and receive the gear when it's disconnected. Remove the last nut, lower the gear, and remove to one side.

# Recall Campaign

Daimler Trucks  
North America LLC

July 2008  
FL509A-C  
NHTSA #07V-343  
REVISED NOTICE

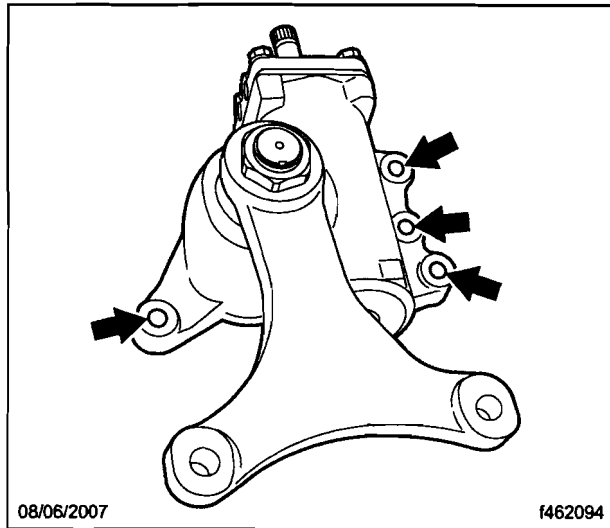

**Fig. 2, Steering Gear Mounting Bolts**

6. Install the new steering gear.

**IMPORTANT:** Use two assistants while performing the following procedure.

- 6.1 Position the new steering gear and pitman arm below its assembled position.
- 6.2 Using a transmission jack, lift the gear into place, piloting on the mounting bolts, then quickly thread at least one nut into place to prevent the gear from falling.
- 6.3 Install all remaining nuts, then tighten all four nuts 378 to 462 lbf-ft (18 to 22 N·m).
- 6.4 Connect the pressure and return hoses to the steering gear.

7. Connect the intermediate shaft.

- 7.1 Slide the intermediate shaft U-joint onto the steering gear input shaft.
- 7.2 Install a new pinch bolt in the U-joint, then install a new locknut on the pinch bolt and tighten the locknut 55 to 65 lbf-ft (75 to 88 N·m)
- 7.3 Apply white Torque Seal F-900 to the exposed pinch-bolt thread and to the locknut.

8. Install the tie-rod.

- 8.1 Insert the tie-rod end ball into the steer arm taper. Connect the tie-rod end.

**IMPORTANT:** Before tightening tie-rod end fasteners, coat the tie-rod end ball with 15/40 oil.

- 8.2 Tighten the outer tie-rod retaining nuts on the left and right sides. Tighten to 184 lbf-ft (250 N·m).
- 8.3 Install the cotter pins

**NOTE:** Poppets are preset, there is no poppet valve adjustment needed.

9. Clean a spot on the base label and attach a completion sticker for Recall FL509.
10. Remove the chocks from the tires.