

SERVICE PROCEDURE

**G-07503
March 2007**

**SUBJECT: SAFETY RECALL (U.S., EXPORT)
SIDE EMERGENCY DOOR HOLDBACK on certain CE,
RE and FE School and Commercial Buses built
3/12/2004 thru 11/29/2006**

DEFECT DESCRIPTION

The side emergency door holdback mechanism may not be installed in the proper location. This may cause the mechanism to hold the door in the closed position.

If the door is held in the closed position, it may not perform its intended emergency function, possibly resulting in property damage, personal injury or death.

MODELS INVOLVED

This Safety Recall involves certain CE, RE, and FE school and commercial buses built 3/12/2004 thru 11/29/2006 with side emergency doors, feature codes:

0047DCN	0049DCP	0047DCR	0047DCT
0047DCX	0047DCL	0047DCJ	0047ALT

SERVICE PROCEDURE



WARNING:

TO AVOID SERIOUS EYE INJURY, ALWAYS WEAR SAFE EYE PROTECTION WHEN YOU PERFORM VEHICLE MAINTENANCE OR SERVICE.



WARNING:

TO AVOID PROPERTY DAMAGE, PERSONAL INJURY, OR DEATH WHEN SERVICING THE VEHICLE, PARK ON A FLAT LEVEL SURFACE, SET THE PARKING BRAKE, SHUT THE ENGINE OFF AND CHOCK THE WHEELS.

Please perform the following inspection to determine if further action is necessary:

1. Remove the **side** emergency door head bumper.

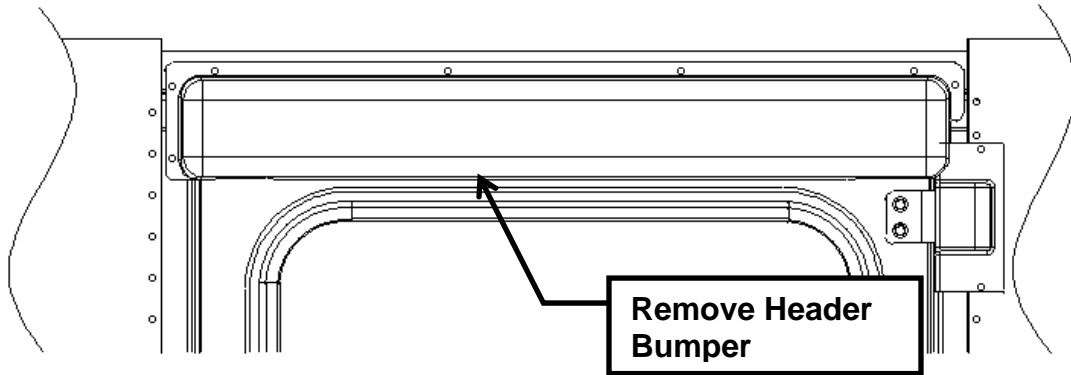

Figure 1

2. Measure dimension **A** on the hold back mechanism bolt pattern indicated below:

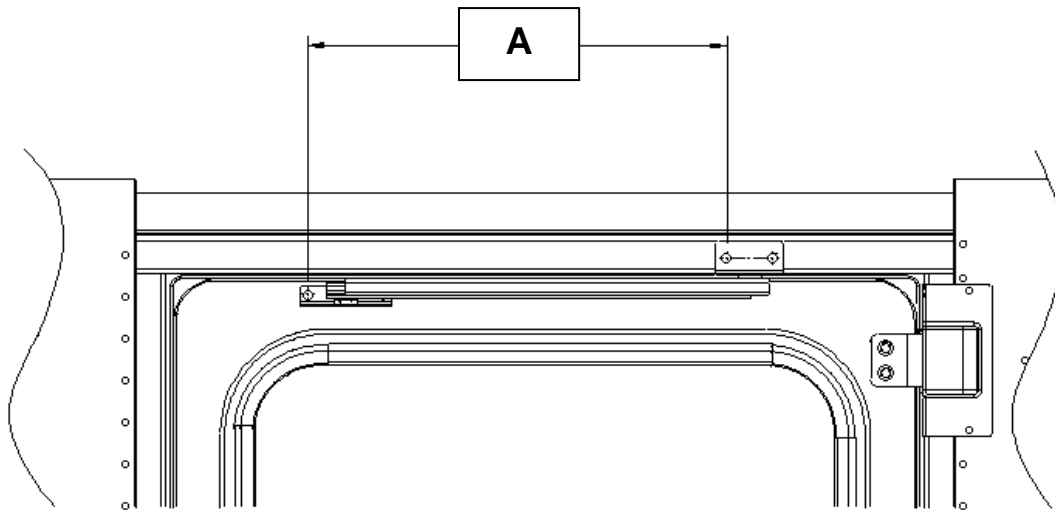

Figure 2

- a. If dimension **A** is **13"** (330mm) or **greater**, then no further action is necessary, re-install header bumper.
- b. If dimension **A** is **less** than **13"** (330mm), continue on to step 3.

3. If dimension **A** is less than **13" (330mm)**:
 - a. Remove bolts from holdback mechanism.
 - b. Measure location for new hole using Nominal dimension from Table 1.
Measure from door frame surface, not hinge surface.
 - c. Drill hole with **#5** drill bit.
 - d. Use holdback bracket as a template to mark and drill second holes.
 - e. Reinstall holdback mechanism using existing hardware.

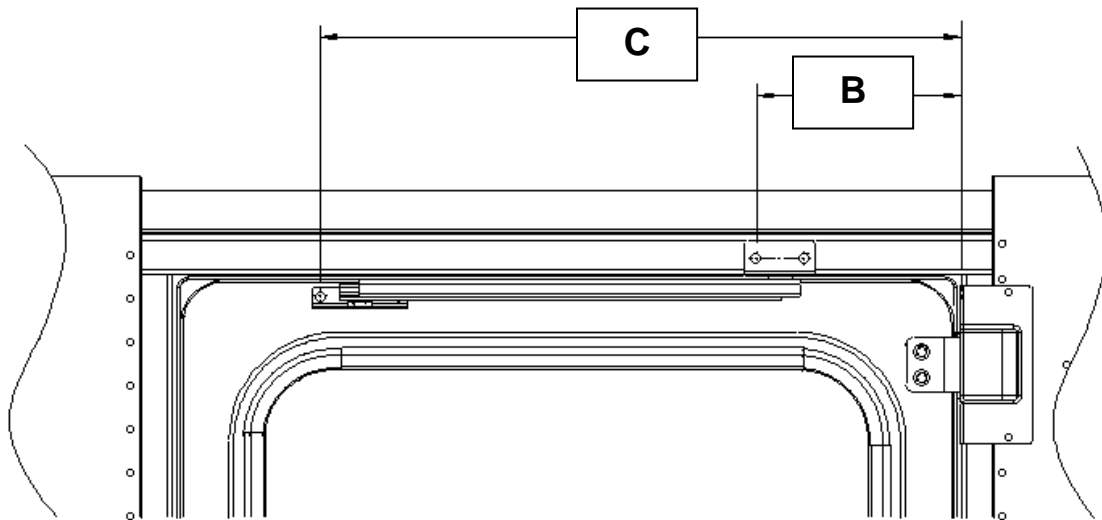

Figure 3

<u>Dimension</u>	<u>Nominal</u>
B	6.5" (165mm)
C	20.375" (517mm)

Table 1

4. Check for normal, smooth operation of the door hold back mechanism. Check to ensure door opens to at least 90° (perpendicular to bus body).
5. Re-install header bumper.

END OF SERVICE PROCEDURE

PARTS INFORMATION

There are no parts necessary to complete this Recall Service Procedure.

LABOR INFORMATION

<u>Operation No.</u>	<u>Description</u>	<u>Time</u>
A40-07503-1	<i>Inspection of Holdback Location ONLY</i>	0.3 hr
A40-07503-2	<i>Inspection AND Relocation of Holdback</i>	0.4 hr

CAMPAIGN IDENTIFICATION LABEL

*Each vehicle corrected in accordance with this campaign **must be** marked with a S00109 Campaign Identification Label.*

Complete the label and attach on a clean surface next to the vehicle identification number (VIN) plate.

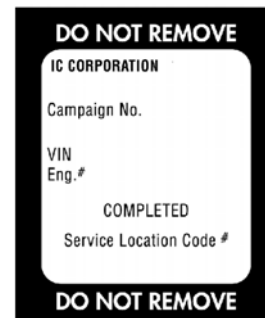

ADMINISTRATIVE/DEALER RESPONSIBILITIES (U.S. & POSSESSIONS)

Proceed immediately to make necessary correction to units in inventory. **All inventory vehicles subject to this recall campaign must be corrected prior to sale, transfer or delivery.** If vehicles have been sold or transferred and you are in receipt of Customer Notification Letters and Authorization for Recall Service cards for those vehicles, the transfer location or customer must be notified **IMMEDIATELY** from your dealer location.

Dealers must correct all vehicles subject to this campaign at no charge to the owner, regardless of mileage, age of vehicle, or ownership, from this time forward. The National Traffic and Motor Vehicle Safety Act, as amended, provides that each vehicle that is subject to a vehicle recall campaign must be adequately **repaired** within a reasonable time after the owner has tendered it for repair. A failure to adequately repair within **60 days** after a tender of a vehicle is prima facie evidence of failure to repair within a reasonable time. If the condition is not adequately repaired within 60 days, the owner may be entitled to **replacement** with an identical or reasonable equivalent vehicle at no charge, or to a **refund** of the purchase price less a reasonable allowance for depreciation.

However, consistent with the customer notification, dealers are expected to complete the repairs on the mutually agreed upon service date. To avoid having to replace an

owner vehicle or refund the purchase price, every effort must be made to promptly schedule an appointment with each owner to repair his or her vehicle as soon as possible.

During the recall process, a listing of owner names and addresses will be furnished to the involved dealers to enable dealers to follow up with owners and have the vehicles corrected. You must limit the use of this listing to this campaign because the list may contain information obtained from state motor vehicle registration records and the use of such motor vehicle registration data for purposes other than this campaign is a violation of law in several states.

POSSIBLE CUSTOMER REIMBURSEMENT

There may be an occasion when a customer was charged for repairs related to this Recall prior to the Recall being released. The customer letter contains a statement for the customer to contact the Dealer if they believe they are entitled to reimbursement costs. The Dealer should follow the Customer Reimbursement guidelines in Warranty Policy Letter 03-001G. The Warranty Procedures and Administrative Policies manual (CTS1100) is in the process of being updated to include the information in Policy Letter 03-001G.

WARRANTY CLAIMS

Refer to Dealer Warranty Manual for procedures to conduct Recall Campaigns.

It is important that the Recall Coding be completed properly to assist in processing the warranty claim. Complete instructions will be found in the Warranty Manual, Section 7-1. Special attention should be given to Items 39 through 44:

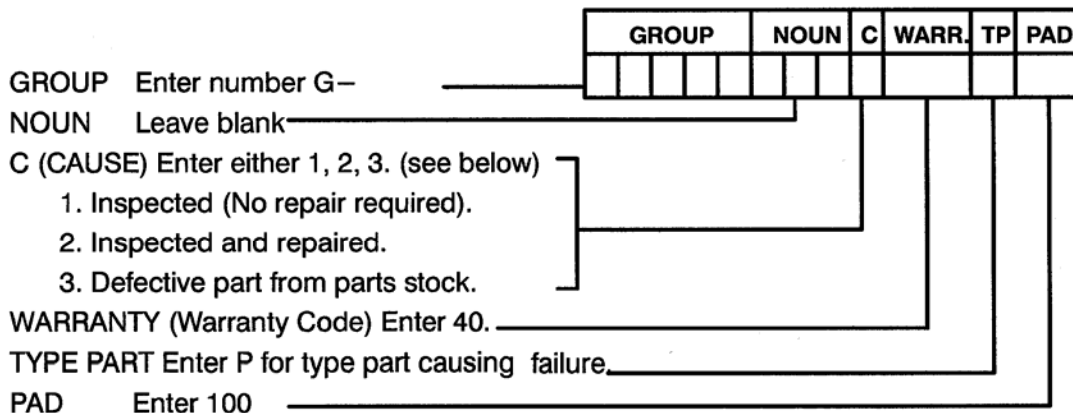

ADMINISTRATIVE/DISTRIBUTOR RESPONSIBILITY (EXPORT)

Proceed immediately to make necessary correction to units in inventory. All inventory vehicles subject to this recall campaign must be corrected prior to sale, transfer or

delivery. If vehicles have been sold or transferred and you are in receipt of Customer Notification Letters and Authorization for Recall Service cards for those vehicles, the transfer location or customer must be notified from your distributor location.

Export locations are to submit warranty claims in the usual manner making reference to this Recall number.

We ask for your full cooperation and follow-up to this important subject matter. If you have any questions or need further assistance, please contact the Regional Service Manager at your regional office.

INTERNATIONAL TRUCK AND ENGINE CORPORATION