

Subject: Norgren AMU Double-Check-Valves

Models Affected: Specific Freightliner Business Class M2 vehicles with optional work brake controls and Freightliner Custom Chassis S2 shuttle bus chassis and B2 school bus chassis (Thomas Built Buses Saf-T-Liner C2) with park brake release interlock controls manufactured between July 3, 2006, and November 3, 2006, with certain Norgren 12-18201-001 AMU double check valves.

General Information

Freightliner LLC, on behalf of its Freightliner Trucks Division and its wholly owned subsidiary, Freightliner Custom Chassis Corporation, has decided that a defect which relates to motor vehicle safety exists on the vehicles mentioned above.

There are approximately 600 vehicles involved in this campaign.

A machining error in the body of the affected double-check-valves, used in work brake controls or park brake interlock controls, may intermittently prevent the shuttle ball from properly functioning or closing. If this happens the service brake lights may not function consistently or the vehicle may roll away, resulting in possible property damage or injury.

The AMU double-check-valves will be replaced.

Additional Repairs

Dealers must complete all outstanding recall and field service campaigns prior to the sale or delivery of a vehicle. A Dealer will be liable for any progressive damage that results from its failure to complete campaigns before sale or delivery of a vehicle.

Owners may be liable for any progressive damage that results from its failure to complete campaigns within a reasonable time after receiving notification.

Work Instructions

Please refer to the attached work instructions. Prior to performing the campaign, check the vehicle for a completion sticker (Form WAR260).

Replacement Parts

Replacement kits are now available and can be obtained by ordering the kit number(s) listed below from your facing Parts Distribution Center.

If our records show your dealership has ordered any vehicles involved in campaign number FL491A, a list of the customers and vehicle identification numbers will be available on AccessFreightliner.com. Please refer to this list when ordering parts for this recall.

Table 1 - Replacement Parts for FL491

Campaign Number	Kit Number	Part Description	Part Number	Qty. per Kit	Suggested Wholesale*
FL491A	25-FL491-000	AMU Double-Check-Valve Kit	NRG 1749 001	1 ea	\$27.17 U.S. \$34.27 CAN
		Completion Sticker	WAR260	1 ea	

* Please charge all Direct Warranty Customers the above-listed price for the kit, as they are authorized to perform their own Recalls.

Table 1

Recall Campaign



May 2007
FL491A
NHTSA #07V-055

Removed Parts

Please follow Warranty Failed Parts Tracking shipping instructions for the disposition of all removed parts.

Labor Allowance

Table 2 - Labor Allowance

Campaign Number	Procedure	Time Allowed (hours)	SRT Code	Damage Code
FL491A	Remove and replace AMU double-check-valve module	0.6	996-0705A	000-Modifiedx

Table 2

IMPORTANT: When the recall has been completed, locate the base completion label in the appropriate location on the vehicle, and attach the red completion sticker provided in the recall kit (Form WAR260). If the vehicle does not have a base completion label, clean a spot on the appropriate location of the vehicle and first attach the base completion label (Form WAR259). If a recall kit is not required or there is no completion sticker in the kit, write the recall number on a blank sticker and attach it to the base completion label.

Claims for Credit

You will be reimbursed for your parts, labor, and handling by submitting your claim through the Warranty system within 30 days of completing this campaign. Please reference the following information in QuickClaim®:

- Claim type is **Recall**.
- In the FTL Authorization field, enter the campaign number and appropriate condition code (**FL491A**).
- In the Primary Failed Part Number field, enter **25-FL491-000**.
- In the Parts field, enter the appropriate kit number(s) as shown in the Replacement Parts Table.
- In the Labor field, first enter the appropriate SRT from the Labor Allowance Table. For administrative time, enter SRT 939-0010A for 0.3 hours.

IMPORTANT: ServicePro® must be viewed prior to performing the recall to ensure the vehicle is involved and the campaign has not been previously completed. Also, check for a completion sticker prior to beginning work.

Contact the Warranty Campaigns Department at (800) 547-0712, from 7:00 a.m. to 4:00 p.m. Pacific Time, Monday through Friday, Web inquiry at AccessFreightliner.com / Support / Submit an Inquiry, or the Customer Assistance Center at (800) 385-4357, after normal business hours, if you have any questions or need additional information.

To return excess kit inventory related to this campaign, U.S. dealers must submit a Parts Authorization Return (PAR) to the Memphis PDC. Canadian dealers must submit a PAR to their facing PDC. All kits must be in resalable condition. PAR requests must include the original purchase invoice number.

The letter notifying vehicle owners is included for your reference.

Please note that the National Traffic and Motor Vehicle Safety Act, as amended (Title 49, United States Code, Chapter 301), requires the owner's vehicle(s) be corrected within a reasonable time after parts are available to you. The Act states that failure to repair a vehicle within 60 days after tender for repair shall be prima facie evidence of an unreasonable time. However, circumstances of a particular situation may reduce the 60 day period. Failure to repair a vehicle within a reasonable time can result in either the obligation to (a) replace the vehicle with an identical or reasonably equivalent vehicle, without charge, or (b) refund the purchase price in full, less a reasonable allowance for depreciation. The Act further prohibits dealers from selling a vehicle unless all outstanding recalls are performed. Also, any lessor is required to send a copy of the recall notification to the lessee.

May 2007
FL491A
NHTSA #07V-055

Copy of Letter to Owner

Subject: Norgren AMU Double-Check-Valves

This notice is sent to you in accordance with the requirements of the National Traffic and Motor Vehicle Safety Act. This notice is also sent in accordance with the Canadian Motor Vehicles Safety Act.

Freightliner LLC, on behalf of its Freightliner Trucks Division and its wholly owned subsidiary, Freightliner Custom Chassis Corporation, has decided that a defect which relates to motor vehicle safety exists on specific Freightliner Business Class M2 vehicles with optional work brake controls and Freightliner Custom Chassis S2 shuttle bus chassis and B2 school bus chassis (Thomas Built Buses Saf-T-Liner C2) with park brake release interlock controls manufactured between July 3, 2006, and November 3, 2006, with certain Norgren 12-18201-001 AMU double-check-valves.

A machining error in the body of the affected double-check-valves, used in work brake controls or park brake interlock controls, may intermittently prevent the shuttle ball from properly functioning or closing. If this happens the service brake lights may not function consistently or the vehicle may roll away, resulting in possible property damage or injury.

The AMU double-check-valves will be replaced.

Parts are now available for authorized dealers to order. Contact your authorized dealer to arrange to have your vehicle(s) modified and to assure that parts are available at the dealer. To locate a dealer, search online at www.FreightlinerTrucks.com or contact the Warranty Campaigns Department for assistance.

When you contact your dealer, refer to campaign number **FL491A**. Once kit(s) are received at the dealership, the recall will take approximately an hour and will be performed at no charge to you.

IMPORTANT: When the recall has been completed, please ensure that a label has been affixed to your vehicle referencing **FL491A**.

If you do not own the vehicle that corresponds to the identification number(s) which appears on the Recall Notification, please return the notification to the Warranty Campaigns Department with any information you can furnish that will assist us in locating the present owner. If you have leased this vehicle, Federal law requires that you forward this notice to the lessee within 10 days.

If you are not able to have the defect remedied without charge and within a reasonable time, which is not longer than 60 days after you tender the vehicle for repair, please contact the Warranty Campaigns Department at (800) 547-0712, 7:00 a.m. to 4:00 p.m. Pacific Time, Monday through Friday, e-mail address WarrantyCampaigns@freightliner.com, or the Customer Assistance Center at (800) FTL-HELP or (800) STL-HELP, after normal business hours. You may also wish to submit a complaint to the Administrator, National Highway Traffic Safety Administration, 400 7th Street SW, Washington, DC 20590; or call the Vehicle Safety Hotline at (888) 327-4236 (TTY: 800-424-9153); or to <http://www.safercar.gov>. If your vehicle is involved in the Canadian portion, you may wish to notify Transport Canada, ASFAD, Place de Ville Tower C, 330 Sparks Street, Ottawa, ON K1A 0N5, or phone (800) 333-0510.

We regret any inconvenience this action may cause but feel certain you understand our interest in motor vehicle safety.

WARRANTY CAMPAIGNS DEPARTMENT

Enclosure

Recall Campaign

May 2007
FL491A
NHTSA #07V-055

Work Instructions

Subject: Norgren AMU Double-Check-Valves

Models Affected: Specific Freightliner Business Class M2 vehicles with optional work brake controls and Freightliner Custom Chassis S2 shuttle bus chassis and B2 school bus chassis (Thomas Built Buses Saf-T-Liner C2) with park brake release interlock controls manufactured between July 3, 2006, and November 3, 2006, with certain Norgren 12-18201-001 AMU double-check-valves.

Double-Check-Valve Module Replacement Procedure

1. Check the base label (Form WAR259) for a completion sticker for FL491 (Form WAR260) indicating this work has been done. On buses, the base label is usually located above the driver's window. On trucks, the base label is usually located on the passenger-side door about 12 inches (30 cm) below the door latch. If a sticker for FL491 is present, no further work is needed. If no sticker is present, go to the next step.
2. Shut down the engine, set the parking brake, and chock the tires.
3. Disconnect the batteries.
4. Drain the air reservoirs.

IMPORTANT: Clean the air management unit (AMU) and the area around it of all dirt and road debris before proceeding. Failure to do so can result in dirt or road debris between the modules and their seals, causing air leakage.

5. Find the double-check-valve module on the AMU. See **Fig. 1**.
6. Loosen the bolts on the L-bracket that secures the AMU to the mounting bracket. See **Fig. 2**. This will allow the AMU to separate, allowing for easy removal of the module.

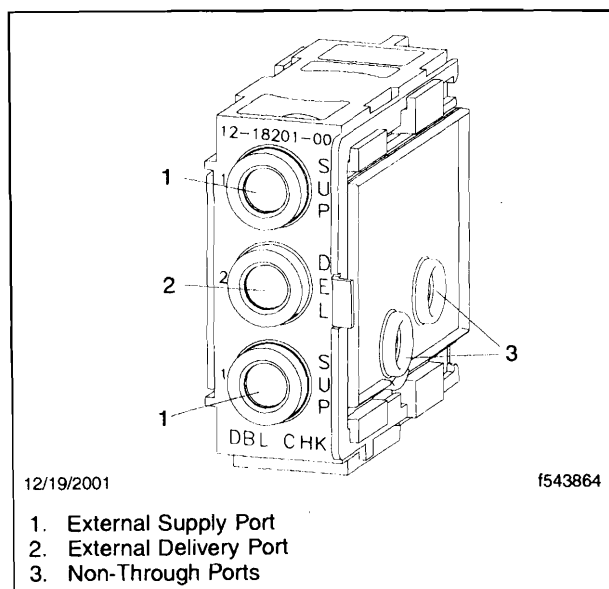

Fig. 1, Double-Check-Valve Module

7. Mark and disconnect the air lines from the double-check-valve module, part number 12-18201-001.
8. Pull out the locking keys from both sides of the module, and slide the AMU apart. See **Fig. 3**.
9. Remove the double-check-valve module.
10. Install the new seals from the kit on the sides of the new double-check-valve module.
11. Place the new module from the kit in position and slide the AMU modules together.
12. Push in the locking keys.
13. Install the air lines as previously marked.

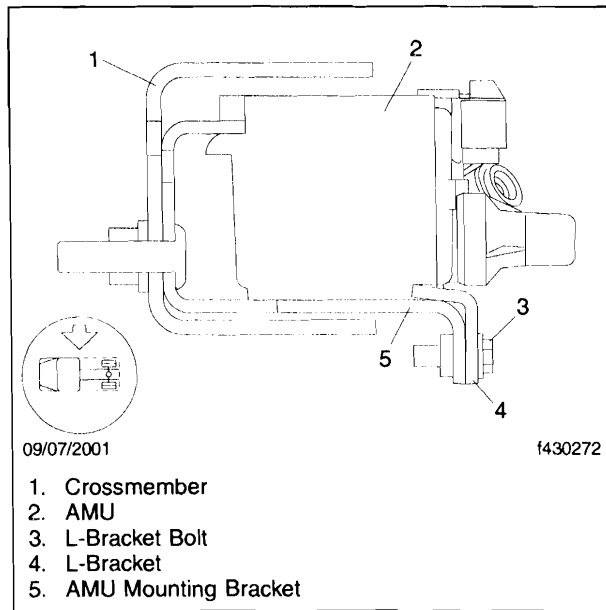

Fig. 2, Air Management Unit (AMU)

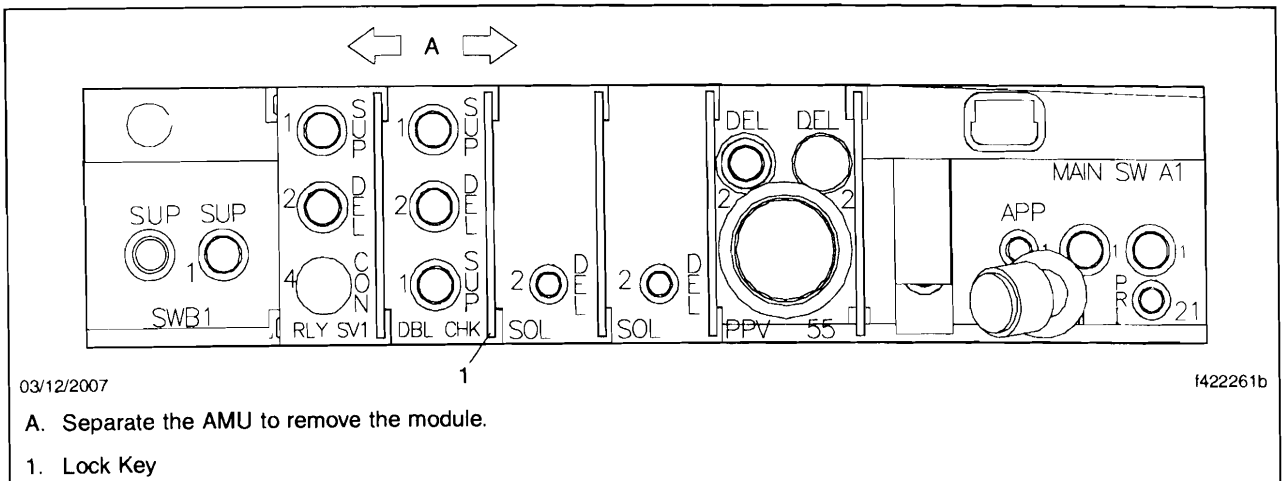

Fig. 3, AMU Module Replacement