

PREVOST

Saint-Nicolas, September 14, 2007

Mr. George H. Person
Chief, Recall Management Division
Office of Defects Investigation
National Highway Traffic Safety Administration
400, Seventh Street S.W.
Washington, DC 20590 USA
Fax: (202) 366-7882



SUBJECT: SAFETY RECALL NOTIFICATION

Dear Mr. Person,

As a coach manufacturer, Prevost Car Inc. advises you in accordance with your safety law, Part 573.6, that we have found a defect on some of our vehicles that does not meet the US Federal Motor Vehicle Standards and Regulations part 573.5.

The vehicles potentially affected by the defect are as follows:

MAKE: PREVOST

Model	VIN's	Manufacturing Dates
H3-41, H3-45 coaches VIP motorhomes MODEL YEAR: 2006-2007	From 2PCH3341X6101 0448 up to 2PCV334907C71 0963 incl.	Between October 2005 and June 2007
XLII-45 motorhomes XLII-45 Entertainer X3-45 coaches MODEL YEAR: 2006-2007	From 2PCY334946102 8868 up to 2PCY334907C72 9252 incl.	

The total number of vehicles potentially affected by the defect is estimated to be 686 in the U.S. and 165 in Canada, and the total number of the potentially affected vehicles in North America manufactured between October 2005 and June 2007 is 851.

The estimated percentage of the potentially affected vehicles that contain the defect is 100 % of the total manufactured quantity.

THE DEFECT MAY BE DESCRIBED AS FOLLOWS:

Bendix Commercial Vehicle Systems LLC has determined that a manufacturing defect exists in the internal rubber check valves inside the SR-7 spring brake modulating valves manufactured between November 4, 2005 and April 17, 2007. The component supplier of the internal check valve made unauthorized changes to its manufacturing process. The combination of eliminating the post cure process and not increasing the mold temperature can lead to the internal check valve rubber becoming deformed over time and potentially resulting in the check valve not properly seating. This condition can occur intermittently. The resulting leakage can cause a delay in the application of the spring brakes to park the vehicle after the operator pulls the dash valve button. The delayed parking brake application can occur without warning, leading to unintended vehicle rollaway. Normal service braking is not affected by this condition. Bendix estimates that approximately 5% of the potentially affected SR-7 valves may exhibit this condition. There have been no reports of any injuries related to this issue.

THE EVENTS THAT WERE THE BASIS FOR THE DETERMINATION OF THE EXISTENCE OF A SAFETY DEFECT ARE:

In August 2006, Bendix received a returned SR-7 valve with a report of leakage consistent with delayed application of parking brakes. Bendix performed laboratory tests on the part, but could not duplicate the

PRÉVOST CAR INC.

MANUFACTURIER D'AUTOCARS • HIGHWAY COACH MANUFACTURER
AFTER-SALES SERVICE DEPARTMENT / SERVICE APRÈS-VENTE
850, ch. Olivier, Saint-Nicolas, (Qc), Canada, G7A 2N1 • Tél. : (418) 831-2046, Fax : (418) 831-9301

PREVOST

leakage. In October 2006, Bendix received two other SR-7 valves with reported leakage. In December 2006, Bendix began analyzing all SR-7 valves returned under warranty but was not able to determine whether any defect existed. In February 2007, the Bendix Product Integrity Committee (PIC) opened its investigation of the issue. In March 2007, Bendix was informed by a vehicle manufacturer that it had duplicated the leakage issue on a vehicle, and representatives of Bendix visited the vehicle manufacturer's plant to investigate the matter and to obtain the affected valve for further evaluation at Bendix laboratories. Until this point Bendix was not able to isolate the primary contributing factors to the leakage. The investigation was further complicated by reported leakage in some SR-7 valves related to the Parker single check valve issue identified in a separate Defect Report filed with NHTSA on this date. In March 2007, Bendix received a report of a vehicle rollaway incident in the field involving minor property damage. In April, 2007 Bendix determined its supplier made unauthorized manufacturing changes by eliminating the post-cure process. During April and May, Bendix confirmed the impact of the post-cure process and the valve molding temperature on the functioning of the internal check valve. On May 31, 2007, Bendix decided that a defect that relates to motor vehicle safety exists with respect to the potentially affected SR-7 spring brake modulating valves.

MEASURES TO BE TAKEN TO REPAIR THE DEFECT:

Prevost Safety Recall Sr07-11, reproducing Bendix SR-7 Valve Recall Campaign No. 07E-037 will explain the complete procedure required. All vehicle owners with SR-7 valve built between November 4, 2005 and April 17, 2007 (inclusive) will be asked to replace the internal check valve cartridge.

As requested in paragraph 573.2 (8), three (3) copies of the letter that our customers (Defect Notification) will receive on that matter, and three (3) copies of Safety recall no. 07-11 are enclosed for your perusal.

If you require any information on that campaign, do not hesitate to contact us.

Truly yours,

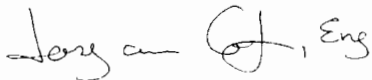

Josyane Côté, Eng.

Technical Publications Manager

PRÉVOST CAR INC.

MANUFACTURIER D'AUTOCARS • HIGHWAY COACH MANUFACTURER
AFTER-SALES SERVICE DEPARTMENT / SERVICE APRÈS-VENTE

850, ch. Olivier, Saint-Nicolas, (Qc), Canada. G7A 2N1 • Tél. : (418) 831-2046, Fax : (418) 831-9301



PREVOST

ENREGISTRÉ - REGISTERED
ISO 9001 & ISO 14001

**SAFETY
 RECALL**

Sr07-11



DATE : September-2007	SECTION : 12
SUBJECT : BENDIX SR-7 SPRING BRAKE MODULATING VALVE – INTERNAL CHECK VALVE RETROFIT	

APPLICATION

Model	VIN
XL2-45 motorhomes MTH XL2-45 Entertainer X3-45 coaches Model Year : 2006 - 2007	 From 2PCY33494 61028868 up to 2PCY33490 7C729252 incl.
H3-41 & H3-45 coaches VIP motorhomes Model Year : 2006 - 2007	From 2PCH3341X 61010448 up to 2PCV33490 7C710963 incl.
<p>This Safety Recall does not necessarily apply to all the above-mentioned vehicles, some vehicles may have been modified before delivery. The owners of the vehicles affected by this recall will be advised by a letter indicating the Vehicle Identification Number (VIN) of each vehicle concerned.</p>	

DESCRIPTION

Bendix Commercial Vehicle Systems LLC has determined that a manufacturing defect exists in the internal rubber check valves inside the SR-7 spring brake modulating valves manufactured **between November 4, 2005 and April 17, 2007**. The component supplier of the internal check valve made unauthorized changes to its manufacturing process leading to the internal check valve rubber becoming deformed over time and potentially resulting in the check valve not properly seating. This condition can occur intermittently. The resulting leakage can cause a delay in the application of the spring brakes to park the vehicle after the operator pulls the parking brake control valve. The delayed parking brake application can occur without warning, leading to unintended vehicle rollaway. Normal service braking isn't affected by this condition.

Prevost asks to its customers to perform the following Bendix SR-7 valve recall campaign identification guidelines (Part 1). **Only if the spring brake modulating valve is identified as subject to this recall, perform Bendix's internal check valve retrofit procedure described in this bulletin (Part 2).**

Reference: Bendix Recall Campaign No.: 07E-037

MATERIAL

Kit #643385 includes the following parts:

Description	Qty
Internal Check Valve Cartridge <ul style="list-style-type: none"> ▪ Plastic guide with O-ring ▪ Spring ▪ Check valve 	1
O-ring (extra)	1
Screw (extra)	1
Green tie wrap	1

NOTE

Material can be obtained through regular channels.

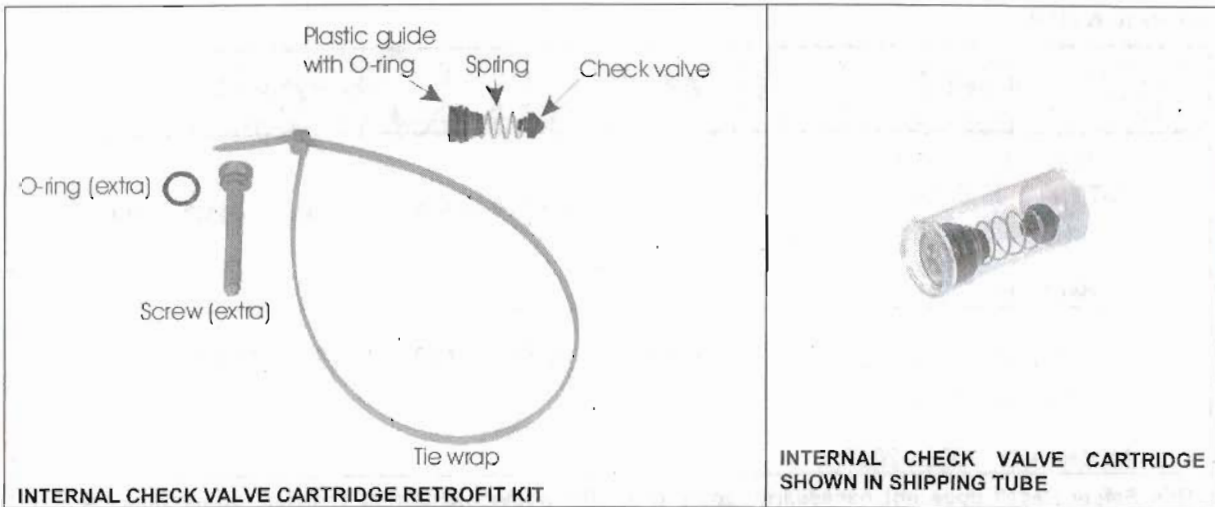

PROCEDURE



DANGER

Park vehicle safely, apply parking brake, stop engine and set battery master switch(es) to the OFF position prior to working on the vehicle.

Part 1 - Identification



FIGURE 1: BENDIX SR-7 LOCATION ON H3, X3 AND XLII MTH SERIES VEHICLES (TYPICAL)

1. Locate the SR-7 spring brake modulating valve (see figure 1 & 2). Typically, the SR-7 valve is located between the drive and the tag axle, behind the L.H. side rear fender (H3 series coaches) or above the drive axle in the rear underframe (X3 & XLII MTH series).
2. Remove the L.H. side rear fender (H3 series coaches) or raise the vehicle to access the spring brake modulating valve (X3 & XLII MTH series).

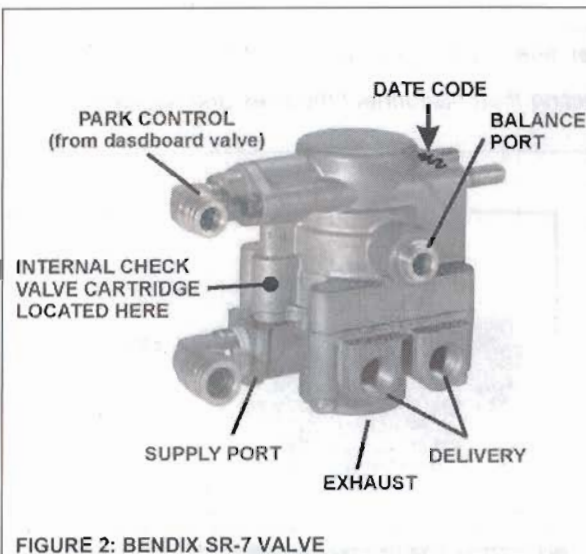

FIGURE 2: BENDIX SR-7 VALVE

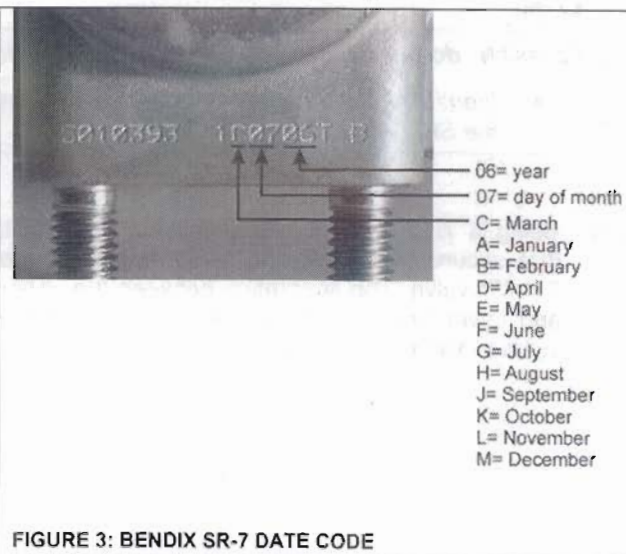

FIGURE 3: BENDIX SR-7 DATE CODE

3. Check the date code found on the SR-7 valve body (see figure 3). If the SR-7 valve was manufactured between **November 4, 2005 and April 17, 2007(inclusive)**, it is necessary to retrofit the internal check valve cartridge as described in Part 2.

NOTE

You will need a small telescoping mirror to see the date code on the SR-7 valve body. For X3 & XLII series vehicles, remove the two mounting nuts that secure the valve to the underframe and move the valve slightly to ease sight on the date code.



Part 2 – Internal check valve retrofit

INTERNAL CHECK VALVE REMOVAL

1. Drain the air pressure from primary and secondary air tanks.
2. Clean the SR-7 valve body thoroughly with water jet and dry with pressurized air.



CAUTION

It is very important to properly clean the valve body in order to prevent dirt from entering inside the valve body during separation of the upper and lower halves.

3. For X3 & XLII series vehicles, remove the two mounting nuts that secure the valve to the underframe.

NOTE

If possible, **do not** disconnect air lines and fittings. If air lines have to be disconnected :

- Identify and mark all air lines before disconnecting then disconnect the lines and hoses from the SR-7 spring brake modulating valve.

4. Using a 7/16" wrench, remove the four screws that secure the upper and lower bodies of the SR-7™ valve. The separation between the upper and lower body should be approximately three inches to allow adequate room to install this kit.

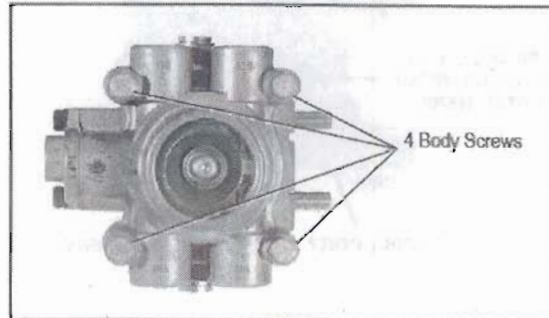

5. Locate the plastic guide in the upper body of the SR-7™ valve directly above the supply port. The o-ring seal from the lower body may stick to the plastic guide when the bodies are separated. If so, remove it from the guide and place it back into the lower body. An extra o-ring has been included in this kit in the event that the o-ring is lost or damaged during servicing.
6. Remove the plastic guide, spring and check valve from the valve bore and discard. *Note: The check valve may stick to its seat in the upper body. Be sure that all of the components are removed before going to the next step.*

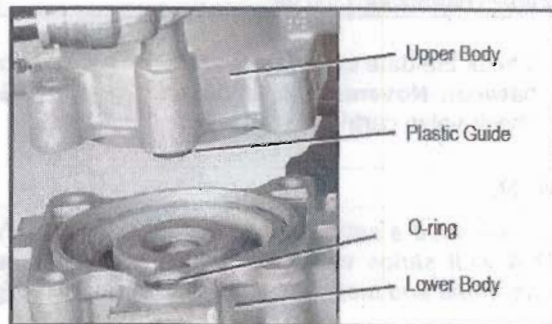

CARTRIDGE INSTALLATION

1. Insert the replacement cartridge in the bore where the check valve, spring and plastic guide were removed. *Note: Be sure to remove the replacement cartridge from its shipping tube prior to installation.*

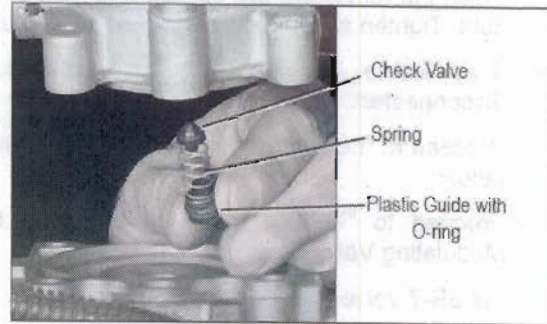

2. Push the cartridge into position until it stops.

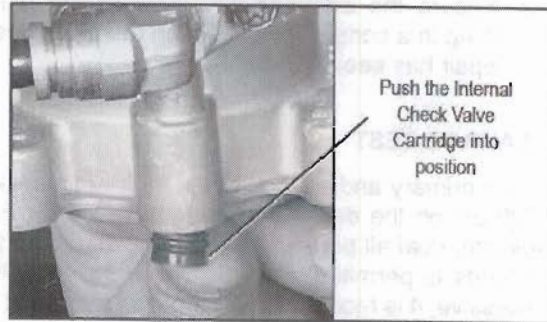

3. A portion of the plastic guide in the cartridge will stick out as shown. **DO NOT FORCE THE CARTRIDGE FURTHER INTO THE BORE.**
4. Before reassembling the body halves together, clean inside the lower body with pressurized air in order to prevent dirt from entering the valve body.

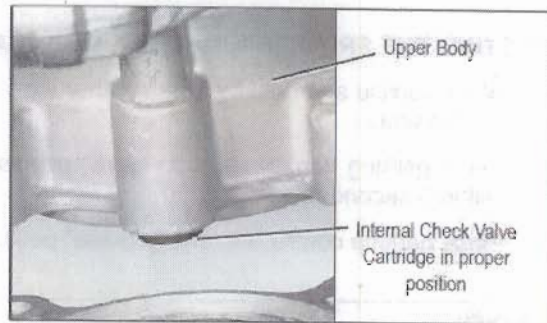

5. Align the valve lower body with the upper body. Push the body halves together.
6. Insert two of the four screws (finger tight) into the lower body mounting holes closest to the supply port first. This will help with alignment. One extra screw is included in this kit in the event one is lost during installation.



7. Insert the remaining two screws and tighten finger tight. Tighten all four screws to **80-100 in·lbs.**
8. If applicable, reconnect **any** air lines that were disconnected.
9. Proceed to "Leakage Test" as per the instructions below.
10. Proceed to "Testing the SR-7™ Spring Brake Modulating Valve."
11. Fix SR-7 valve to underframe.
12. Secure the enclosed tie wrap on the valve or fitting in a conspicuous location to identify the field repair has been performed.

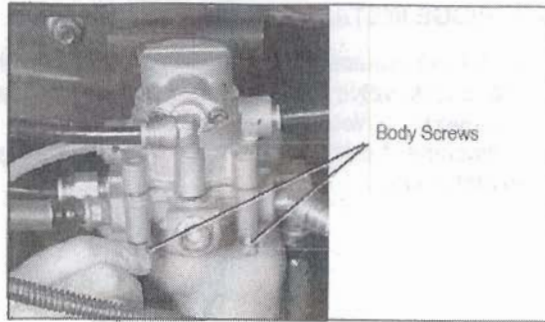

LEAKAGE TEST

Close primary and secondary air tank drain cocks. Charge air brake system to governor cut-out pressure (120 psi on the dashboard gauge). Place the park control valve in the "release" position; using a soap solution, coat all ports including the exhaust port and external check valve, if applicable. A 1" bubble in 3 seconds is permitted (175 SCCM). If the SR-7™ valve does not function as described, or if leakage is excessive, it is recommended that it be replaced with a new unit available from Prevoist Parts.

TESTING THE SR-7 SPRING BRAKE MODULATING VALVE

1. Block vehicle and hold by means other than vehicle brakes. Charge air brake system to governor cut-out pressure.
2. Place parking control valve in "park" position. Observe that spring brake actuators apply promptly, within 3 seconds.
3. Place parking control valve in "release" position. Observe that spring brake actuators release fully.

NOTE

For the two previous steps, you can proceed as follow:

- *Drive the vehicle at very low speed (3 to 6 mph) and then apply the parking brake.*
- *Apply the parking brake. Place the transmission to D (drive) position and press gently on the accelerator pedal (not faster than 1000 rpm). Vehicle should not move.*
- *Apply the parking brake. Place the transmission to D (drive) position and press gently on the accelerator pedal (not faster than 1000 rpm). Using the parking brake control valve, release the parking brake. Vehicle should move promptly.*

4. Prior to returning the vehicle to service, make certain all components and systems are restored to their proper operating condition.

WARRANTY

This modification is covered by Prevost Car's normal warranty. We will reimburse you the parts and one hour (1.0) of labor upon receipt of the parts and a completed A.F.A. form on which you must specify as per "Safety Recall 07-11". **You also have to fill the "Safety Recall Certification Sheet" provided with this bulletin and return it with your A.F.A. form to be reimbursed.**

Parts disposition:

- You must return parts to Prevost Car with A.F.A. for full reimbursement.



PREVOST

**Safety Recall
Certification Sheet
(Ref: Sr07-11)**

ENREGISTRÉ - REGISTERED
ISO 9001 & ISO 14001



SERIAL NUMBER: _____

PERFORMED BY		OWNER/OPERATOR	
We hereby certify that Safety Recall Instructions with regard to Safety Recall #07-11 have been performed.			
Name: _____		Name: _____	
Addr: _____		Addr: _____	
Phone: _____		Phone: _____	
Fax: _____		Fax: _____	
Signature : _____		Signature : _____	
Date: _____		Date: _____	

If the information mentioned above is incorrect or you are not the owner of this vehicle anymore, please fill this section and return to sender.

NEW OWNER: _____

BUSINESS: _____

ADDRESS (including County): _____

TELEPHONE: _____ **FAX:** _____

**Please return this completed document with your
A.F.A. form**

PREVOST

September 14, 2007

DEFECT NOTIFICATION

Dear Customer:

This notice is sent to you in accordance with the requirements of the National Traffic and Motor Vehicle Safety Act of U.S.A.

Prevost Car Inc. has decided that a defect which relates to motor vehicle safety exists in certain 2006 - 2007 H3-41 & H3-45 coaches, VIP motorhomes, XLII-45 motorhomes and Entertainers and X3-45 coaches.

Bendix Commercial Vehicle Systems LLC has determined that a manufacturing defect exists in the internal rubber check valves inside the SR-7 spring brake modulating valves manufactured between November 4, 2005 and April 17, 2007. The component supplier of the internal check valve made unauthorized changes to its manufacturing process leading to the internal check valve rubber becoming deformed over time and potentially resulting in the check valve not properly seating. This condition can occur intermittently. The resulting leakage can cause a delay in the application of the spring brakes to park the vehicle after the operator pulls the parking brake control valve. The delayed parking brake application can occur without warning, leading to unintended vehicle rollaway. Normal service braking isn't affected by this condition.

Model	Serial numbers
H3-41, H3-45 coaches VIP motorhomes MODEL YEAR: 2006-2007	From 2PCH3341X6101 0448 up to 2PCV334907C71 0963 incl.
XLII-45 motorhomes, XLII-45 Entertainer X3-45 coaches MODEL YEAR: 2006-2007	From 2PCY334946102 8868 up to 2PCY334907C72 9252 incl.

CORRECTIVE ACTIONS:

Prevost Safety Recall Sr07-11 explains the complete procedure required. Federal regulation requires that any vehicle lessor receiving this recall notice must forward a copy of this notice to the lessee within ten days.

REPORTING REQUIREMENT:

In order to verify and document the corrective action taken on your vehicle(s) pursuant to the requirements of the Federal Motor Vehicle Safety Regulations, we are enclosing a "**SAFETY RECALL CERTIFICATION**" sheet. When the vehicle(s) is (are) repaired, this (these) sheet(s) must be completed and returned to PREVOST CAR INC. head office.

LABOR & PARTS REIMBURSEMENT:

Prevost Car Inc. will reimburse you parts and labor incurred.

Federal laws require that you be informed of your right to notify the Department of Transportation if you are unable to have the defect remedied without charge. The address for this purpose is:

National Highway Traffic Safety Administration
Washington, DC 20590
USA
Auto Safety Hotline: 1-888-327-4236.

If any assistance is required, please contact one of the Prevost Service Centers, your Prevost Service Representative or the After-Sales Service department.

We regret any inconvenience which this situation may cause you. However, we are concerned about your safety; rest assured that PREVOST CAR INC. is making all efforts to remedy the defect as quickly as possible in the interest of motor vehicle safety.

Truly yours,



Josyane Côté, Eng.
Technical Publications Manager.

PRÉVOST CAR INC.

MANUFACTURIER D AUTOCARS • HIGHWAY COACH MANUFACTURER
AFTER-SALES SERVICE DEPARTMENT / SERVICE APRES-VENTE
850. ch. Olivier. Saint-Nicolas. (Qc). Canada. G7A 2N1 • Tél. : (418) 831-2046, Fax : (418) 831-9301