



# Recall Action Notice Service Bulletin 378 December 2006

**Affected Model** ..... **Sprint ST (1050cc) and Sprint ST (1050cc) ABS**

**VIN Range** ..... **VIN 221423 to VIN 287719, and from VIN 290144 to 298255**

**Markets** ..... **All**

**Subject** ..... **Drag Link to Drop Link Bolt, sleeve and nut**

### Background Information

In-service quality feedback has identified a potential problem with the drag link to drop link bolt (part number T3330335), which could result in the bolt becoming bent or fractured.

Dealers are required to remove and discard the drag link to drop link bolt, nut, bearing sleeve and spacers, and install a new, longer bearing sleeve with hardened washers, new spacers and a new bolt and nut.

In addition, dealers are required to inspect the bolt for any signs of bending once it has been removed. If the bolt is bent, dealers are required to replace the drag link rear bearing and seals with new parts.

### Customer Contact Instructions

**UK:** Triumph Motorcycles Limited will write directly to the UK owners of the affected machines instructing them to contact their nearest dealer to arrange for the replacement of the drag link to drop link bolt, bearing sleeve, spacers and nut, and potential replacement of the drag link rear bearing and seals. For vehicles in dealer stock, the recall **MUST** be actioned before delivery to the customer.

**Overseas:** Triumph subsidiaries and distributors must instigate a recall action in their country in accordance with the national recall code of practice.

### Identification of Affected Motorcycles

Sprint ST (1050cc) and Sprint ST ABS (1050cc) models from VIN 221423 to VIN 287719, and from VIN 290144 to 298255.

### Warranty Claim Instructions

Fault code ..... 020560991

Repair code - Drag link bolt and nut, ground sleeve, spacers & hardened washers only ..... 99378

Repair code - Drag link bolt and nut, ground sleeve, spacers, hardened washers, bearing & seals. . . . 993781

### Repair time allowance (including Admin)

Drag link bolt and nut, ground sleeve, spacers & hardened washers only ..... 0.31 hrs

Drag link bolt and nut, ground sleeve, spacers, hardened washers, bearing & seals. ....0.51 hrs

## Parts Information

Parts required..... 1 x T3330335 - Bolt, Skt Hd, M10 x 100  
1 x T3350005 - Nut  
1 x T2050102 - Bearing Sleeve  
2 x T2050103 - Spacer  
2 x T3550166 - Washer, M10, Hardened

Additional parts (Only if required) 1 x T3800155 - Bearing, Needle Roller  
2 x T3600122 - Seal, Oil  
1 x T3350005 - Nut

Parts ordering instructions ..... Orders should be placed using the normal parts ordering procedure.

Parts return instructions ..... Dealer to retain all parts for 90 days. All parts must be stored in a secure, non-public accessed area and correctly identified with a completed warranty label. Thereafter the parts must be rendered unusable prior to scrapping. It is suggested the bolt is damaged by placing the threaded portion in a vice and the threads crushed, and then the bolt bent over. Similarly, the nut, bearing sleeve, spacers and if replaced, the bearing and seals should be crushed in a vice until they are unusable.

Service tools ..... T3880253 - Tool, Extract, Drag Link Bearing  
T3880254 - Tool, Insert, Drag Link Bearing

T3880253 - Tool, Extract, Drag Link Bearing

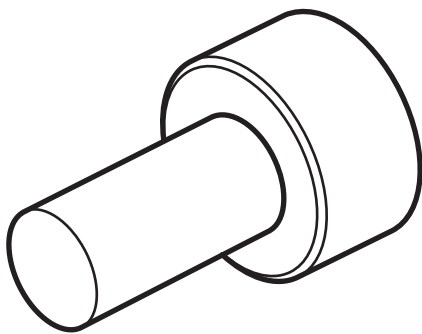

T3880254 - Tool, Insert, Drag Link Bearing

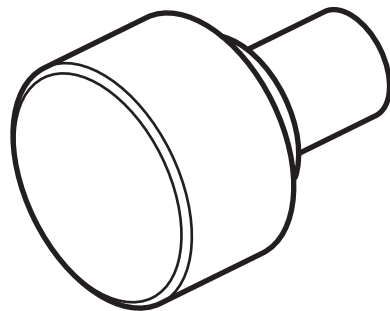

## Other Instructions

Once completed, please mark the service record book that the requirements of this bulletin have been complied with.

## Replacement Procedure

Replace the drag link to drop link bolt, nut, bearing sleeve and spacers, and inspect and if necessary replace the drag link rear bearing and seals, following the procedure listed below:

### **Warning**

Throughout the following procedure, ensure that the motorcycle is stabilised and adequately supported to prevent the risk of injury from the motorcycle falling.

### **Warning**

Failure to tighten any of the fasteners to the correct torque specification may result in loss of motorcycle control and an accident.

## Removal

1. Raise and support the rear of the motorcycle beneath the frame or engine. Position a block to support the rear wheel.
2. Remove the nut and bolt securing the drag link to the drop link. Collect the washer from under the bolt head and retain for re-use.

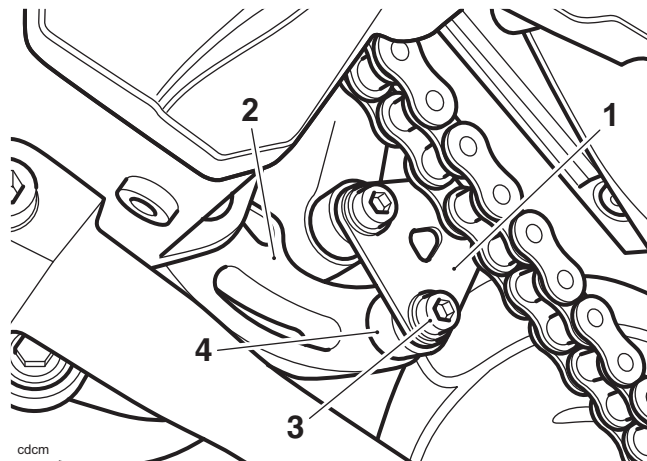

1. **Drop link**
2. **Drag link**
3. **Drag link to drop link bolt**
4. **Spacer (left hand shown)**

3. Release the drag link from the drop link and collect the spacers.

4. Remove the bearing sleeve from the drag link.

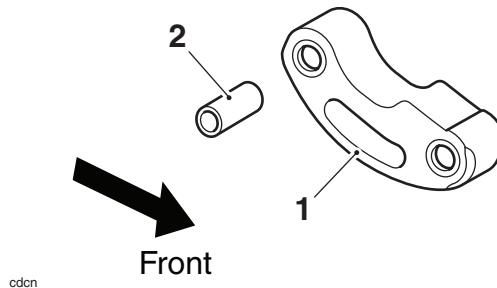

1. Drag link (shown removed from the motorcycle for clarity)
2. Bearing sleeve

5. Discard the nut, bolt, bearing sleeve and spacers, noting the parts return instructions given on page 1.

## Inspection

1. Inspect the bolt for any signs of bending. If the bolt is bent, the drag link rear bearing and seals must be replaced.

### Note:

- If the bolt shows no signs of bending, the drag link rear bearing or seals **DO NOT** need to be replaced. However the bolt, bearing sleeve, spacers and nut **MUST** be replaced in all cases, even if they appear to be in good condition.

## Bearing Replacement (only if required)

1. Remove the drag link as follows:
  - Remove the bolt and nut (discard the nut) securing the drag link to the frame.
  - Detach the drag link from the frame.
2. Remove the two rear drag link seals.

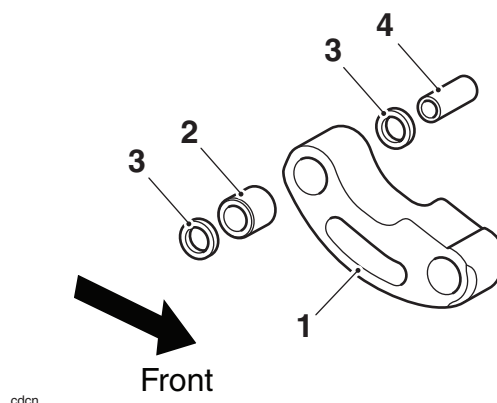

1. Drag link
2. Rear bearing
3. Seals
4. Bearing sleeve

## **Warning**

When using a press, always wear overalls, eye, face and hand protection. Objects such as bearings frequently break-up under load and the debris caused during break-up may cause damage and injury to unprotected parts of the body.

Never wear loose clothing which could become trapped in the press and cause a crushing injury to the hand, arms or other parts of the anatomy.

3. Transfer the drag link to a press, and using service tool T3880253, press out the rear bearing through the drag link as shown below. Collect the bearing as it is released, and remove the tool from the drag link.

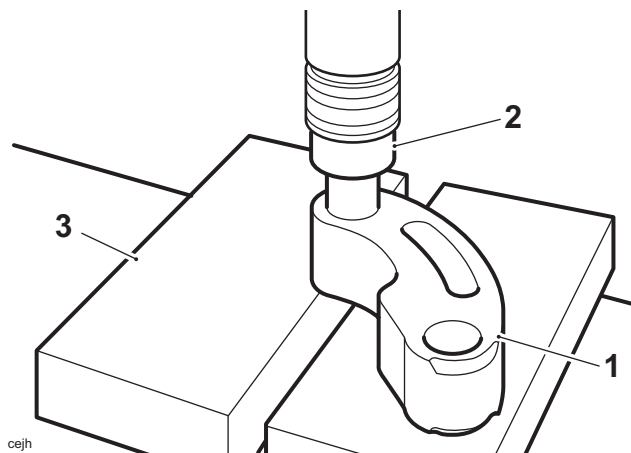

1. Drag link
2. Tool T3880253
3. Press bars

## **Caution**

The bearing must be installed with the marked side of the bearing facing towards service tool T3880254. Failure to follow this instruction will result in damage to the bearing.

4. Position the new bearing to service tool T3880254, with the marked side of the bearing facing towards the tool.

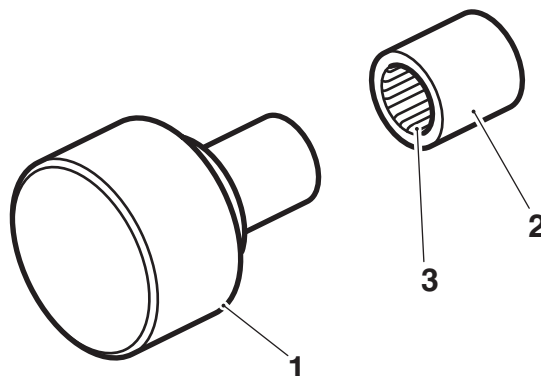

1. Tool T3880254
2. Bearing (shown with marked side facing the service tool)
3. Bearing markings

**Warning**

When using a press, always wear overalls, eye, face and hand protection. Objects such as bearings frequently break-up under load and the debris caused during break-up may cause damage and injury to unprotected parts of the body.

Never wear loose clothing which could become trapped in the press and cause a crushing injury to the hand, arms or other parts of the anatomy.

5. Position the service tool and bearing to the press as shown below, and press in the new bearing until the tool contacts the drag link.

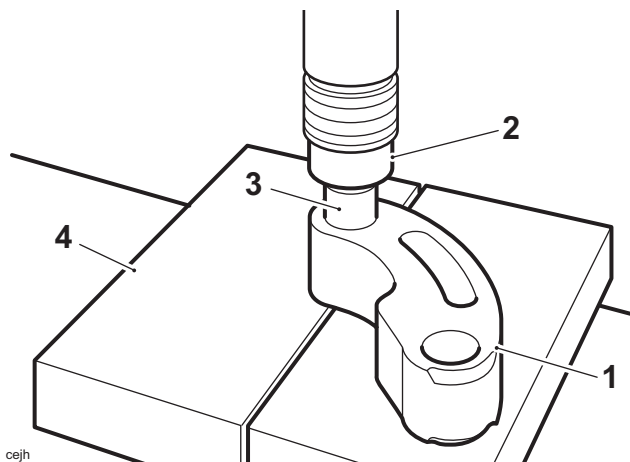

1. Drag link
2. Tool T3880254
3. Bearing
4. Press bars

6. Install two new seals, with the marked side of the seal facing outwards, until they are flush with the surface of the drag link.

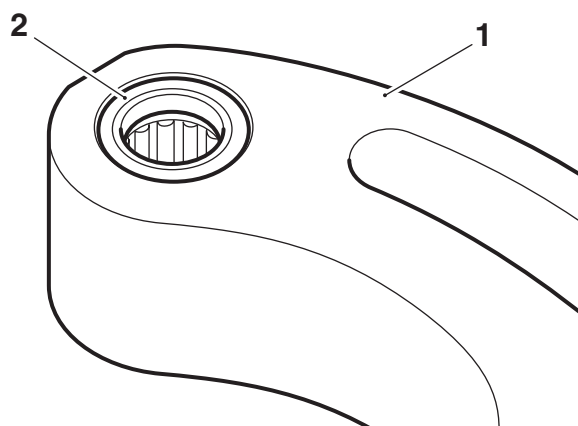

1. Drag link
2. Seal (flush with surface of drag link)

**Note:**

- **This bulletin does not include replacement of the front drag link bearing, seals or bearing sleeve. Replacement of these items, if required, must be treated as a separate repair item, and claimed using a separate warranty claim.**
7. Remove the front bearing sleeve and inspect the front bearing and seals for damage or wear. Replace any damaged or worn components. Lubricate the front bearing and seals with grease to NLGI 2 specification (we recommend Mobil grease HP222). Clean and refit the bearing sleeve.

**Drag link Installation (only if the bearing or seals have been replaced)**

1. Position the drag link in the correct orientation to the frame and refit the original front bolt. Fit a new nut (part number T3350005) and tighten to **48 Nm**.

**Assembly**

1. Lubricate the rear bearing with grease to NLGI 2 specification (we recommend Mobil grease HP222).
2. Lubricate the rear seal's knife-edges with grease to NLGI 2 specification (we recommend Mobil grease HP222).
3. Install the new, longer bearing sleeve (part number T2050102) to the drag link, ensuring it protrudes evenly through either side of the drag link.

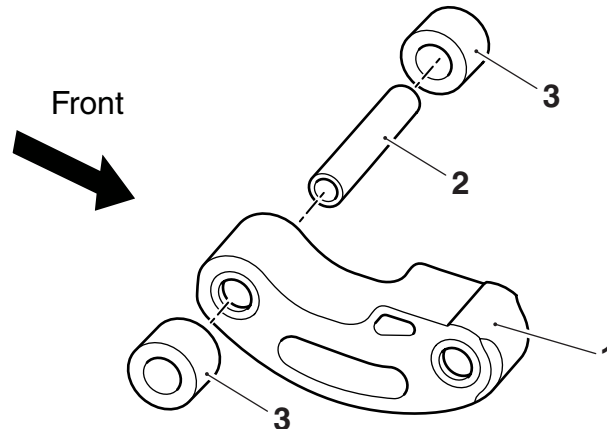

1. **Drag link (shown with the bearing and seals assembled)**
  2. **Bearing sleeve**
  3. **Spacers**
4. Lubricate the exposed outer surface of the bearing sleeve with grease to NLGI 2 specification (we recommend Mobil grease HP222).

5. Fit the two spacers (part number T2050103) to the outside of the bearing sleeve (one on each side) as shown below.

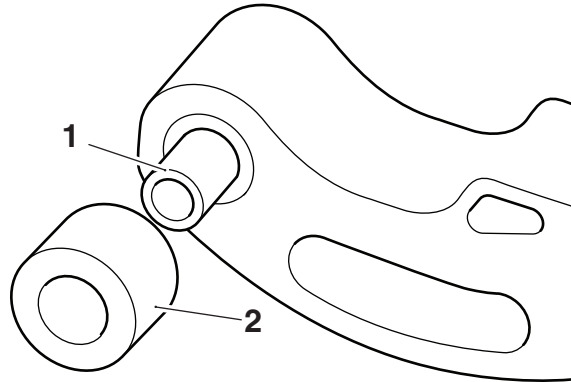

1. New bearing sleeve
2. Spacer (Right hand shown)

6. Align the drag link to the drop link and fit a new hardened washer to each end of the bearing sleeve, between the side plates of the drop link.

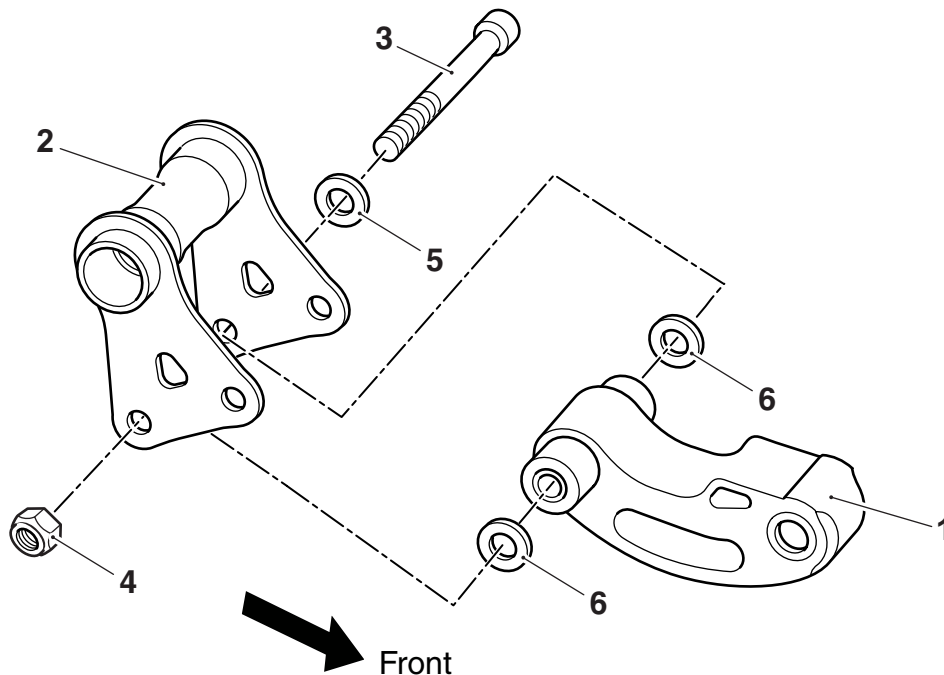

1. Drag link (shown with the bearing sleeve and spacers assembled)
2. Drop link
3. Drag link to drop link bolt
4. Nut
5. Hardened washer (removed from original bolt)
6. New hardened washers

7. Fit the hardened washer (removed from the original bolt) to the new bolt (part number T3330335).

8. Install the new drag link to drop link bolt (part number T3330335) from the left hand side, fit a new nut (part number T3350005) and tighten to **48 Nm**.

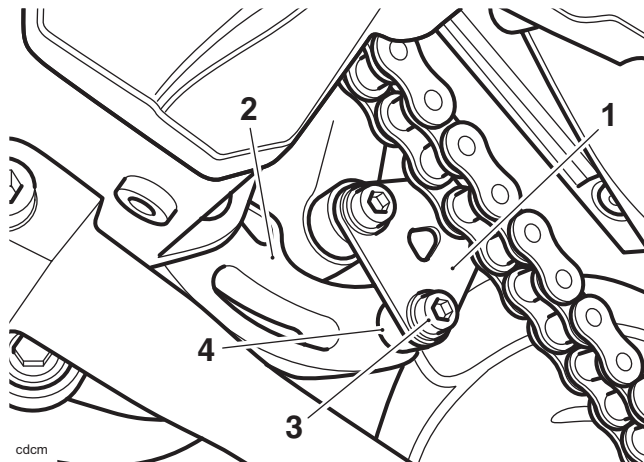

1. Drop link
2. Drag link
3. Drag link to drop link bolt
4. Spacer (left hand shown)

9. Lower the motorcycle to the ground and remove the support.

## Circulation

(Initial and date when read and return to central file holder)

| Service Manager | Parts Manager | Sales Manager | Workshop Supervisor | Technician 1 | Technician 2 |
|-----------------|---------------|---------------|---------------------|--------------|--------------|
|                 |               |               |                     |              |              |



# Recall Action Notice Service Bulletin 379 December 2006

**Affected Model** ..... Sprint ST (1050cc) and Sprint ST (1050cc) ABS  
**VIN Range** ..... VIN 287720 to VIN 290143  
**Markets** ..... All  
**Subject** ..... Drag Link to Drop Link Bolt, Sleeve and Nut -  
 Vehicles with the drag link bolt installed from the  
 right hand side

## Background Information

In-service quality feedback has identified a potential problem with the drag link to drop link bolt (part number T3330335), which could result in the bolt becoming bent or fractured.

Dealers are required to remove and discard the drag link to drop link bolt, nut, bearing sleeve and spacers, and install a new, longer bearing sleeve with hardened washers, new spacers and a new bolt and nut.

### Note:

- The bolt will have been installed from the right hand side, and will require removal of the intermediate exhaust pipe in order to remove it.

In addition, dealers are required to inspect the bolt for any signs of bending once it has been removed. If the bolt is bent, dealers are required to replace the drag link rear bearing and seals with new parts.

## Customer Contact Instructions

**UK:** Triumph Motorcycles Limited will write directly to the UK owners of the affected machines instructing them to contact their nearest dealer to arrange for the replacement of the drag link to drop link bolt, bearing sleeve, spacers and nut, and potential replacement of the drag link rear bearing and seals. For vehicles in dealer stock, the recall **MUST** be actioned before delivery to the customer.

**Overseas:** Triumph subsidiaries and distributors must instigate a recall action in their country in accordance with the national recall code of practice.

## Identification of Affected Motorcycles

Sprint ST (1050cc) and Sprint ST ABS (1050cc) models from VIN 287720 to VIN 290143.

## Warranty Claim Instructions

Fault code ..... 020560992

Repair code - Drag link bolt and nut, ground sleeve, spacers & hardened washers only ..... 99379

Repair code - Drag link bolt and nut, ground sleeve, spacers, hardened washers, bearing & seals ... 993791

## Repair time allowance (including Admin)

Drag link bolt and nut, ground sleeve, spacers & hardened washers only ..... 0.91 hrs

Drag link bolt and nut, ground sleeve, spacers, hardened washers, bearing & seals. .... 1.11 hrs

## Parts Information

Parts required..... 1 x T3330335 - Bolt, Skt Hd, M10 x 100  
1 x T3350005 - Nut  
1 x T2050102 - Bearing Sleeve  
2 x T2050103 - Spacer  
2 x T3550166 - Washer, M10, Hardened

Additional parts (Only if required) 1 x T3800155 - Bearing, Needle Roller  
2 x T3600122 - Seal, Oil  
1 x T3350005 - Nut

Parts ordering instructions ..... Orders should be placed using the normal parts ordering procedure.

Parts return instructions ..... Dealer to retain all parts for 90 days. All parts must be stored in a secure, non-public accessed area and correctly identified with a completed warranty label. Thereafter the parts must be rendered unusable prior to scrapping. It is suggested the bolt is damaged by placing the threaded portion in a vice and the threads crushed, and then the bolt bent over. Similarly, the nut, bearing sleeve, spacers and if replaced, the bearing and seals should be crushed in a vice until they are unusable.

Service tools ..... T3880253 - Tool, Extract, Drag Link Bearing  
T3880254 - Tool, Insert, Drag Link Bearing

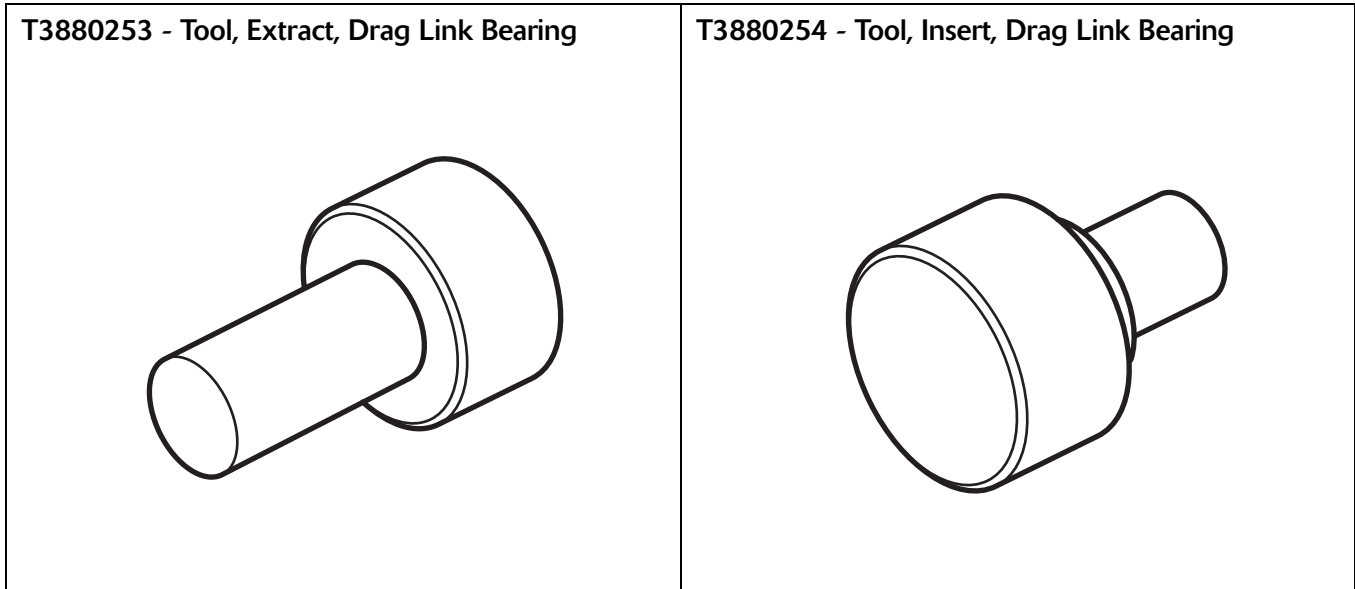

## Other Instructions

Once completed, please mark the service record book that the requirements of this bulletin have been complied with.

## Replacement Procedure

### Note:

- **Replacement of the drag link to drop link bolt, when installed from the right hand side, will require removal of the pannier rails, rear bodywork, exhaust intermediate pipe and silencer.**

Replace the drag link to drop link bolt, nut, bearing sleeve and spacers, and inspect and if necessary replace the drag link rear bearing and seals, following the procedure listed below:

### **Warning**

Throughout the following procedure, ensure that the motorcycle is stabilised and adequately supported to prevent the risk of injury from the motorcycle falling.

### **Warning**

Failure to tighten any of the fasteners to the correct torque specification may result in loss of motorcycle control and an accident.

### **Warning**

If the engine has recently been running, the exhaust system will be hot. Before working on or near the exhaust system, allow sufficient time for the exhaust system to cool as touching any part of a hot exhaust system could cause burn injuries.

## Removal

1. Raise and support the rear of the motorcycle beneath the frame or engine. Position a block to support the rear wheel.
2. Push back the rear edge of the seat and unscrew the exposed fixings. Collect the spacers from beneath the fixings.

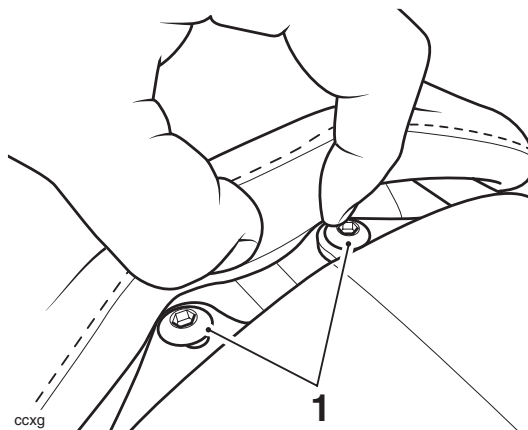

### 1. Seat fasteners

3. To remove the seat, lift the rear of the seat and slide it towards the rear of the motorcycle.
4. Disconnect the battery, negative (black) lead first.
5. Release the four front pannier rail fixings (two on each side). Collect the washers from under the fixings.

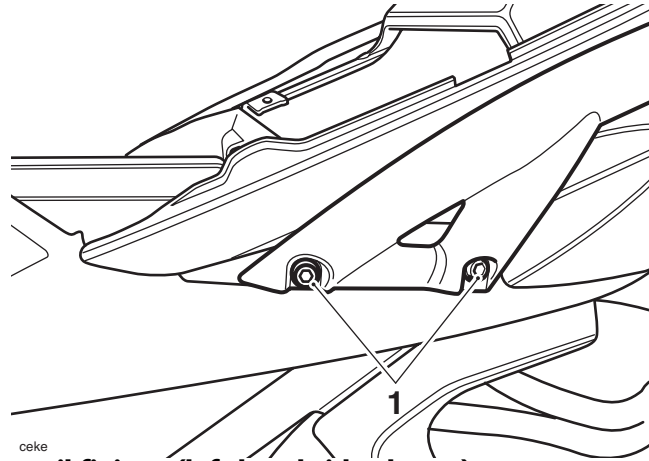

1. Front pannier rail fixings (left hand side shown)

## ! Caution

When removing the pannier rails, ensure that the surfaces of the rear bodywork are protected from damage. Damage to the rear bodywork, and particularly the painted surfaces could result from inadequate care and/or protection during this process.

6. Remove the four grab rail fixings and carefully remove the grab rail and pannier rails as an assembly. Collect the four spacers from under the grab rail.

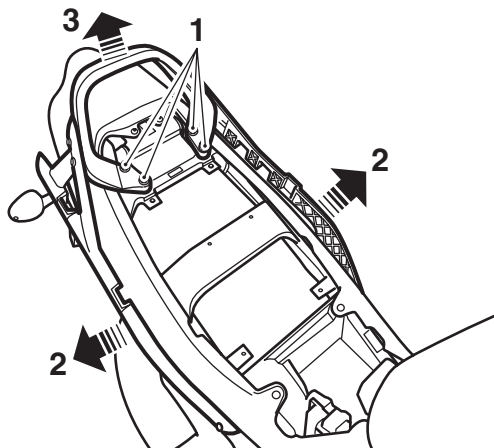

1. Grab rail fixings
2. Pannier rail removal direction
3. Grab rail and pannier rail assembly removal direction

7. Remove the fixings securing the bodywork/side panel to the frame.

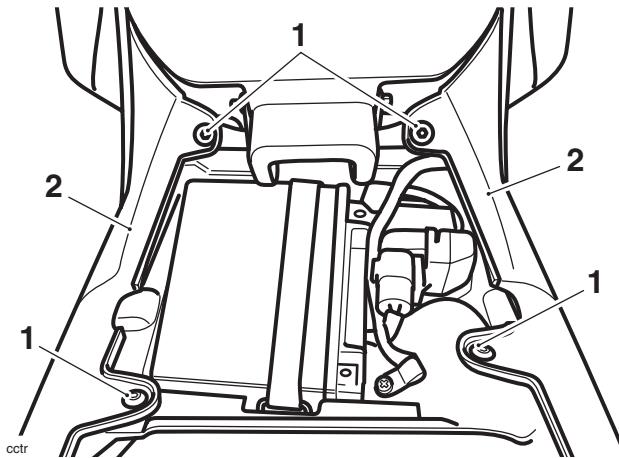

1. Fixings
2. Bodywork/side panel

8. Remove the bodywork/side panel.

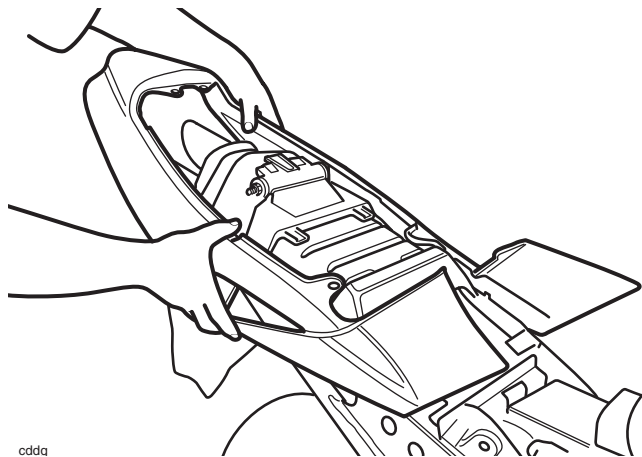

**Bodywork/side Panel Removal**

9. Undo and remove the four fixings securing the rear light unit bracket to the frame. Support the rear light unit/mudguard assembly.

**! Caution**

Do not allow the light unit/mudguard assembly to hang unsupported. Damage to the wiring harness supplying the rear lights may occur if the light unit/mudguard assembly is allowed to hang unsupported.

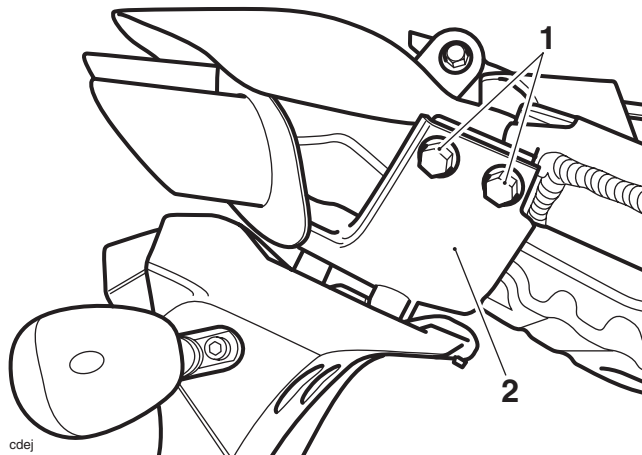

1. Fixings (right hand side shown)
2. Rear light unit bracket

10. Release the clamp securing the silencer to the intermediate pipe.

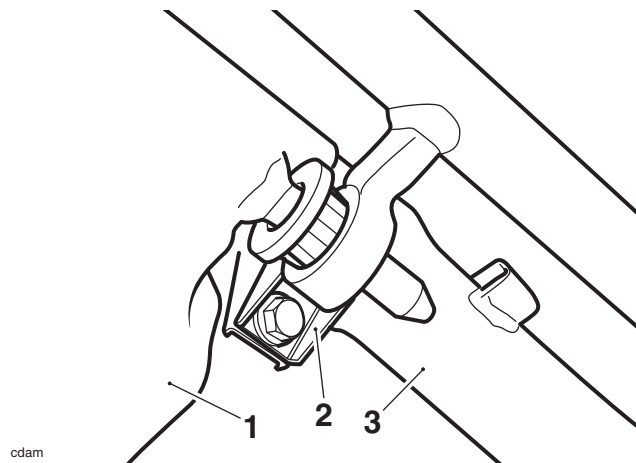

1. Silencer
2. Clamp
3. Intermediate pipe

11. Support the silencer and release the nut and bolt securing the silencer mounting bracket to the rear frame.

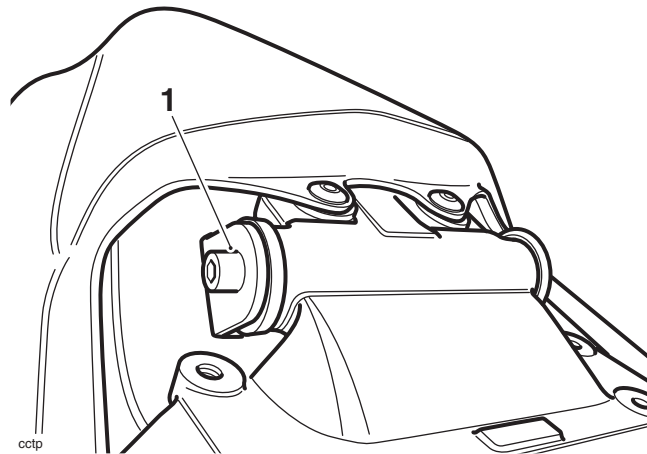

**1. Silencer mounting bracket/fixing**

12. Move the silencer rearwards to disengage its front mountings and remove.



**1. Silencer mounting points**

13. Release the clamp at the downpipe to intermediate pipe joint.

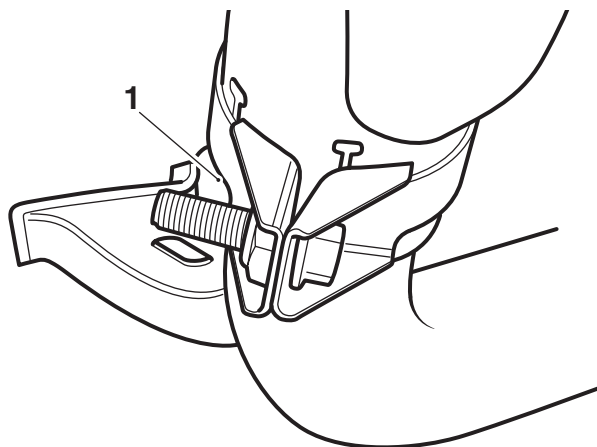

**1. Downpipe to intermediate pipe joint**

14. Release the bolt from the intermediate pipe rear mounting point.

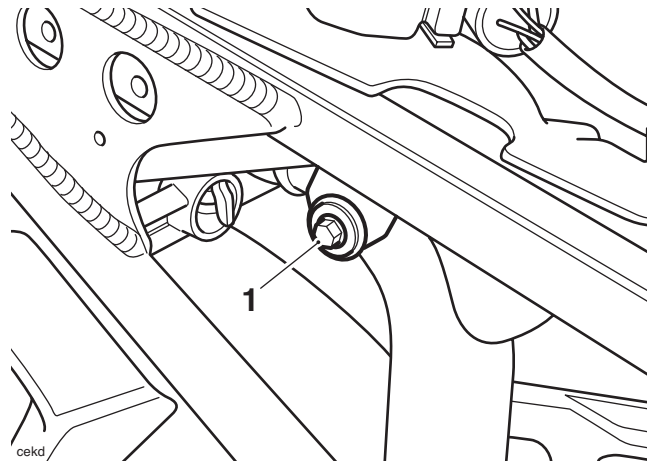

1. Intermediate pipe mounting

15. Remove the intermediate pipe.
16. Remove the nut and bolt securing the drag link to the drop link from the right hand side. Collect the washer from under the bolt head and retain for re-use.

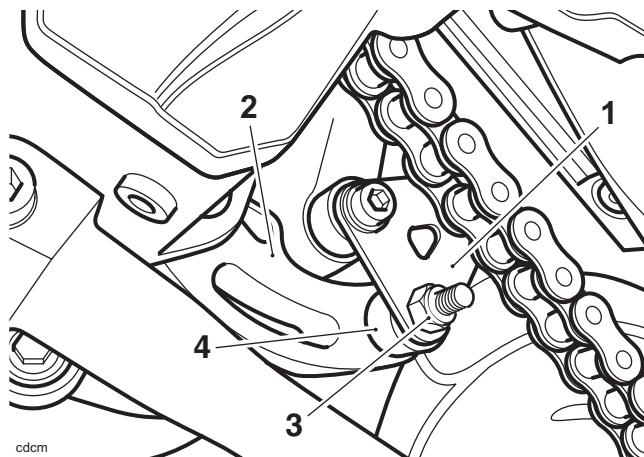

1. Drop link
2. Drag link
3. Drag link to drop link bolt/nut
4. Spacer (left hand shown)

17. Release the drag link from the drop link and collect the spacers.

18. Remove the bearing sleeve from the drag link.

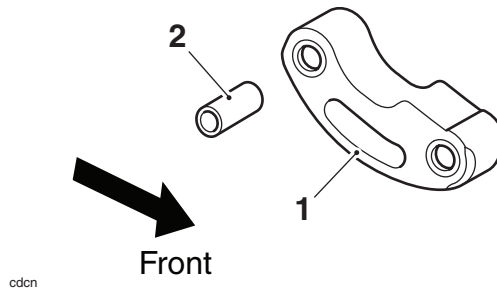

1. Drag link (shown removed from the motorcycle for clarity)
2. Bearing sleeve

19. Discard the nut, bolt, bearing sleeve and spacers, noting the parts return instructions given on page 1.

## Inspection

1. Inspect the bolt for signs of bending. If the bolt is bent, the drag link rear bearing and seals must be replaced.

### Note:

- If the bolt shows no signs of bending, the drag link rear bearing or seals **DO NOT** need to be replaced. However the bolt, bearing sleeve, spacers and nut **MUST** be replaced in all cases, even if they appear to be in good condition.

## Bearing Replacement (only if required)

1. Remove the drag link as follows:
  - Remove the bolt and nut (discard the nut) securing the drag link to the frame.
  - Detach the drag link from the frame.
2. Remove the two rear drag link seals.

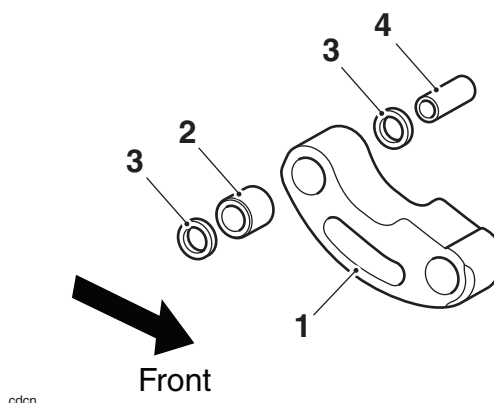

1. Drag link
2. Rear bearing
3. Seals
4. Bearing sleeve

## **Warning**

When using a press, always wear overalls, eye, face and hand protection. Objects such as bearings frequently break-up under load and the debris caused during break-up may cause damage and injury to unprotected parts of the body.

Never wear loose clothing which could become trapped in the press and cause a crushing injury to the hand, arms or other parts of the anatomy.

3. Transfer the drag link to a press, and using service tool T3880253, press out the rear bearing through the drag link as shown below. Collect the bearing as it is released, and remove the tool from the drag link.

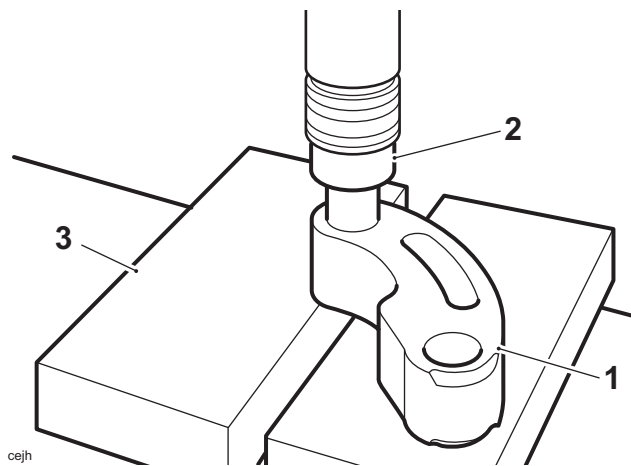

1. Drag link
2. Tool T3880253
3. Press bars

## **Caution**

The bearing must be installed with the marked side of the bearing facing towards service tool T3880254. Failure to follow this instruction will result in damage to the bearing.

4. Position the new bearing to service tool T3880254, with the marked side of the bearing facing towards the tool.

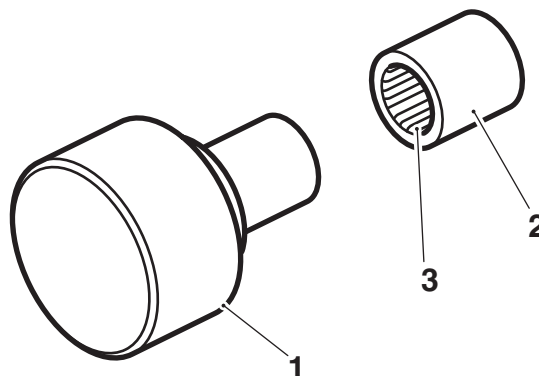

1. Tool T3880254
2. Bearing (shown with marked side facing the service tool)
3. Bearing markings

**Warning**

When using a press, always wear overalls, eye, face and hand protection. Objects such as bearings frequently break-up under load and the debris caused during break-up may cause damage and injury to unprotected parts of the body.

Never wear loose clothing which could become trapped in the press and cause a crushing injury to the hand, arms or other parts of the anatomy.

5. Position the service tool and bearing to the press as shown below, and press in the new bearing until the tool contacts the drag link.

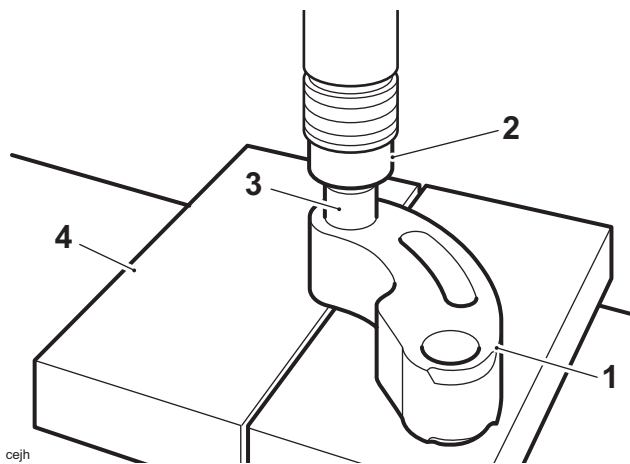

1. Drag link
2. Tool T3880254
3. Bearing
4. Press bars

6. Install two new seals, with the marked side of the seal facing outwards, until they are flush with the surface of the drag link.

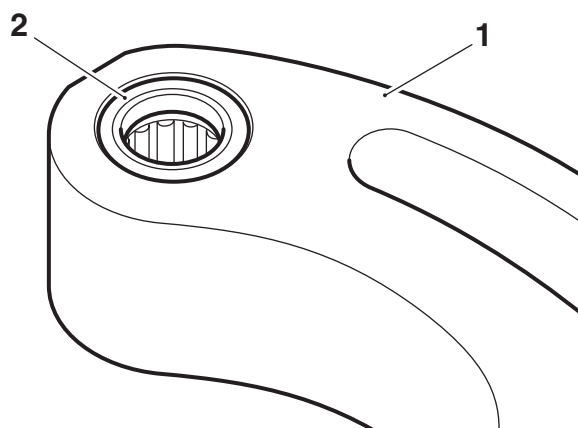

1. Drag link
2. Seal (flush with surface of drag link)

**Note:**

- **This bulletin does not include replacement of the front drag link bearing, seals or bearing sleeve. Replacement of these items, if required, must be treated as a separate repair item, and claimed using a separate warranty claim.**
7. Remove the front bearing sleeve and inspect the front bearing and seals for damage or wear. Replace any damaged or worn components. Lubricate the front bearing and seals with grease to NLGI 2 specification (we recommend Mobil grease HP222). Clean and refit the bearing sleeve.

**Drag link Installation (only if the bearing or seals have been replaced)**

1. Position the drag link in the correct orientation to the frame and refit the original front bolt. Fit a new nut (part number T3350005) and tighten to **48 Nm**.

**Assembly**

1. Lubricate the rear bearing with grease to NLGI 2 specification (we recommend Mobil grease HP222).
2. Lubricate the rear seal's knife-edges with grease to NLGI 2 specification (we recommend Mobil grease HP222).
3. Install the new, longer bearing sleeve (part number T2050102) to the drag link, ensuring it protrudes evenly through either side of the drag link.

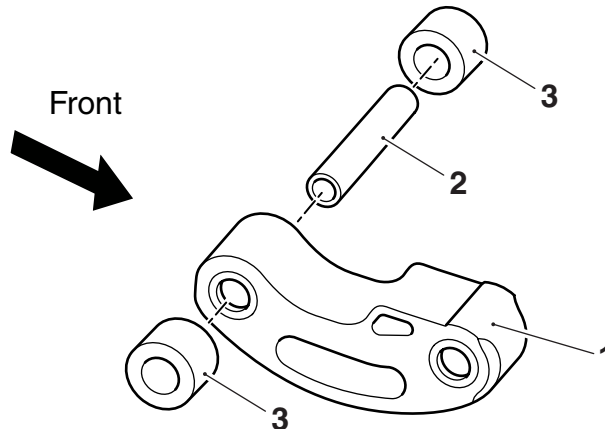

1. **Drag link (shown with the bearing and seals assembled)**
  2. **Bearing sleeve**
  3. **Spacers**
4. Lubricate the exposed outer surface of the bearing sleeve with grease to NLGI 2 specification (we recommend Mobil grease HP222).

5. Fit the two spacers (part number T2050103) to the outside of the bearing sleeve (one on each side) as shown below.

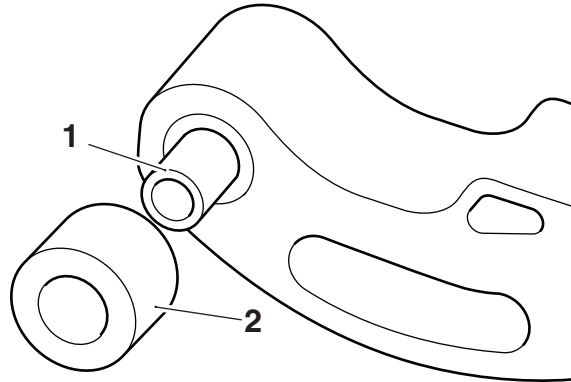

**1. New bearing sleeve**

**2. Spacer**

6. Align the drag link to the drop link and fit a hardened washer to each end of the bearing sleeve, between the side plates of the drop link.

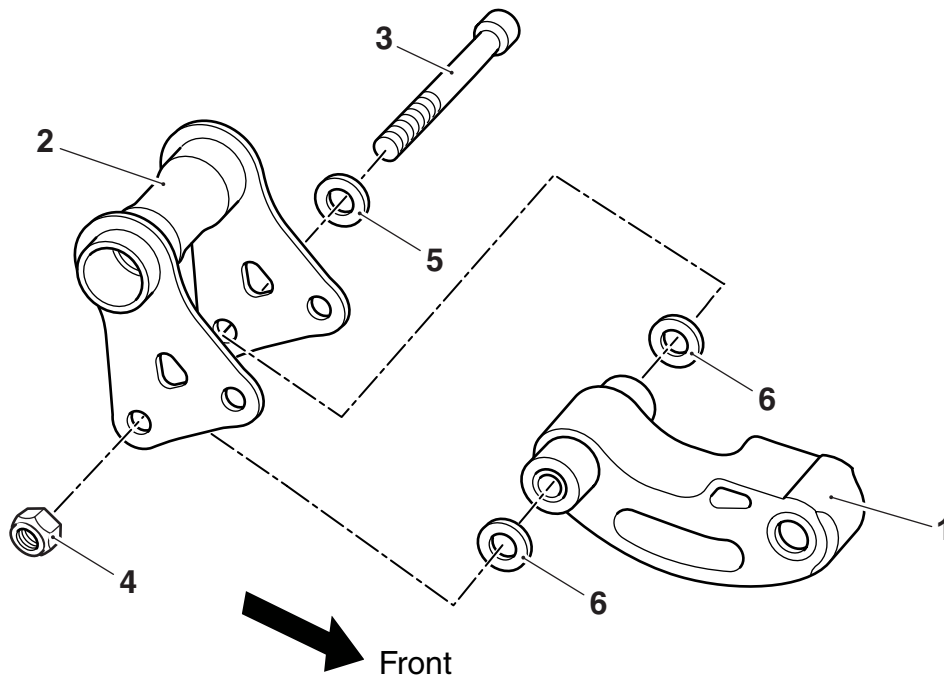

**1. Drag link (shown with the bearing sleeve and spacers assembled)**

**2. Drop link**

**3. Drag link to drop link bolt**

**4. Nut**

**5. Hardened washer (removed from original bolt)**

**6. New hardened washers**

7. Fit the hardened washer (removed from the original bolt) to the new bolt (part number T3330335).

8. Install the new drag link to drop link bolt (part number T3330335) from the left hand side, fit a new nut (part number T3350005) and tighten to **48 Nm**.

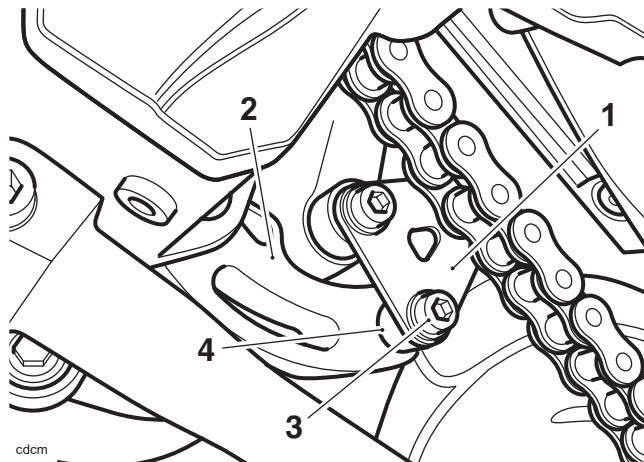

1. Drop link
2. Drag link
3. Drag link to drop link bolt
4. Spacer (left hand shown)

9. Refit the intermediate pipe to the downpipe.
10. Align the intermediate pipe upper fixing and tighten to **15 Nm**.

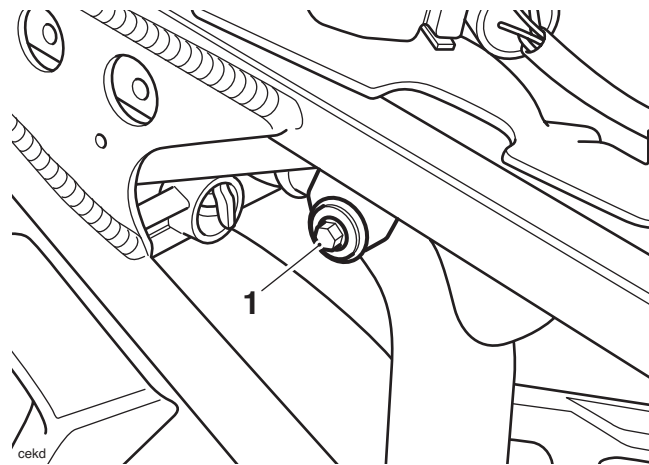

1. Intermediate pipe mounting

11. Orientate the lower intermediate pipe clamp such that, when tightened, its fixing will not foul the rear suspension linkage (when at full travel or any other point). Tighten to **15 Nm**.

12. Position and engage the silencer to its front mountings.



**1. Silencer mounting points**

13. Position and engage the silencer to the intermediate pipe.
14. Align the silencer mounting brackets to the frame. Refit the nut and bolt and tighten to **15 Nm**.

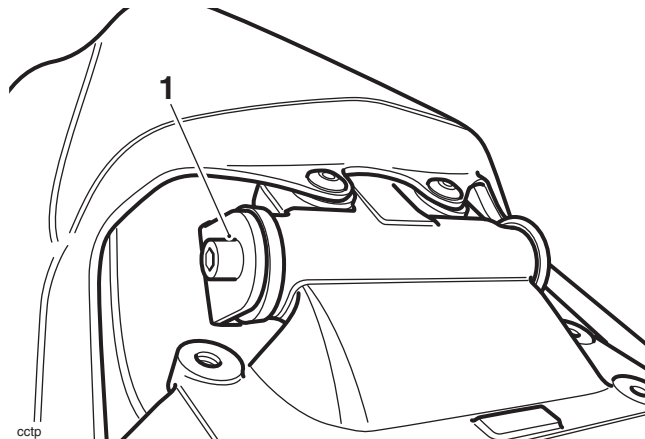

**1. Silencer mounting bolt**

15. Align the silencer to intermediate pipe joint clamp, ensuring that it is oriented in the position shown and that the tabs in the clamp locate to the correct slots cut in the secondary pipe. Tighten the clamp to **15 Nm**.

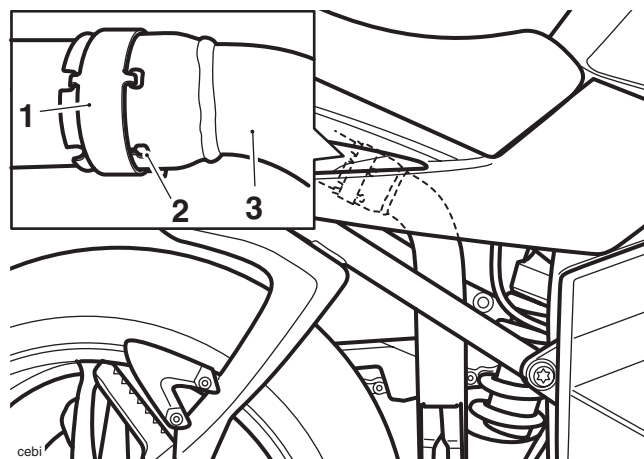

- 1. Exhaust pipe clamp**  
**2. Tabs and slot**  
**3. Intermediate exhaust pipe**

16. Align the rear light unit bracket to the frame. Secure the rear light unit bracket with the four fixings and tighten to **18 Nm**.

**! Caution**

Do not allow the light unit/mudguard assembly to hang unsupported. Damage to the wiring harness supplying the rear lights may occur if the light unit/mudguard assembly is allowed to hang unsupported.

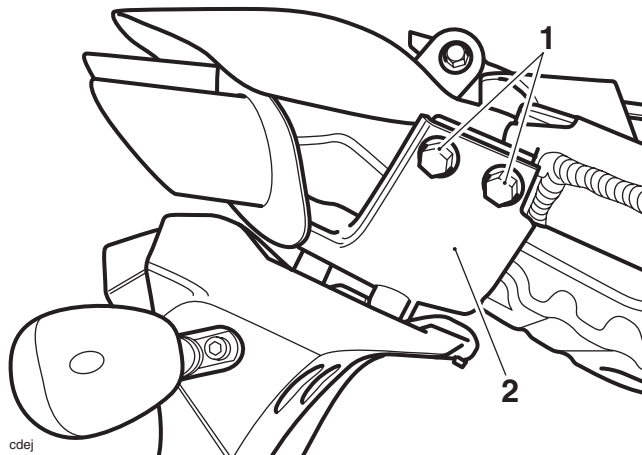

1. Fixings (right hand side shown)
2. Rear light unit bracket

17. Align the bodywork/side panel to the frame.

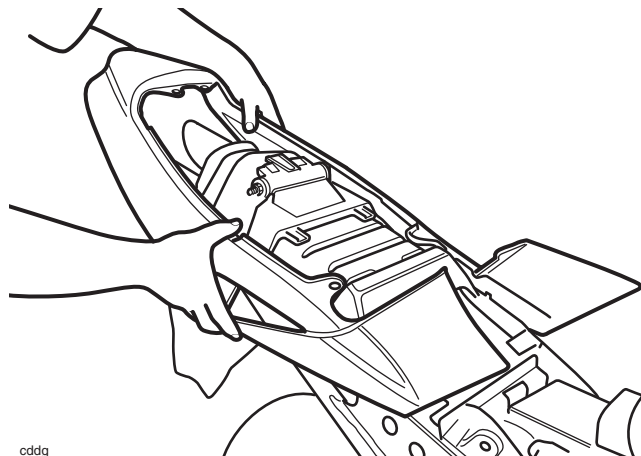

**Bodywork/side Panel Removal**

18. Refit the fixings securing the bodywork/side panel to the frame. Tighten to **3 Nm**.

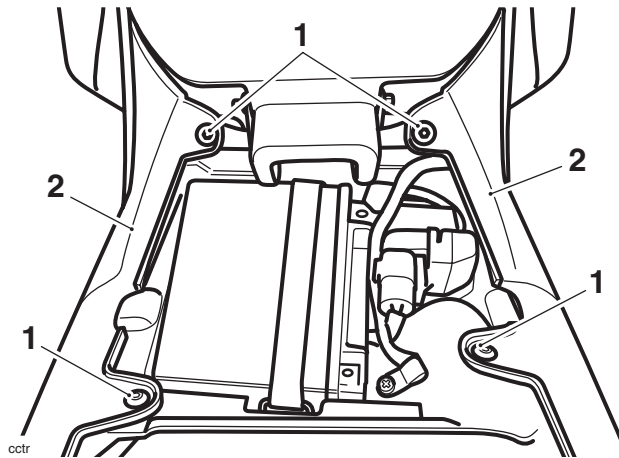

- 1. Fixings
- 2. Bodywork/side panel

**! Caution**

When removing the pannier rails, ensure that the surfaces of the rear bodywork are protected from damage. Damage to the rear bodywork, and particularly the painted surfaces could result from inadequate care and/or protection during this process.

19. Carefully refit the grab rail and pannier rails, ensuring the four spacers are installed under the grab rail.

20. Refit the four grab rail fixings. Tighten to **27 Nm**.

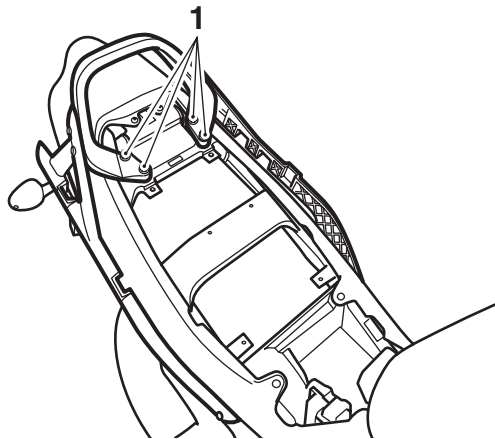

- 1. Grab rail fixings

21. Refit the four pannier rail front capscrews and washers. Tighten to **9 Nm**.

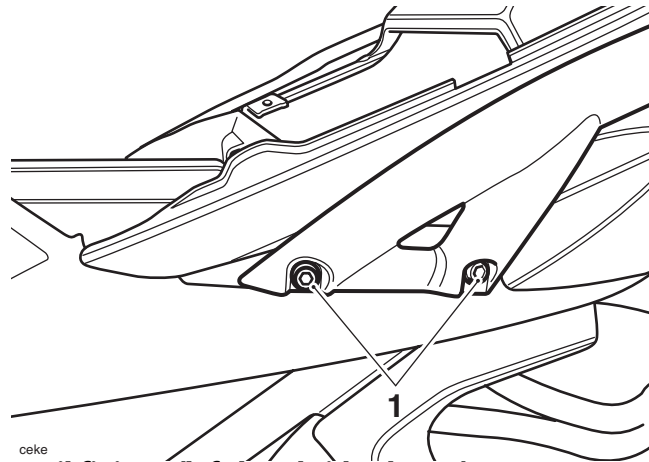

**1. Front pannier rail fixings (left hand side shown)**

22. Connect the battery, positive (red) lead first.

23. Position the seat to the motorcycle.

24. Push back the rear edge of the seat and refit the seat fixings. Tighten to **3 Nm**.

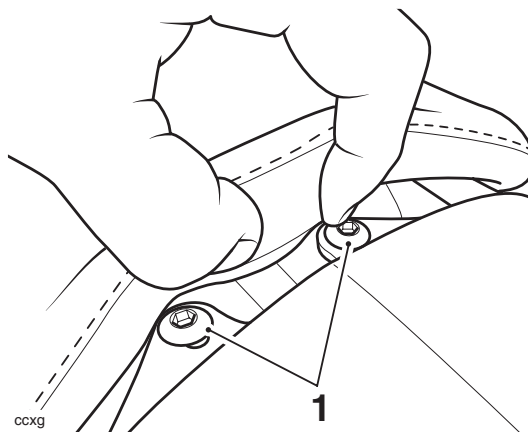

**1. Seat fasteners**

25. Lower the motorcycle to the ground and remove the support.

## Circulation

(Initial and date when read and return to central file holder)

| Service Manager | Parts Manager | Sales Manager | Workshop Supervisor | Technician 1 | Technician 2 |
|-----------------|---------------|---------------|---------------------|--------------|--------------|
|                 |               |               |                     |              |              |