



RECALL CAMPAIGN BULLETIN

Reference:

NTB07-009

Date:

February 16, 2007

VOLUNTARY RECALL CAMPAIGN 2004 – 2006 TITAN REAR DOOR HARNESS

CAMPAIGN I.D. # R0616
 NHTSA #: 06V-459
 APPLIED VEHICLES: 2004 – 2006 Titan (A60) King Cab only
 APPLIED VINs: 2004: 1N6*A06A*4N 500006 - 593463
 1N6*A06B*4N 500000 - 593471
 2005: 1N6*A06A*5N 500002 - 580219
 1N6*A06B*5N 500007 - 580226
 2006: 1N6*A06A*6N 500003 - 576810
 1N6*A06B*6N 500000 - 576805

NOTE: Use Service Comm to determine campaign eligibility.

INTRODUCTION

Nissan has determined that on some 2004 – 2006 model year Titan King Cab vehicles, a defect that relates to motor vehicle safety exists.

In some affected vehicles, there is the possibility that the wires in the harness routed through the rear doors and into the body on each side of the vehicle **may** break due to over bending of the harness as the doors are opened and closed. The wires in the harness control various systems including the seat belt pretensioners, the passenger side seat belt tension sensor, and rear audio speakers.

If the wire for the seat belt pretensioners breaks and makes contact with a wire for the speaker, there is a possibility that the pretensioner may deploy and tighten the seat belt. If this happens when the belt is retracted, it will not be possible to use the seat belt. If one of the wires for the seat belt tension sensor breaks inside the passenger side harness, the passenger side front air bag will not deploy as designed in a frontal crash. Nissan is conducting a Voluntary Recall Campaign to inspect the wire harness cover for damage and, if necessary, a new wiring harness with a new type cover will be installed and rerouted.

IDENTIFICATION NUMBER

Nissan has assigned identification number R0616 to this campaign. This number must appear on all communications and documentation of any nature dealing with this campaign.

NUMBER OF VEHICLES POTENTIALLY AFFECTED

The number of vehicles potentially affected is approximately 96,500

DEALER RESPONSIBILITY

It is the dealers responsibility to check Service Comm for the campaign status on each vehicle falling within the range of this voluntary safety recall which for any reason enters the service department. This includes vehicles purchased from private parties or presented by transient (tourist) owners and vehicles in a dealer's inventory. Federal law requires that new vehicles in dealer inventory which are the subject of a safety recall must be corrected prior to sale. Failure to do so can result in civil penalties by the National Highway Traffic Safety Administration. While federal law applies only to new vehicles, Nissan strongly encourages dealers to correct any used vehicles in their inventory before they are retailed.

TABLE OF CONTENTS

REQUIRED SPECIAL TOOLS.....	Page 3
REPAIR OVERVIEW	4
SERVICE PROCEDURE	5
Inspection Procedure 1: Seat Belt Retractors	5
Inspection Procedure 2: Air Bag Light / Codes	5
Inspection Procedure 3: Harness Damage.....	6
Install Update Kit: Replace Vinyl Tube with Corrugated Tube.....	7
Harness Replacement: Includes seat belt replacement, if needed.	14
Floor and Rear Door: Left and/or right side	14
Rear Cabin Wall Harness Branch: Left side only.....	34
High Mount Stop Lamp Harness Branch: Right side only.....	37
Side Curtain Air Bag Harness Branch: Right side only.....	43
PARTS INFORMATION	48
CLAIMS INFORMATION	49
OWNER'S LETTERS	50

REQUIRED SPECIAL TOOLS

- Each dealer was shipped one pair of Vinyl Tube Scissors.
- Use these scissors when removing the wiring harness vinyl tubing during the installation of the Update Kit.

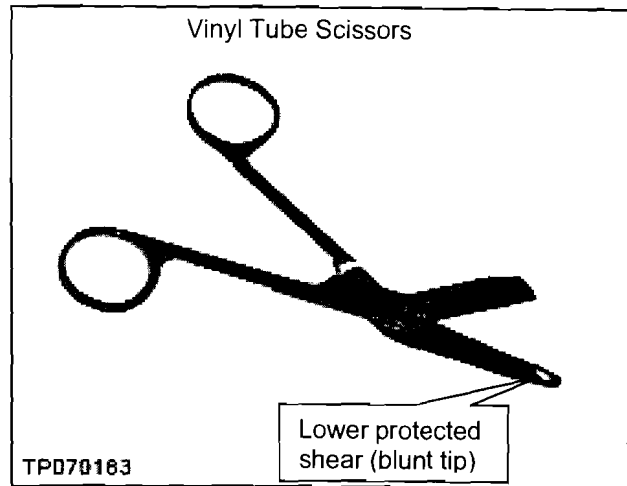

CAUTION: It is very important that you use the Vinyl Tube Scissors when removing the wiring harness vinyl tubing. Failure to use the Vinyl Tube Scissors for this procedure could cause damage to the electrical wiring and may affect vehicle electrical system functions.

- Replacement or additional Vinyl Tube Scissors can be ordered by completing and faxing the special tool order form which is available on NNA.net.com under My Documents in the Parts/Campaign and Service/Campaign categories.

NOTE:

- If replacement of a wiring harness is required, many trim and finisher parts will be removed.
- Plastic "Trim Tool Set" J-46534 (an "essential tool") should be used when removing trim and finisher parts. This tool is available from TECH-MATE at 1-800-662-2001.

REPAIR OVERVIEW

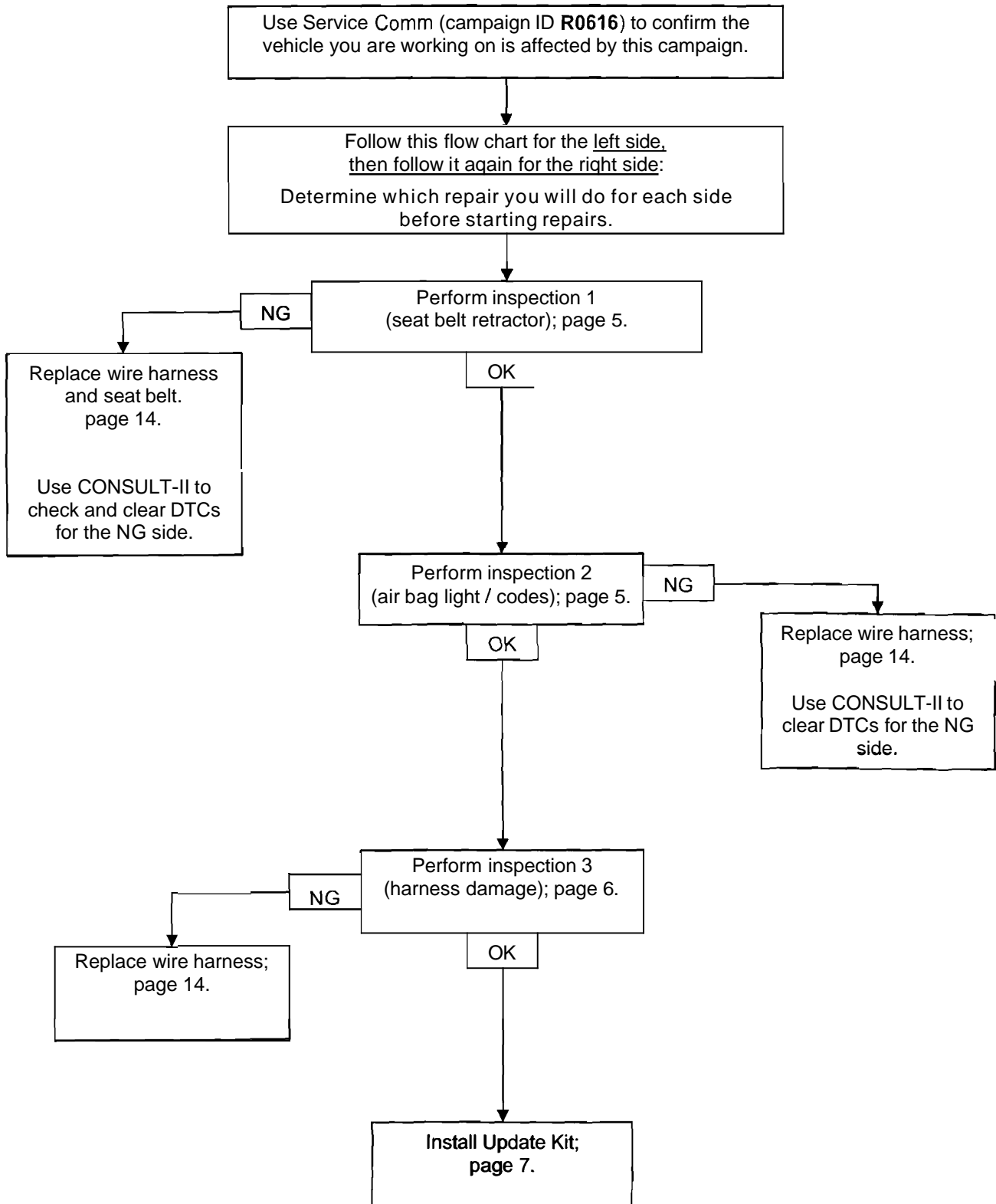

SERVICE PROCEDURE

Inspection Procedure 1 (Front **Seatbelt** Retractors)

1. Extend (pull out) the front seat belt, and then let it retract (pull back).
2. Confirm the seat belt extends and retracts.

NG: Replace the seat belt and wire harness for that side.

OK: Go to Inspection Procedure 2.

Inspection procedure 2 (Air Bag Warning Light ■ Codes Stored)

1. Turn the ignition ON and observe the air bag warning light:

Light comes on for 7 seconds and then goes out: OK, go to Inspection Procedure 3 (next page).

- Light stays ON or blinks: NG, go to next step (step 2).
- Light does not come on at all: The warning light is not working correctly. This condition is not covered by this campaign. Use the Service Manual and standard warranty procedures to repair the warning light before proceeding.

2. Connect CONSULT-11 to the vehicle and retrieve DTCs

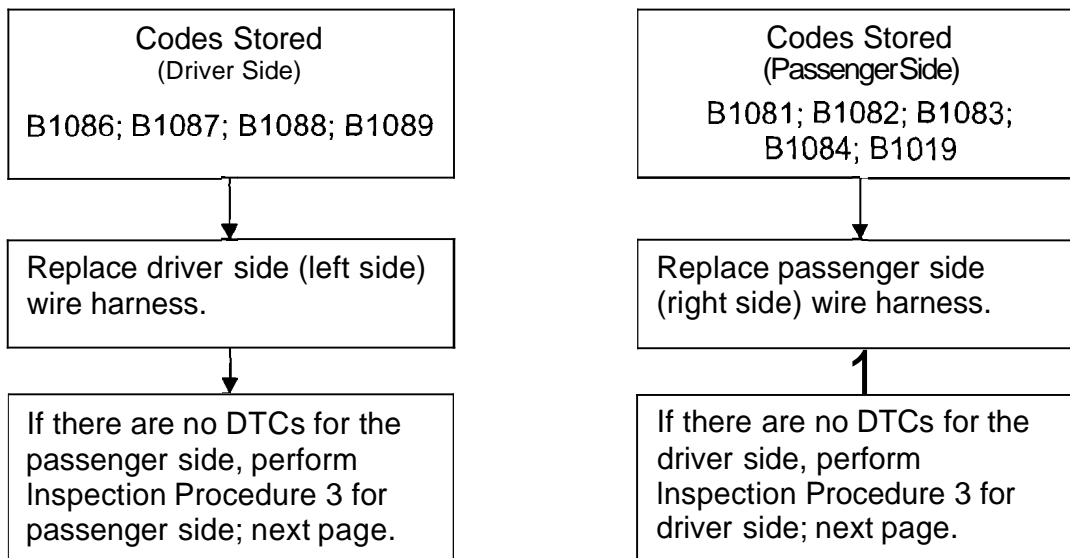

Inspection Procedure 3 (Inspect Wire Harness at Rear Door Hinge)

1. Open the rear door and locate the harness in the door hinge area.

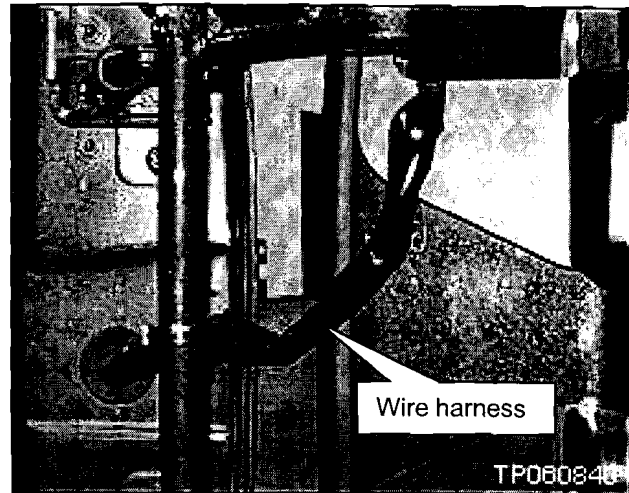

Figure A1

2. Inspect the wire harness vinyl tube:
 - Inspect the entire visible area.
 - Look for worn areas, tears, and/or slits

In both of these examples, the opening is larger than 2 mm (NG)

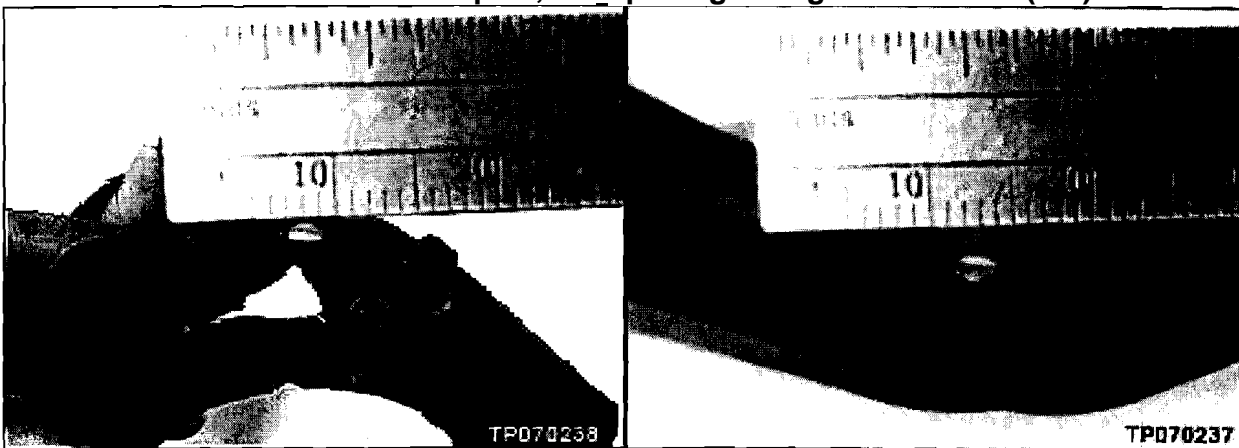

Figure A2

3. Any areas where you can see the wires inside the vinyl tube, measure the size of the opening.
 - OK; no opening in the vinyl tube or opening is 2 mm or smaller; replace the vinyl tube with the corrugated tube – Update Kit (see page 7).
 - NG; opening in the vinyl tube is larger than 2 mm: Replace the wire harness (see page 14).

Update Kit Installation (Replace Vinyl Tube with Corrugated Tube)

1. Remove the body clip from the body (see Figure B1).
2. Remove the hinge rod clip from the hinge rod (see Figure B1).
3. Cut both clips off of the harness.

NOTE: These clips will not be reused.

4. Remove the tape that is holding the door grommet to the vinyl tube (see Figure B1).

IMPORTANT: Do not use a cutting tool to remove the tape. Remove it by hand so you won't damage the door grommet.

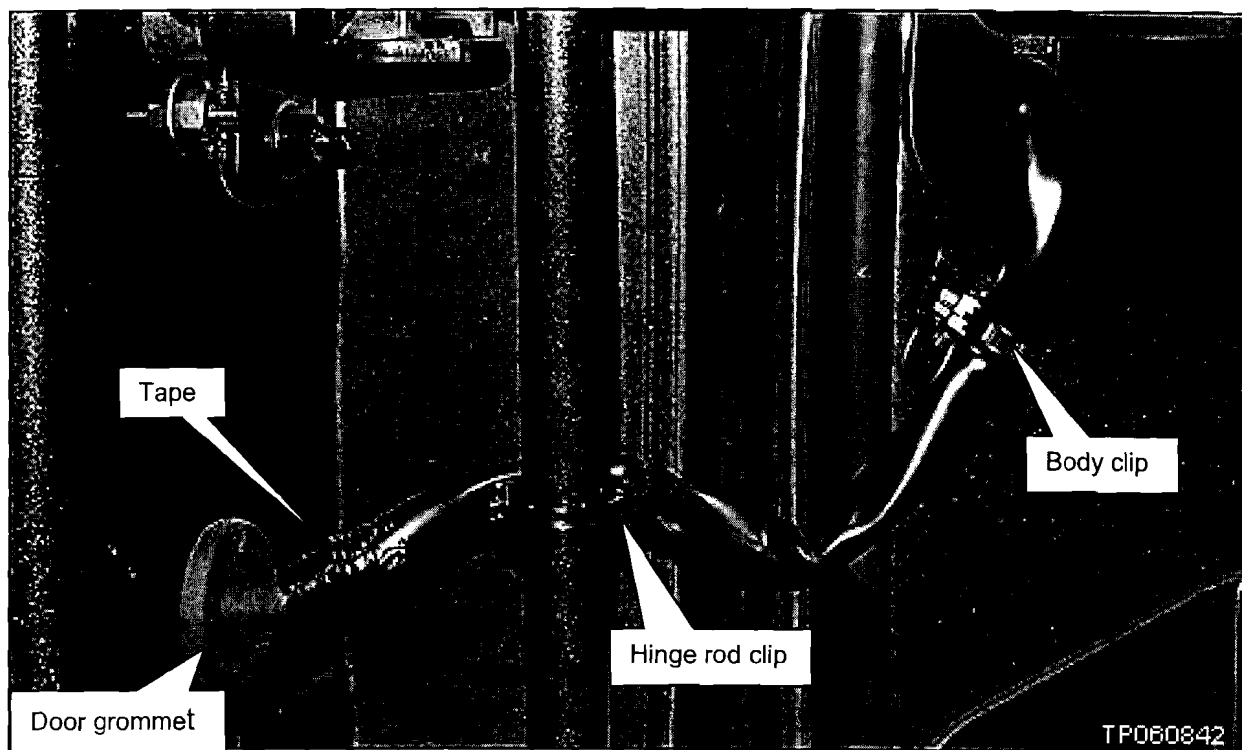

5. Mark the harness vinyl tube 10 mm above the spot where the body harness clip was located (see Figure 62).
6. Mark the harness vinyl tube 15 mm from the door grommet (see Figure 62)

IMPORTANT:

- Make sure you have marked the vinyl tube correctly.
- You will be removing the vinyl tube between the marks that you just made.
- It is very important that you remove only the amount of vinyl tube between the marks.

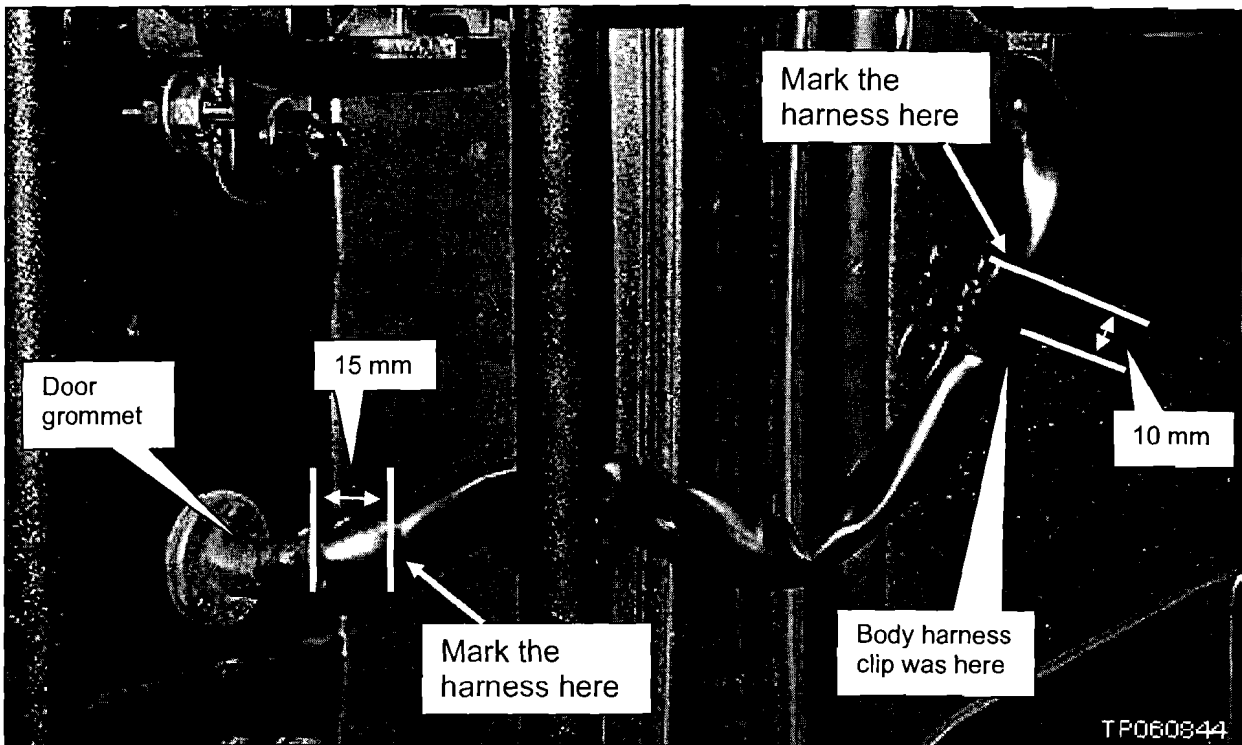

Figure B2

Using the Vinyl Tube Scissors, **carefully** cut off the vinyl tube between the marks you made in steps 5 and 6.

IMPORTANT:

- **DO NOT** use a razorblade.
- Keep the lower (protected — blunt end) shear of the scissors towards the wires inside the vinyl tube.
- Don't damage the wires inside the vinyl tube.

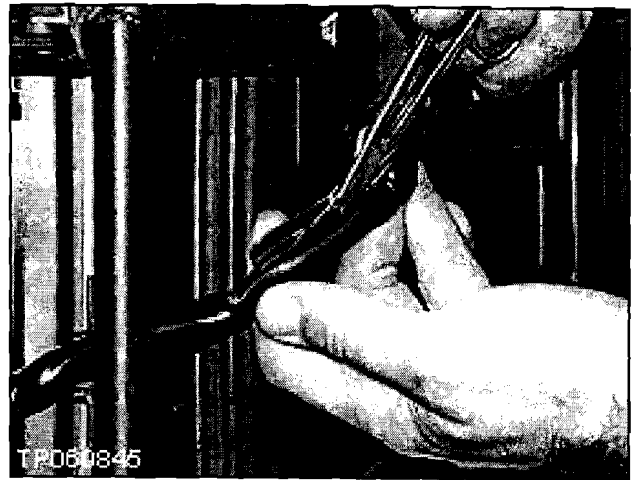

Figure B3

CAUTION: It is very important that you use the Vinyl Tube Scissors when removing the wiring harness vinyl tubing. Failure to use the Vinyl Tube Scissors for this procedure could cause damage to the electrical wiring and may affect vehicle electrical system functions.

8. Once the vinyl tube is cut off, put vinyl tape on the harness in two spots as shown in Figure B4.

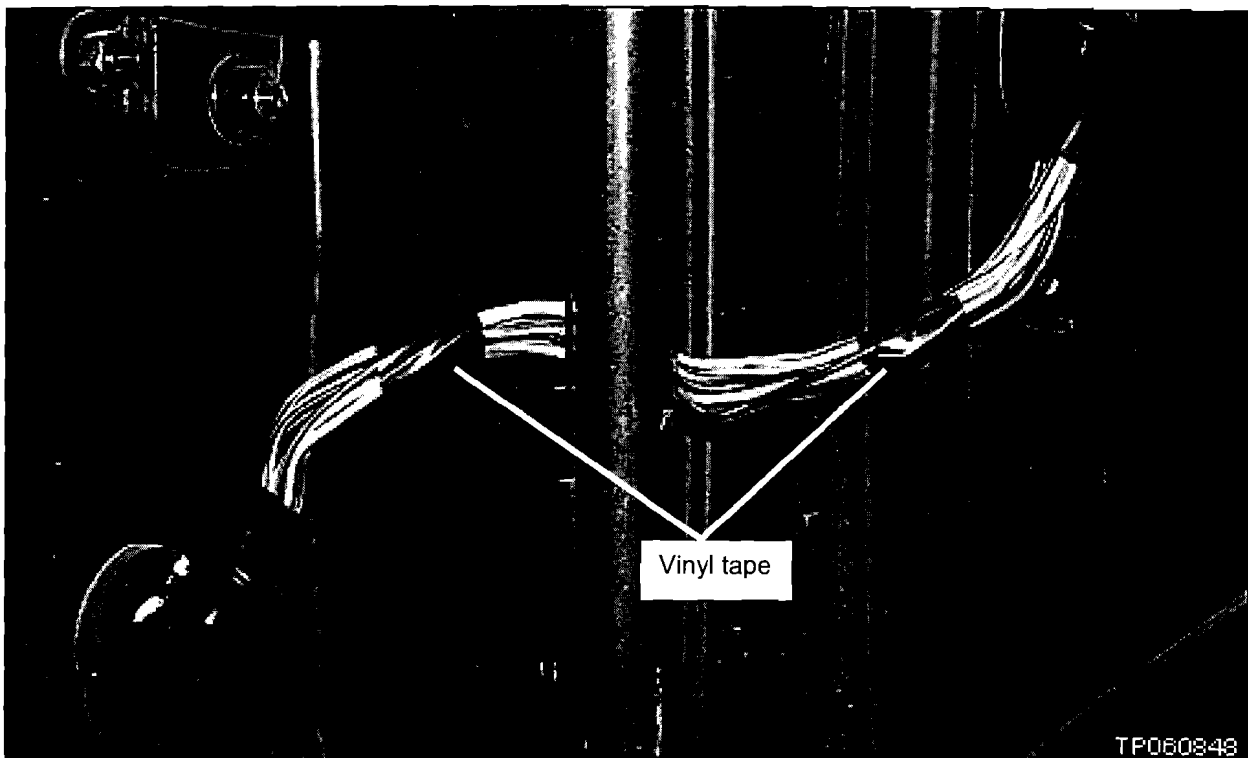

Figure B4

9. Install the corrugated tube over the harness.

The corrugated tube will replace the vinyl tube that you cut off.

- Install the corrugated tube in the direction shown in Figure B5.

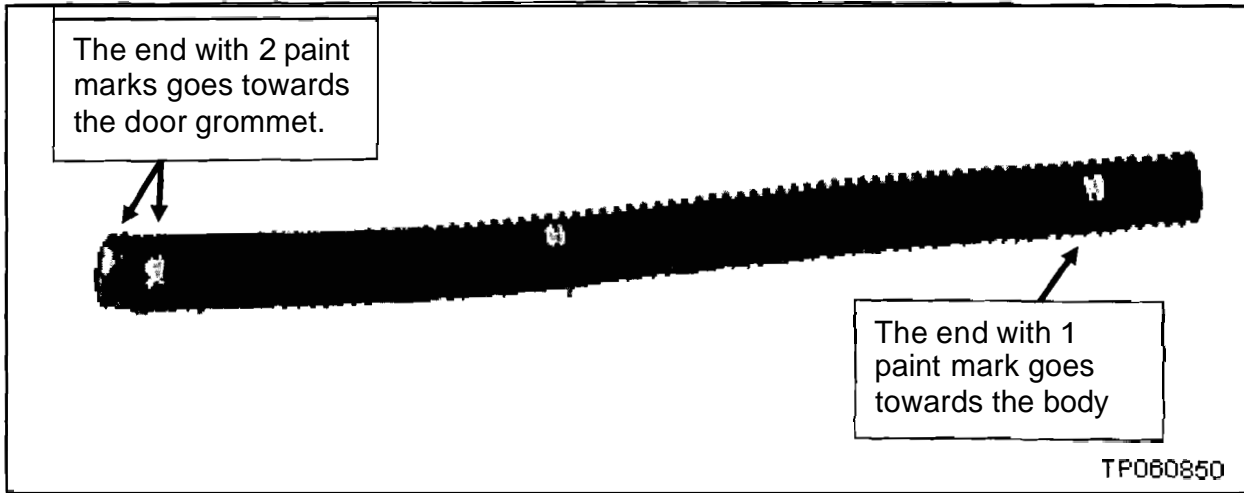

Figure B5

- Slide the corrugated tube inside the door grommet about 10 mm. The second paint mark should just be visible (see Figure B6). You may need to roll the grommet back and then forward over the tube.
- At the body end, the corrugated tube should meet the vinyl tube with no gap.
- The paint marks must be facing away from the door/body as shown in Figure B6.

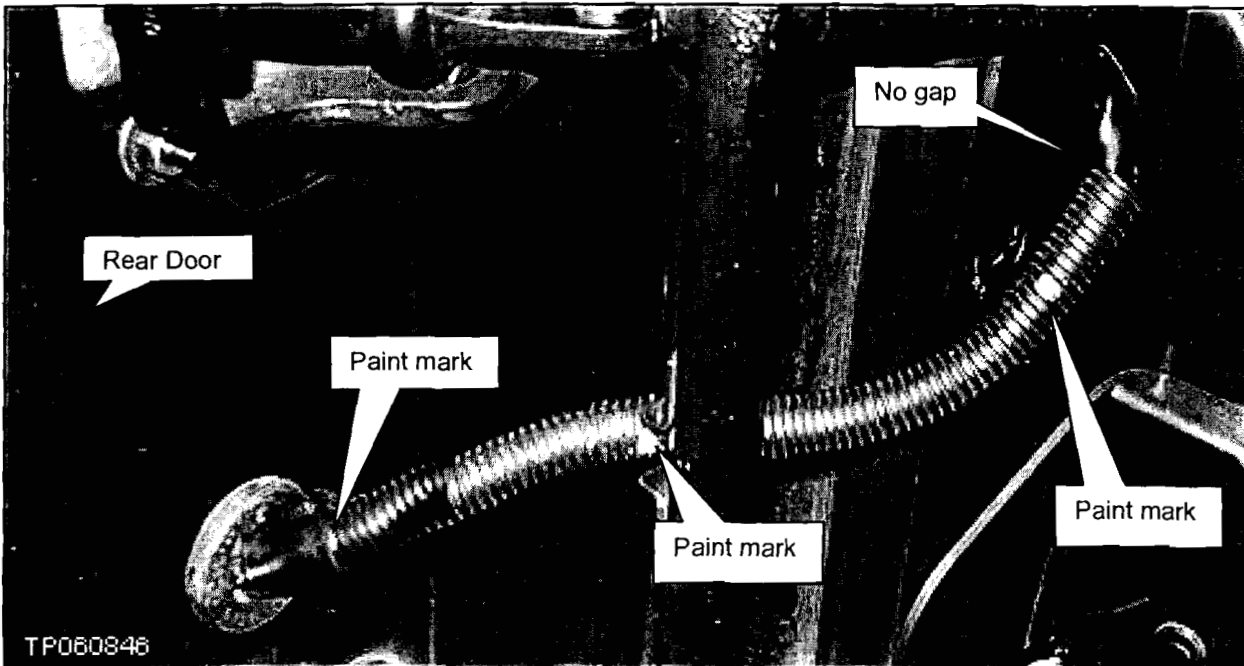

Figure B6

10. Install the new body clip over the paint mark on the body-side (see Figure B7).

- Feed the strap through the buckle so the strap is UP as shown in Figure B7.

11. Install the new hinge rod clip over the center paint mark (see Figure B7).

- Feed the strap through the buckle so the strap is UP as shown in Figure B7.

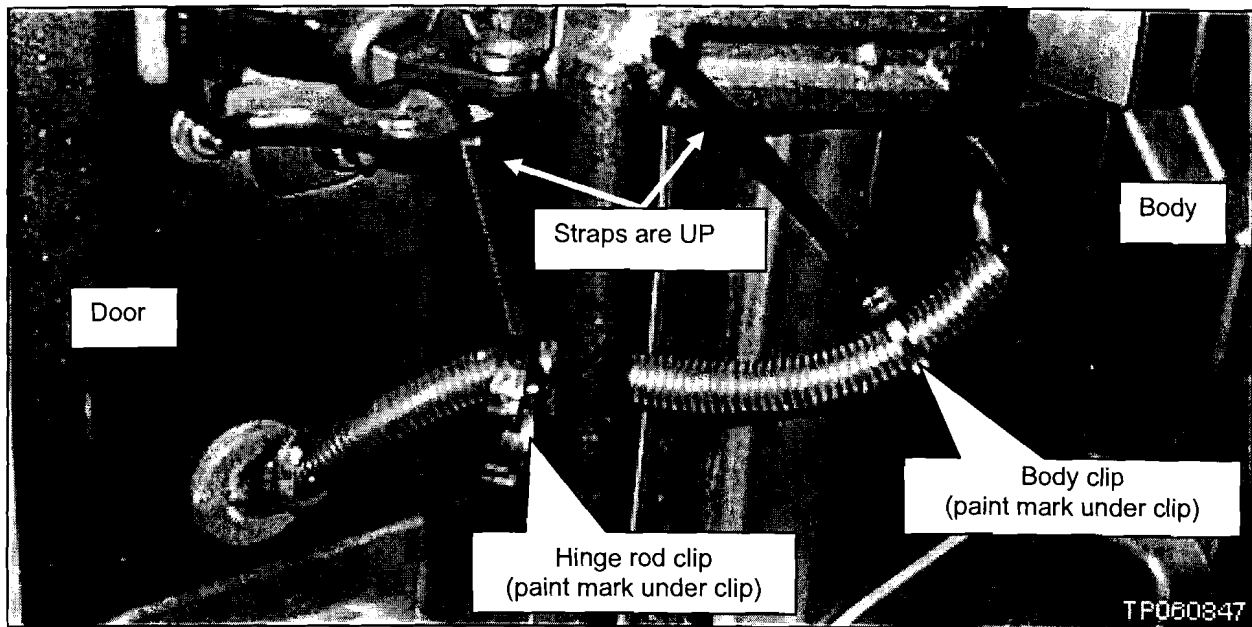

Figure B7

12. Cut off the excess strap. Leave only 3 to 6 mm (1/8 to 1/4 inch).

13. First, tape the door grommet to the corrugated tube, then

14. Wrap the entire length of the corrugated tube with vinyl tape.

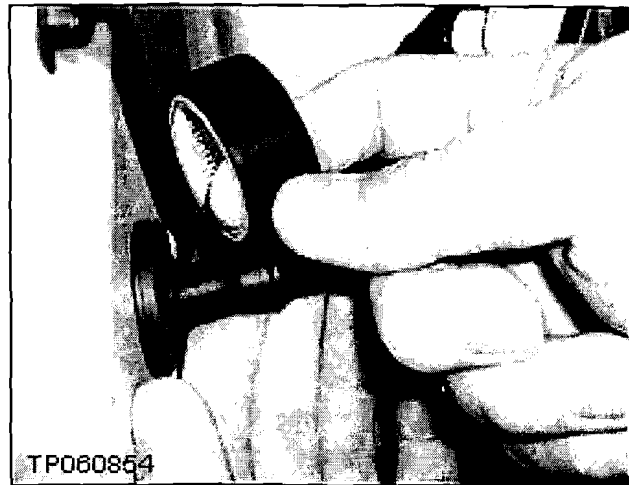

Figure B8

- As you wrap, keep the tape tight and the tape roll close to the harness.
- Over-lap the tape 50% as you wrap.
- Make sure to wrap around the clips (diaper wrap) so they will not move—the clips must stay in position.
- Make sure to cover the area on the body side between the corrugated tube and the vinyl tube.
- Double wrap the entire length; one layer left to right and another layer right to left.

15. Attach the new hinge rod clip below the bracket as shown in Figure B9.

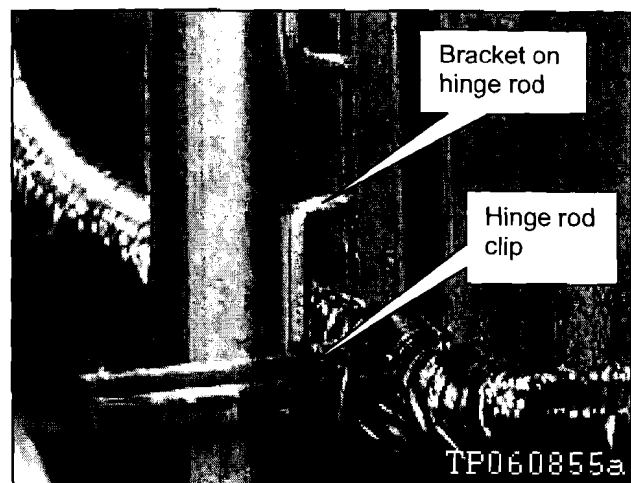

Figure B9

16. Attach the new body clip to the body.

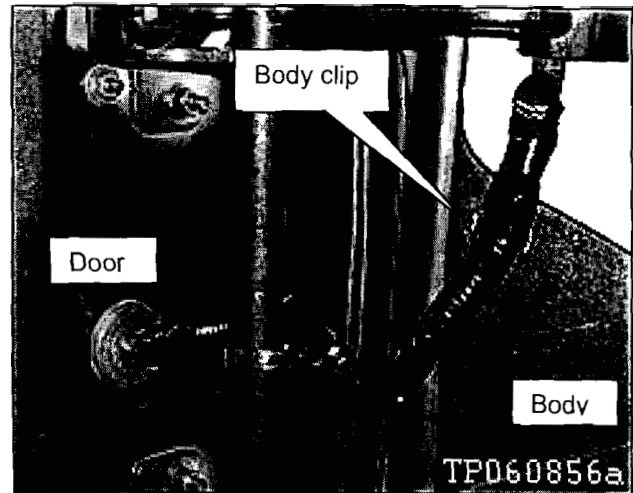

Figure B10

Final Quality Check

17. Check the air bag light operation as follows:

- a. Turn the ignition ON.
- b. Look at the air bag light.
- c. Make sure the air bag warning light comes on for 7 seconds and then goes out.

Harness Replacement (includes seat belt replacement, if needed)

NOTE:

- There are several model variations (power seats, audio, side air bag, navigation, etc). Due to these variations the harness removal photos in this procedure may not have the exact interior trim, connectors, and harness mounting locations as the vehicle you are working on.
- It is recommended that you mark the harness mounting location during disassembly.

Floor and Rear Door (Left and/or Right Side)

- This portion of the procedure is for the sections of the harness that are on the floor of the vehicle (under the carpet) and inside the rear door.
- The photos in this portion of the procedure are of the left side (driver side). If you are working on the right side (passenger side) the photos are a mirror image.

1. Write down the radio station presets.

Presets	1	2	3	4	5	6
A						
B						
C						

2. If equipped with power seats; move the seats to the "mid-point" position (half-way between full forward and full rearward).
3. Put the gear selector in the Neutral position.
4. Disconnect both battery cables —negative cable first.

5. Remove the front seat.

- a. Remove the 4 seat mounting bolts.
- b. Disconnect all of the seat electrical connectors.
- c. Remove the seat from the vehicle and place it in a clean area.

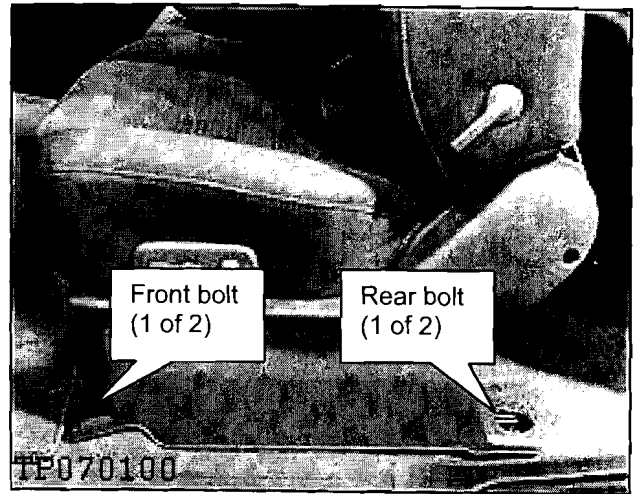

Figure C1

6. If equipped; remove sub woofer or navigation control unit.

Sub Woofer—under driver's seat

- a. Disconnect the electrical connector.
- b. Remove the 3 mounting bolts.
- c. Remove the sub-woofer from the vehicle.

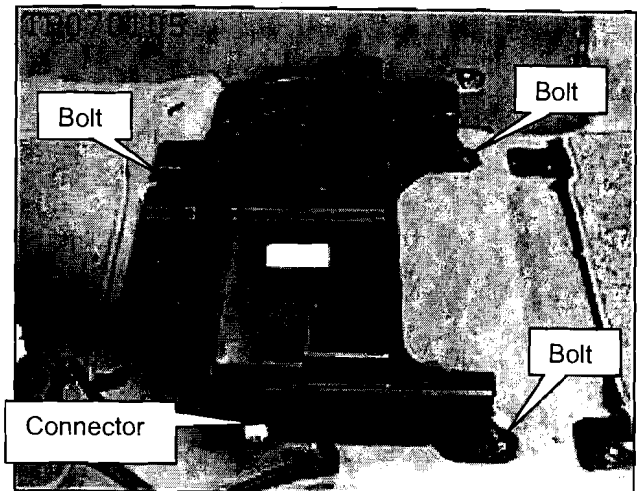

Figure C2

Navigation Control Unit—under passenger seat

- a. Remove the control unit cover; 2 bolts.

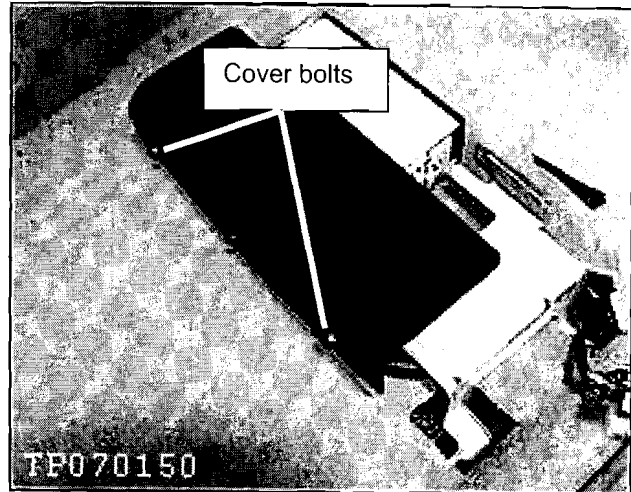

Figure C3

- b. Disconnect the electrical connectors.

Remove the 3 mounting bolts.

- d. Remove the control unit from the vehicle.

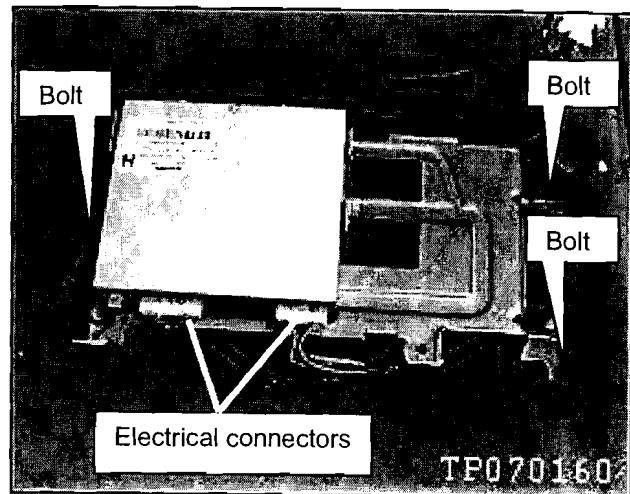

Figure C4

7. If equipped with front bench seat (shifter on steering column), remove the center seat and cup holder:

- a. Remove the finisher at the rear of the center seat.

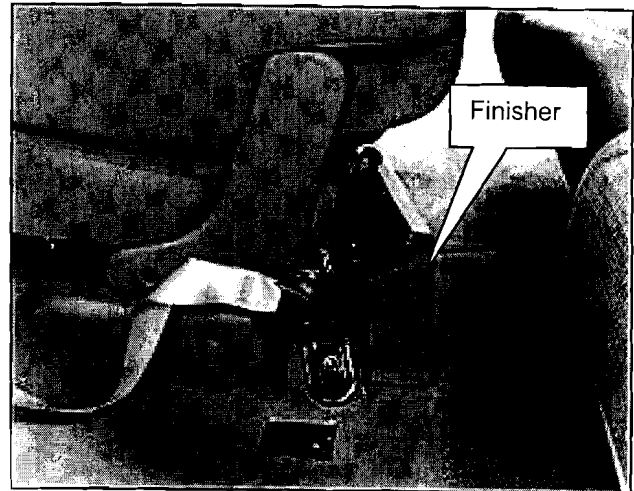

Figure C5

- a. Remove the 4 center seat mounting bolts.
- b. Remove the seat from the vehicle and place it in a clean area.

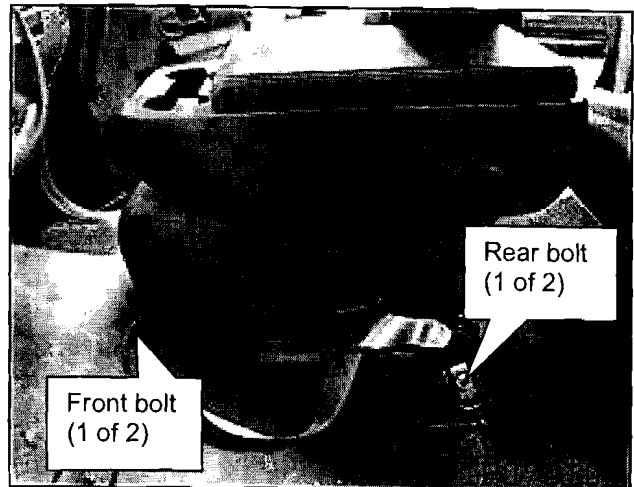

Figure C6

- c. Remove 2 cup holder mounting bolts.
- Left side is shown, right side not shown
- b. Remove the cup holder from the vehicle.

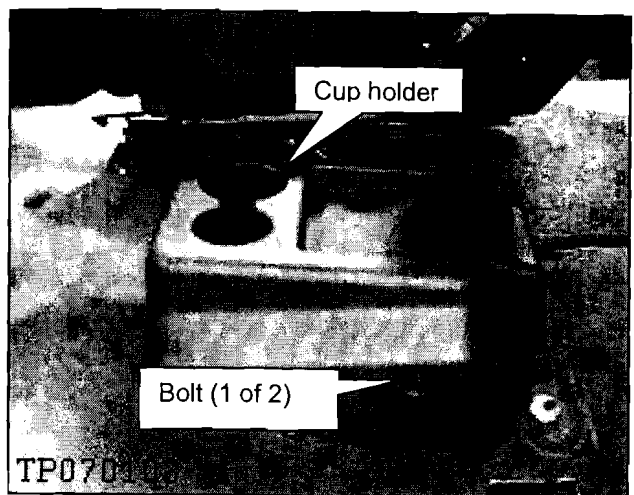

Figure C7

8. If equipped with front bucket seats (shifter is in the center console); remove the center console:
 - a. Remove 2 screws from the bottom of the glove box assembly.

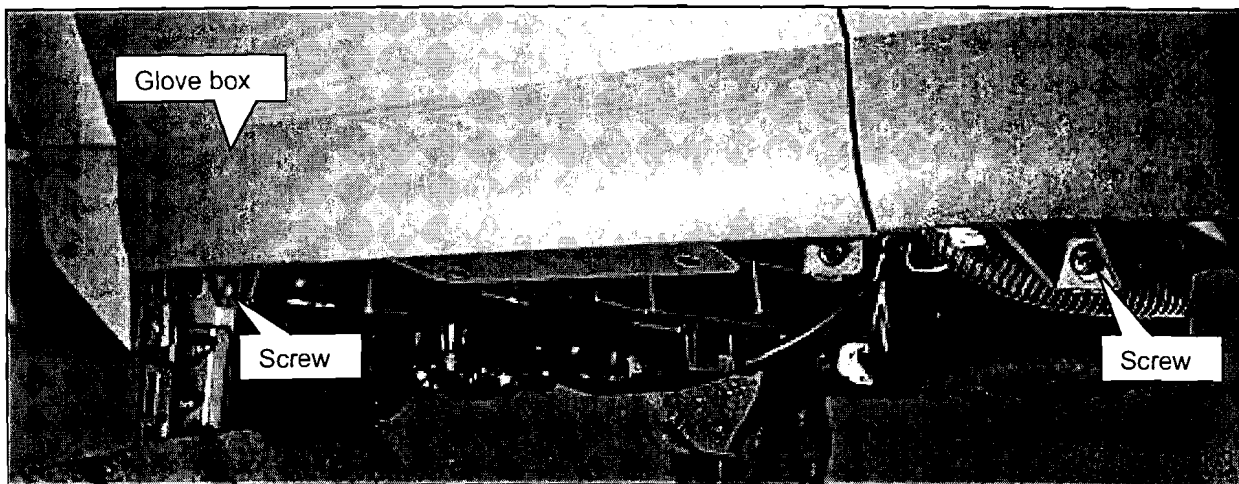

Figure C8

- b. Remove 4 screws at the top of the glove box assembly, then
 - c. Remove the glove box assembly.

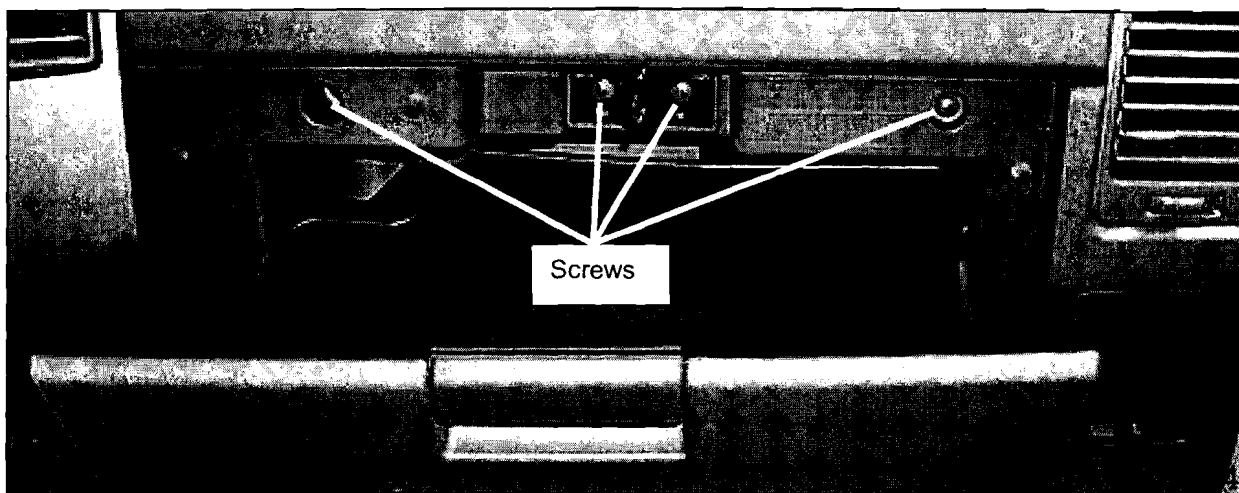

Figure C9

- d. At the front of the console; remove side covers and screws.
- Left side cover shown; remove right side cover also.
 - 1 screw on each side.

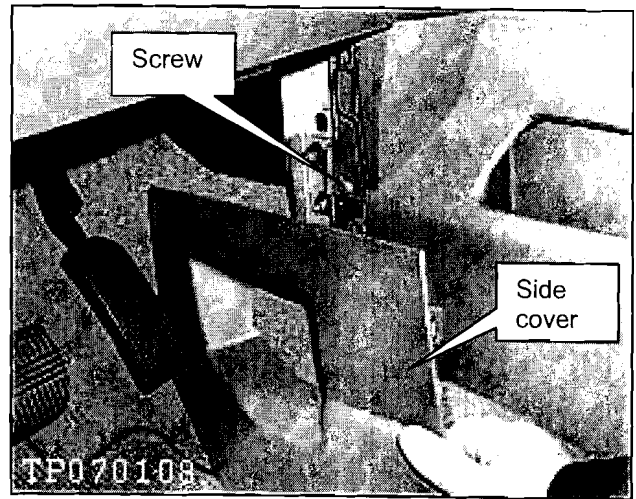

Figure C10

- e. Remove the shift knob; unscrew it counterclockwise.

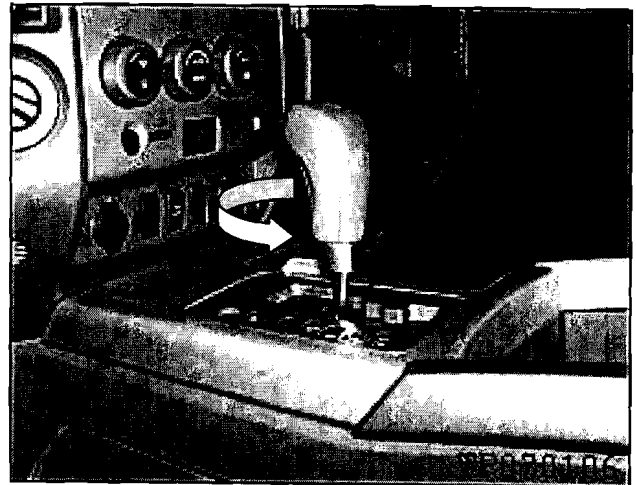

Figure C11

Lift and remove the shift finisher.

- Disconnect electrical connectors.

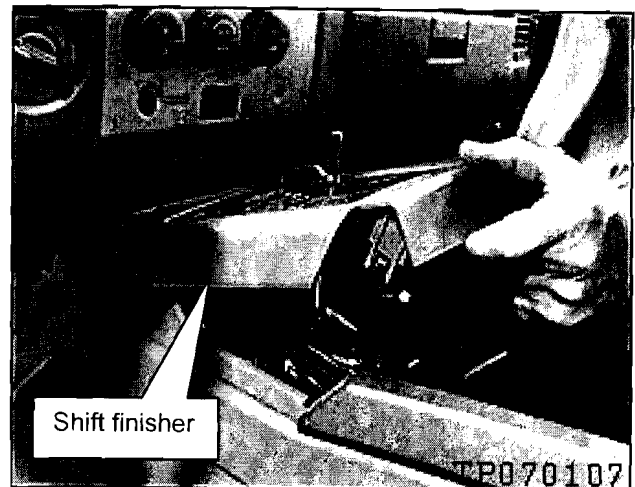

Figure C12

- g. Disconnect the shift cable.
 - Push the shift lever release to move shift lever to Park.
- h. Take the shift finisher harness loose from the console.

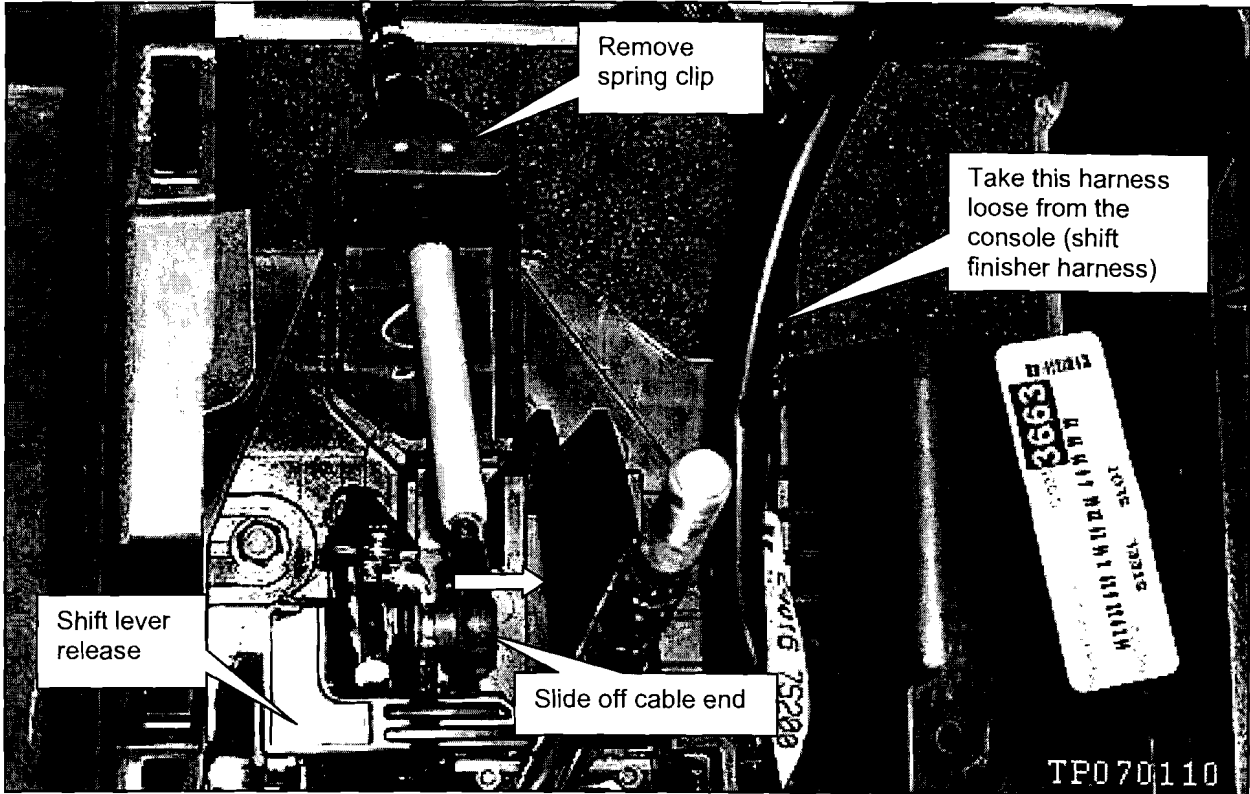

Figure C13

- i. At the front of the console, release harness mounting clips, disconnect harness connector, and remove 2 screws.

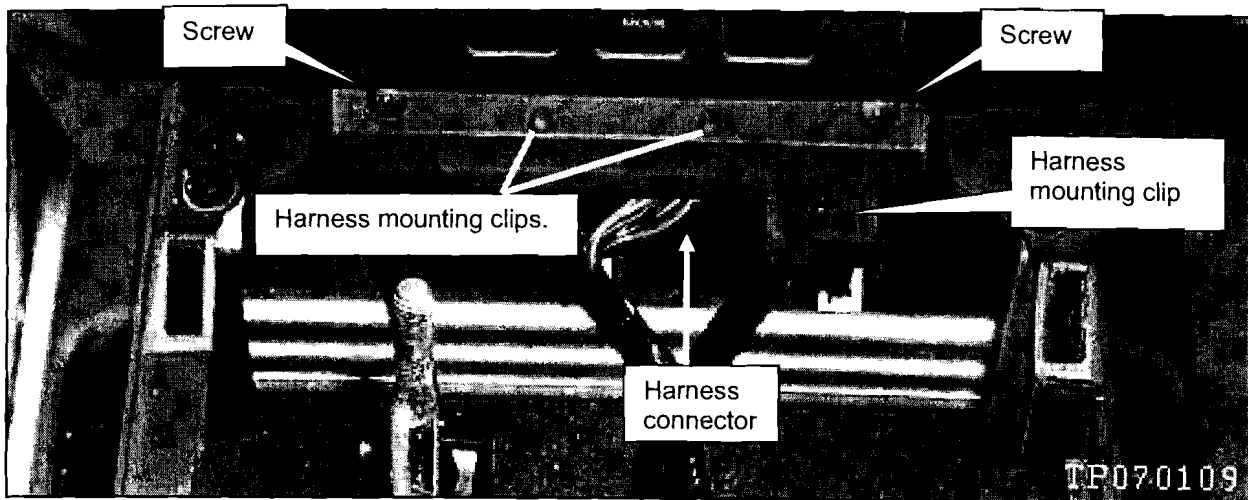

Figure C14

Remove 4 screws from the bottom of the console compartments.

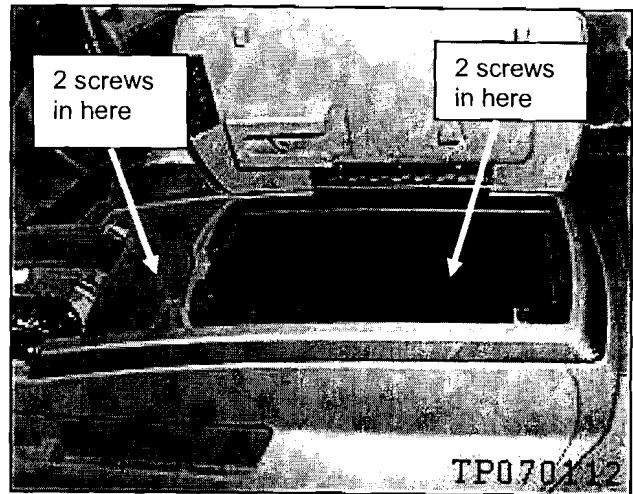

Figure C15

k. Remove 2 bolts from the sides of the console.

- Left side is shown, right side not shown.

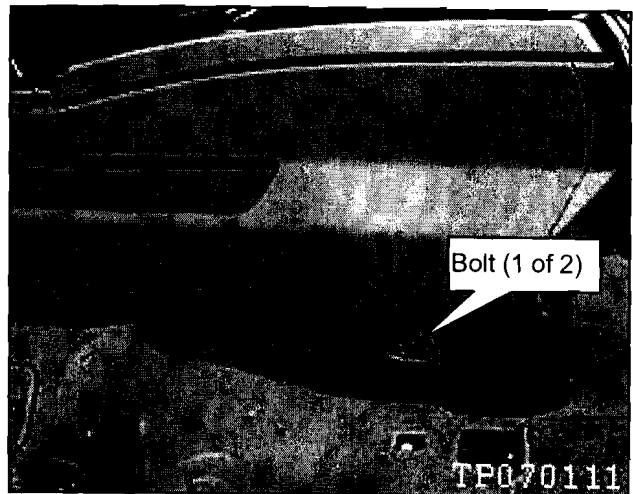

Figure C16

l. Remove the center console from the vehicle.

9. Disconnect the harness SRS connector from the SRS control unit.

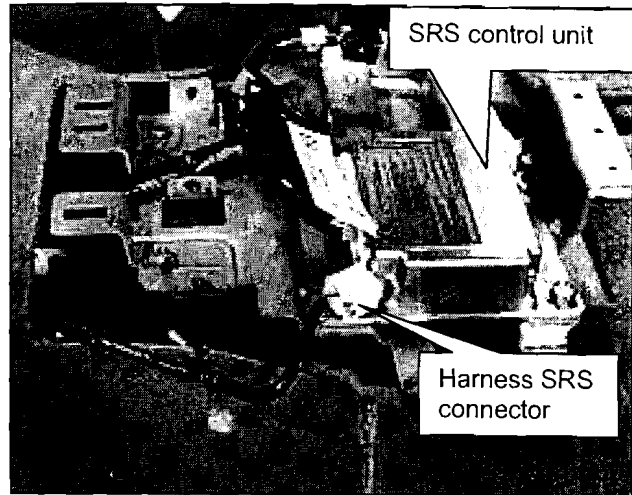

Figure C17

10. Remove the rear seat from the vehicle:
 - a. Move the jack out of the way.
 - b. Remove the center seat belt retractor anchor bolt.
 - c. Remove the 8 seat mounting bolts.
 - d. Remove the seat from the vehicle and place it in a clean area.

NOTE: Use two people to lift the rear seat out of the vehicle.

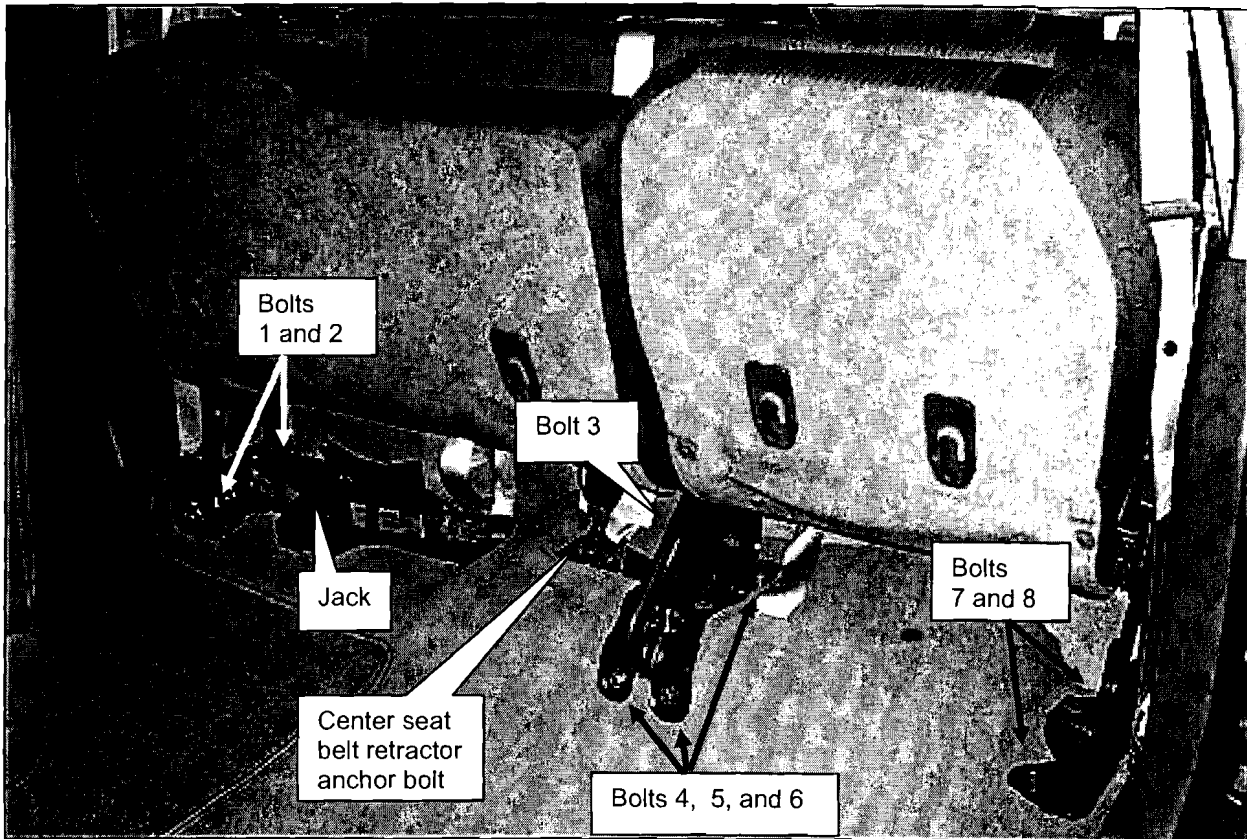

Figure C18

11. Remove the front kick plate.

- Use a plastic trim tool to snap it loose.

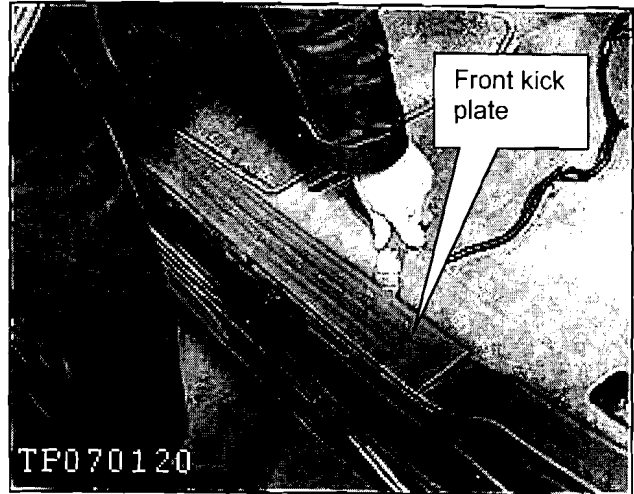

Figure C19

12. Remove the rear kick plate;

- Use a plastic trim tool to snap it loose.

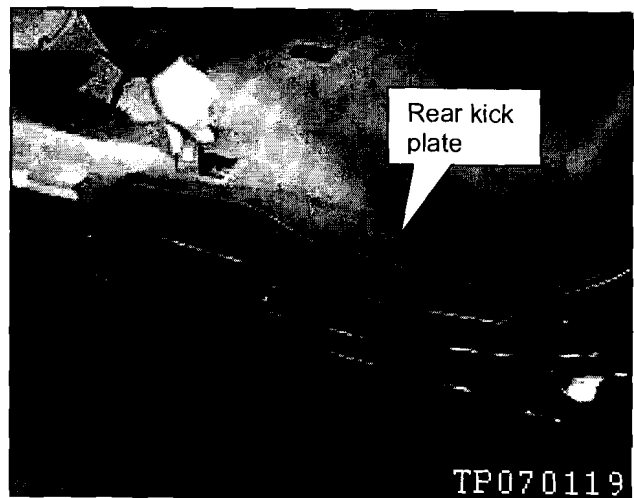

Figure C20

13. Remove the lower dash side finisher.

- There is a plastic clip behind the parking brake lever.

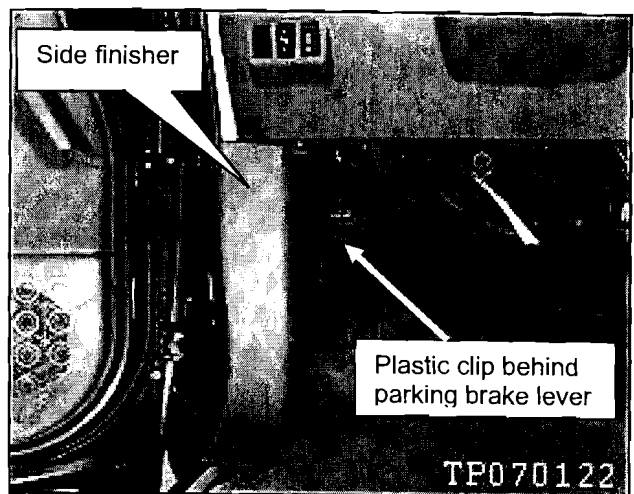

Figure C21

14. Disconnect each of the connectors on the connector support.

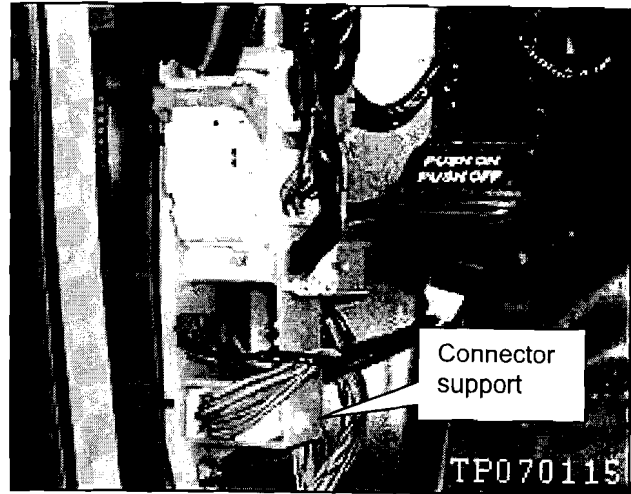

Figure C22

15. Remove connectors from support.

For each connector that is not part of the body harness:

- a. Use a small flat blade screwdriver to unlock the connector mounts,
- b. Then slide the connectors forward to remove them from the connector support.

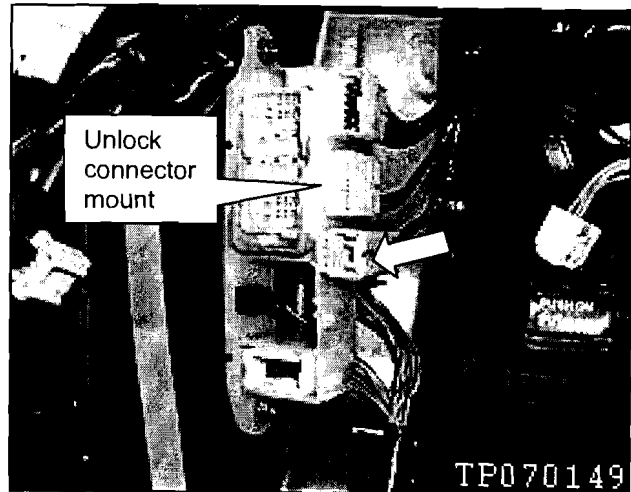

Figure C23

- c. Remove the 2 connector support bolts.
- d. Slide the connector support LIP to remove it.

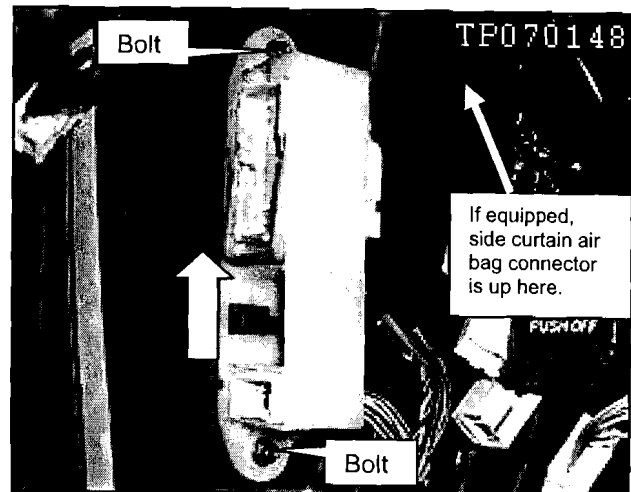

Figure C24

16. If equipped with side curtain air bags:

- If you are replacing the **passenger side** harness; steps for disconnecting the side curtain air bag will be covered later in this procedure.

If you are replacing the driver side harness, disconnect the side curtain air bag as follows.

- a. Remove the 3 mounting nuts for the parking brake pedal assembly and move the assembly out of the way.

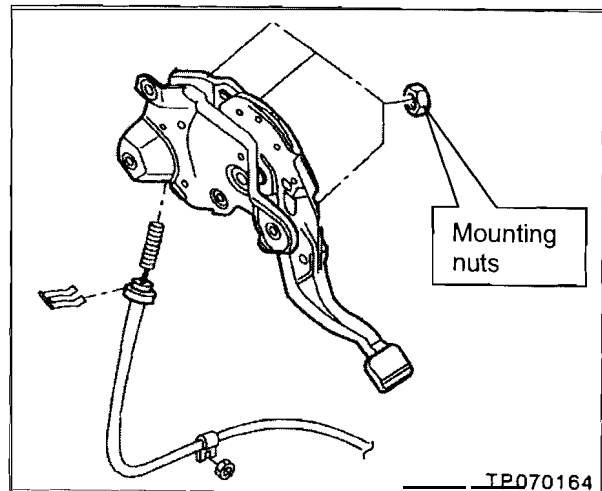

Figure C25

- b. From the floor, look up towards the front pillar and locate the side curtain air bag connector.
- c. Disconnect the side curtain air bag.
- d. Take the harness branch loose from the body.

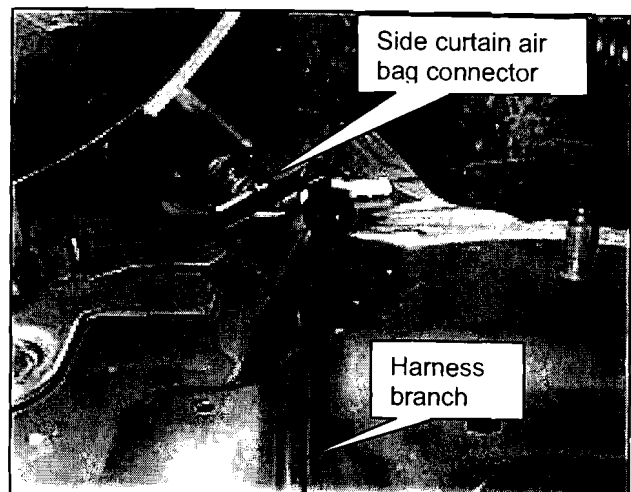

Figure C26

17. Remove the lower anchor bolt for the rear seat belt.

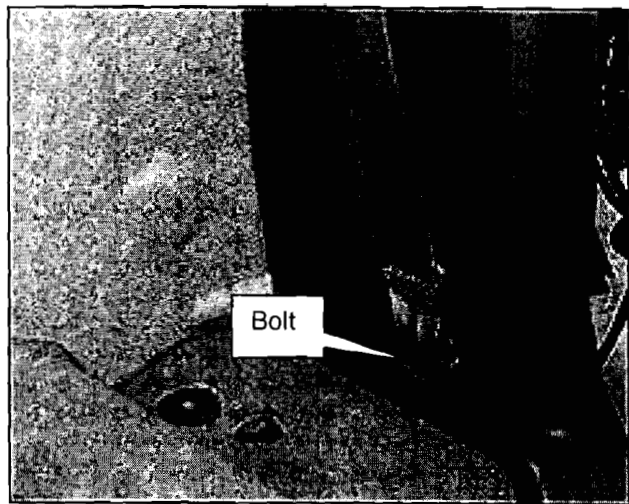

Figure C27

18. Remove the lower side finisher.

- Use a plastic trim tool.

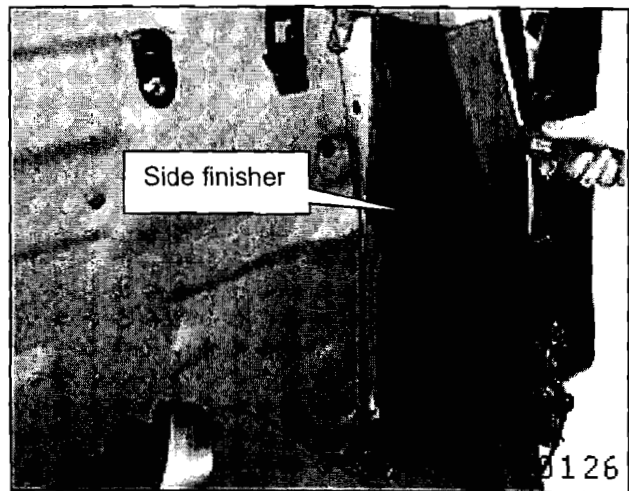

Figure C28

19. Remove the seat belt retractor; 1 bolt.

20. Remove the harness ground bolt.

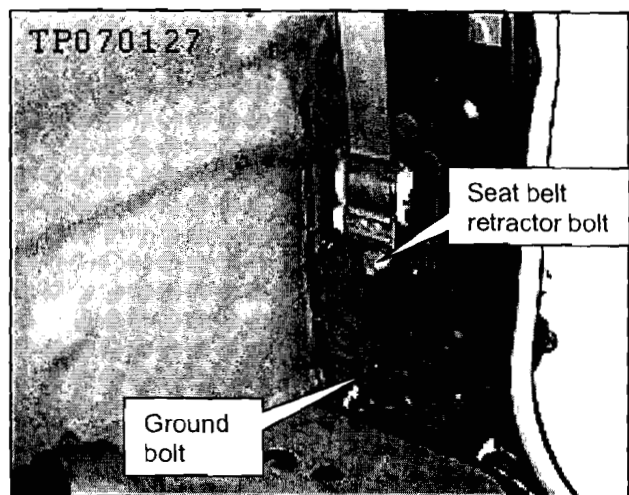

Figure C29

21. Remove the floor mat holder.

22. Remove the carpet clips shown in the figure below.

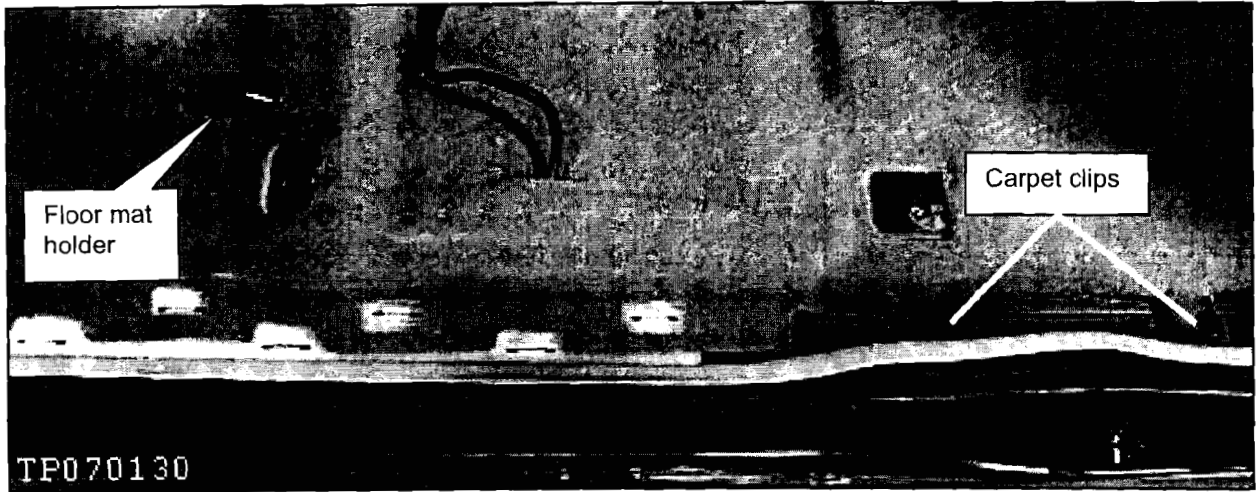

Figure C30

23. Pull the seat branch through the carpet.

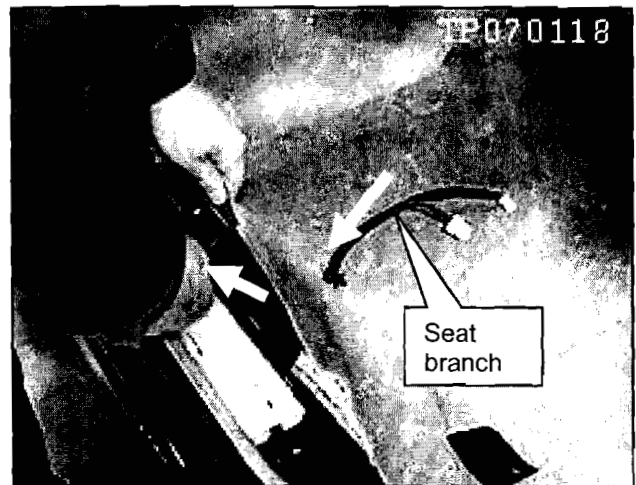

Figure C31

24. Lift the floor carpet, remove the ground bolt and take the SRS branch loose from the floor.

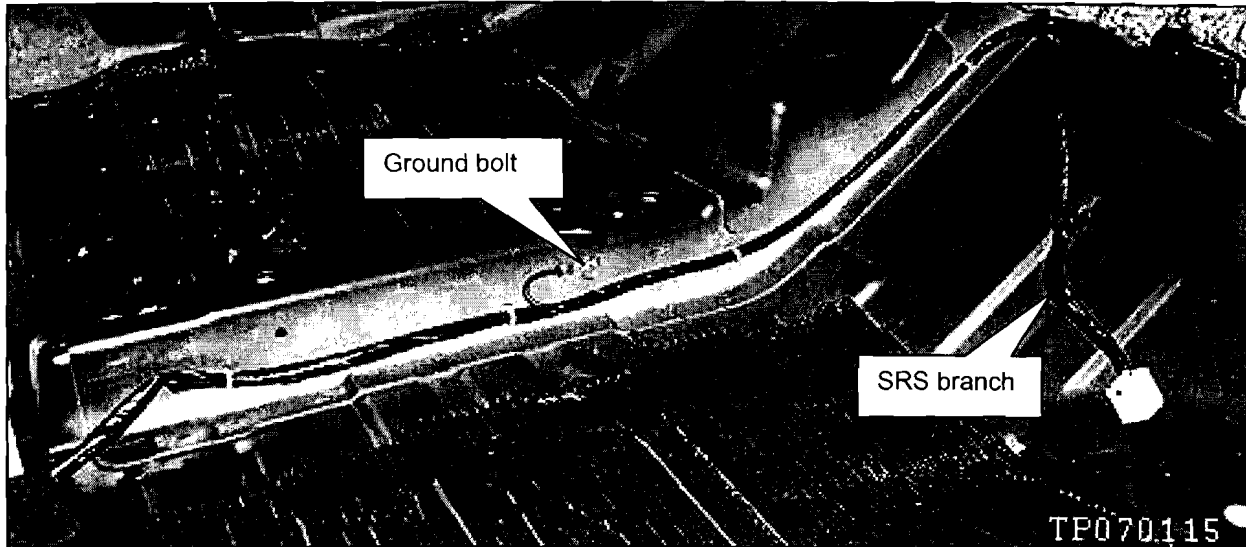

Figure C32

25. Snap the plastic harness protector loose from the floor.

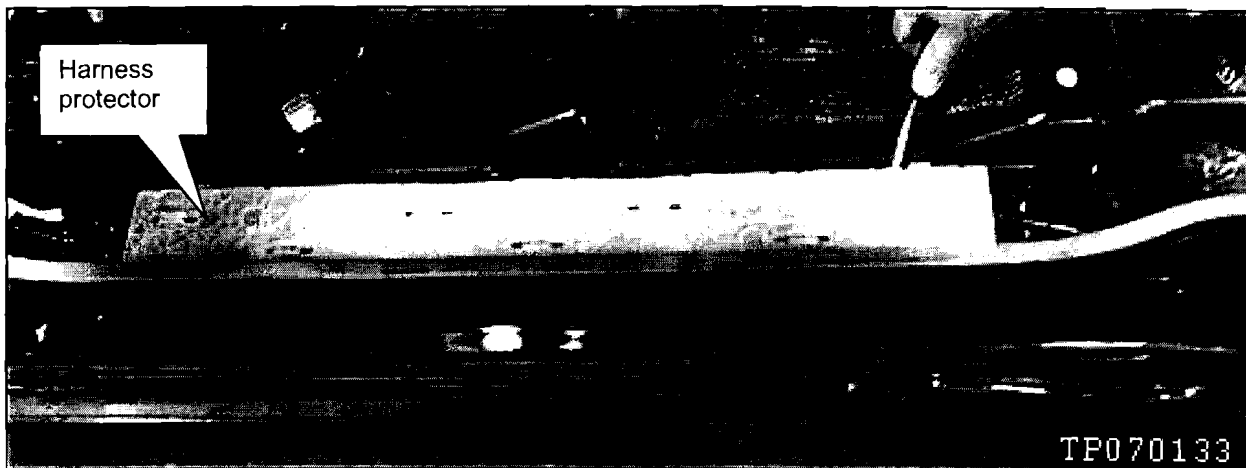

Figure C33

26. Take the harness loose from along the floor.

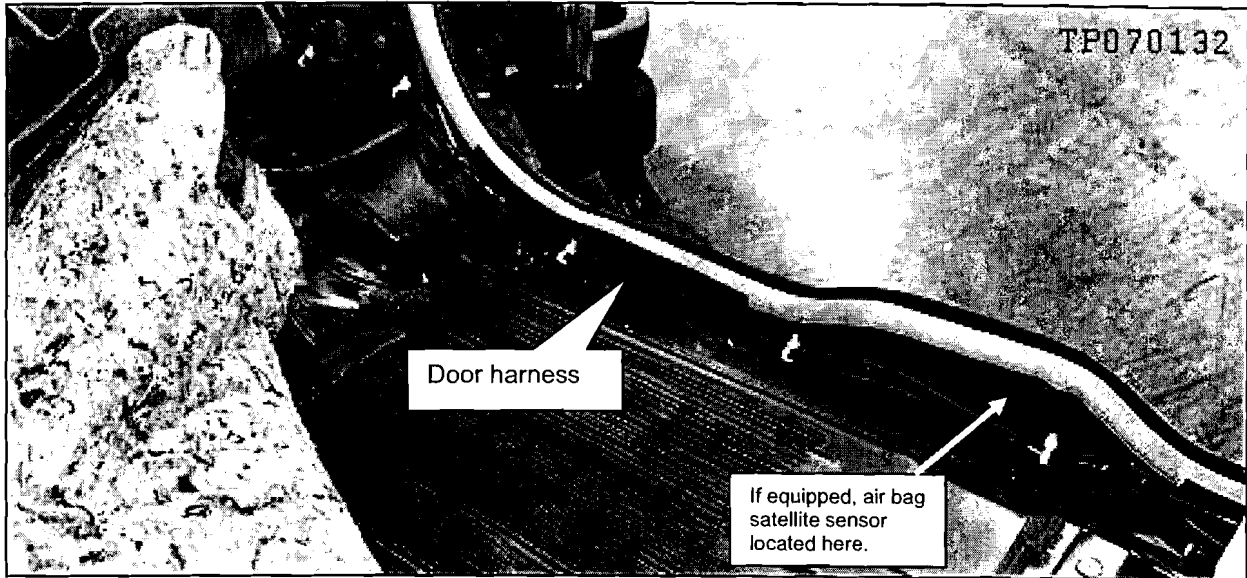

Figure C34

NOTE: If the vehicle is equipped with side curtain air bags, disconnect the air bag satellite sensor that's located on the rocker panel (see figure above).

27. On the rear door, remove the lower seat belt anchor bolt.

NOTE: For the passenger side, this bolt does not need to be removed unless you are going to replace the seat belt.

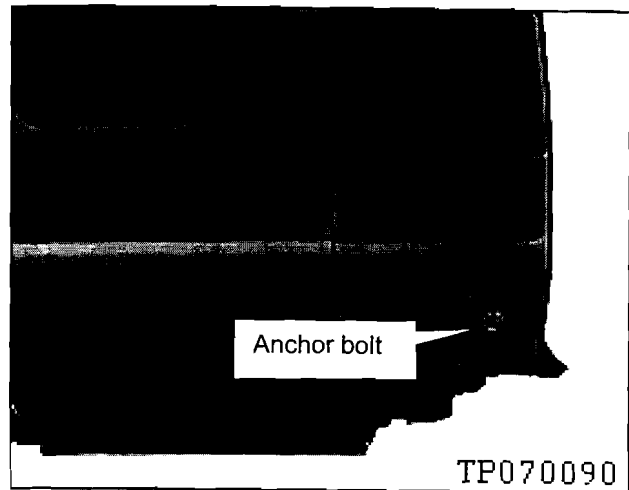

Figure C35

28. Remove the seatbelt retractor cover.

- Use a plastic trim tool.

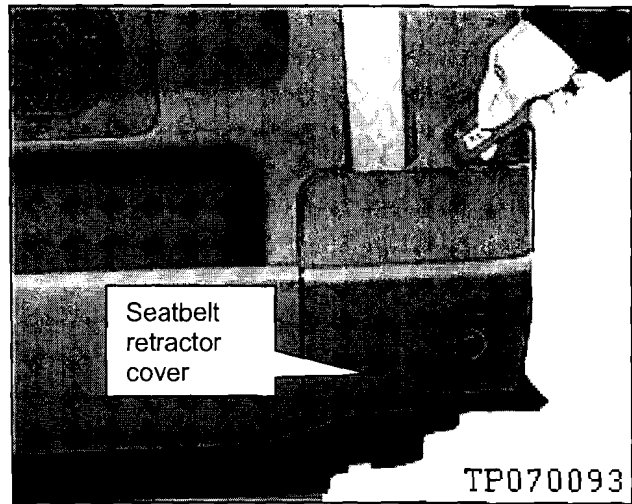

Figure C36

29. Carefully remove the D-ring bolt cover.



Figure C37

30. Remove the D-ring bolt.

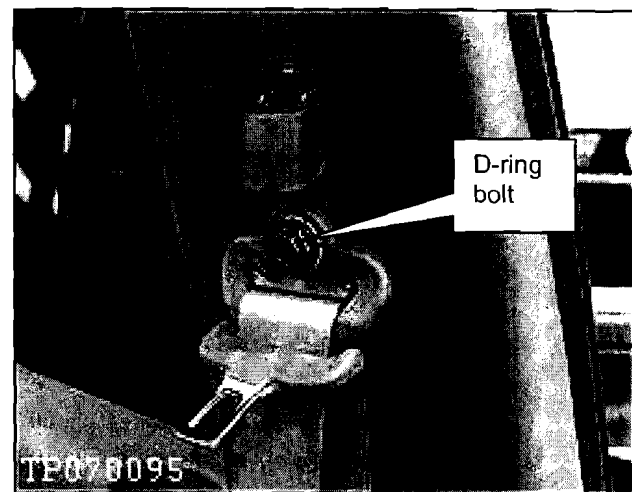

Figure C38

31. Snap loose the armrest.

- Use a plastic trim tool.

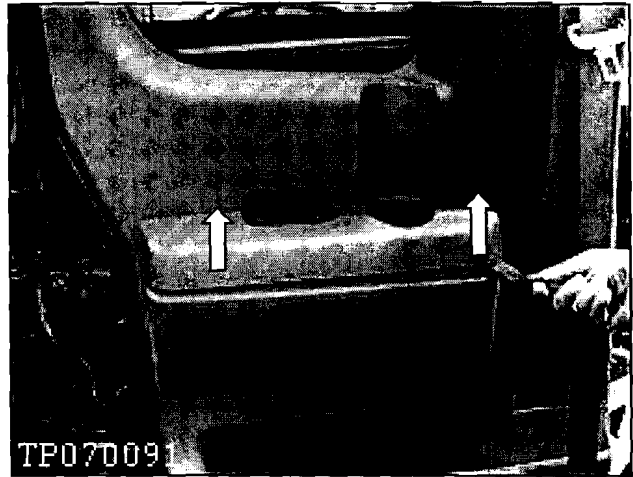

Figure C39

32. Remove the 3 bolts shown in Figure C40.

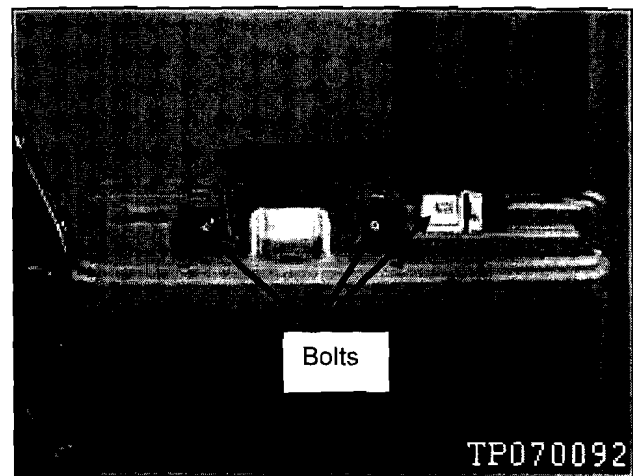

Figure C40

33. Remove the rear door panel.

- Use a plastic trim tool.



Figure C41

34. Disconnect the 5 connectors shown in the figure below.

NOTE: The passenger side will have a 6th connector (not shown).

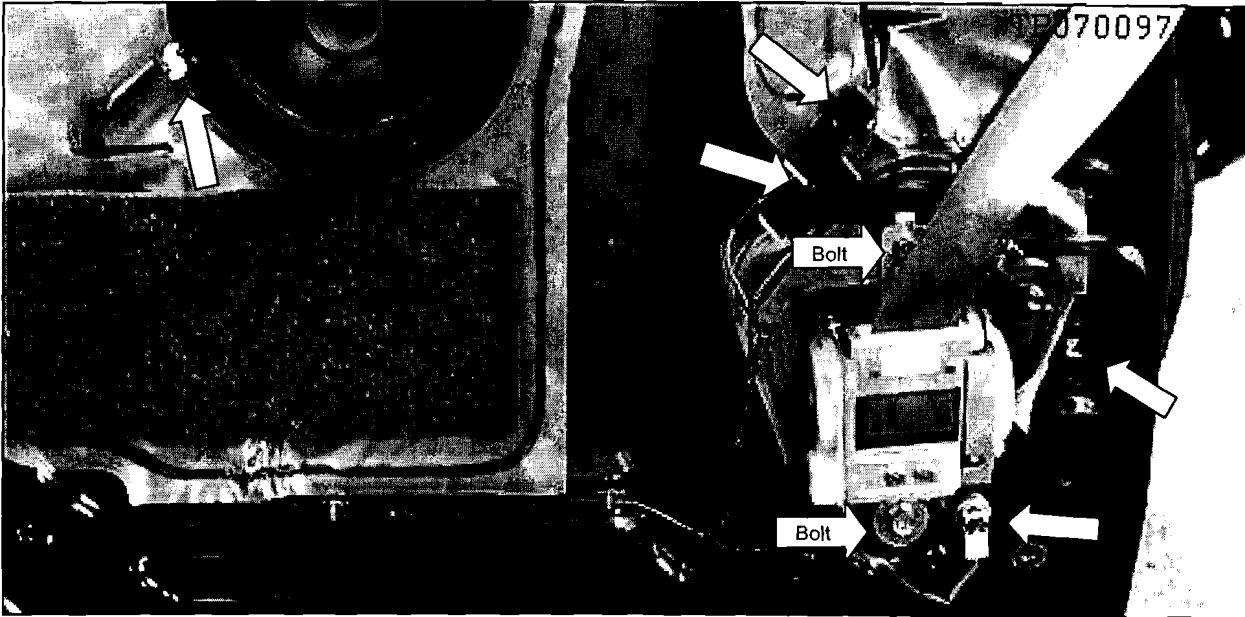

Figure C42

35. If the result for Inspection Procedure 1 was NG (seat belt retractor will not extend or retract; remove the 2 seat belt retractor bolts and remove the seat belt.

- During reassembly, install a new seat belt.

NOTE: Seat belt retractor with seat belt pretensioner should be disposed of in accordance with local and state regulations.

36. Take the harness loose from the door mounting points.

37. Pull the harness out of the door.

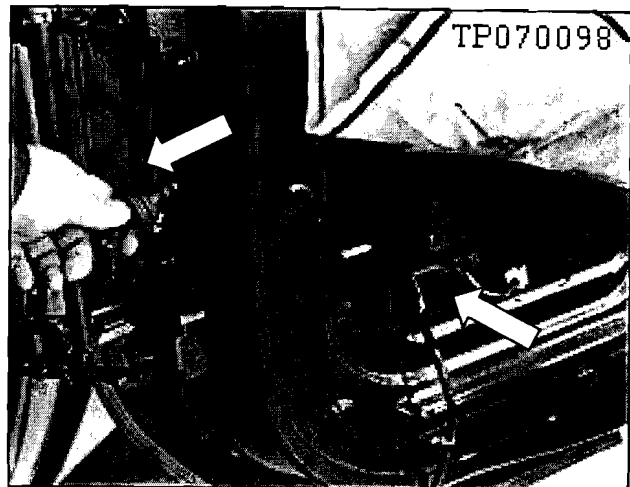

Figure C43

38. Remove the upper door hinge finisher;
2 clips.

39. Take the harness loose from the hinge
rod and the body.

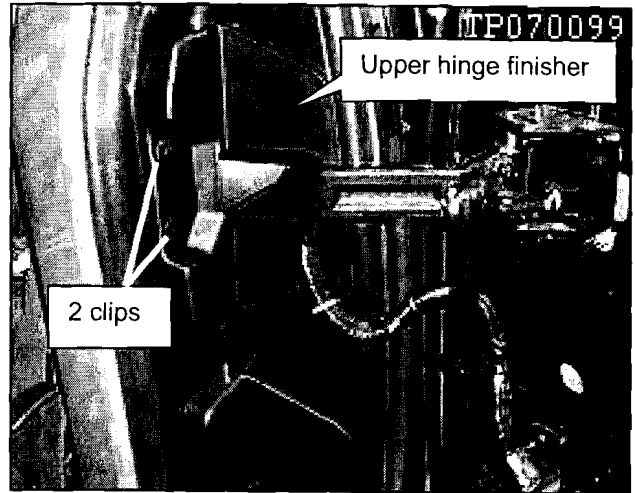

Figure C44

40. Pull the harness through the body.

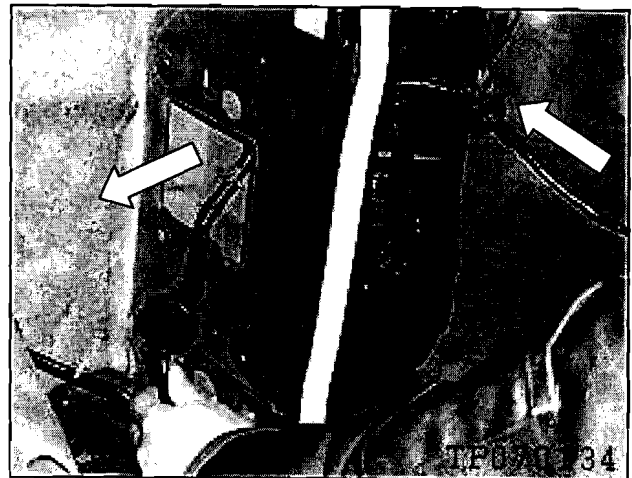

Figure C45

For passenger side (right side) harness, go to step 51

Rear Cabin Wall Harness Branch (driver side—left side—only; if equipped with rear sonar and/or differential lock

41. Lift the carpet on the rear cabin wall.

42. Disconnect the control unit(s).

43. Take the harness loose from the rear cabin wall.

44. Harness should now be completely loose—remove it from the vehicle.

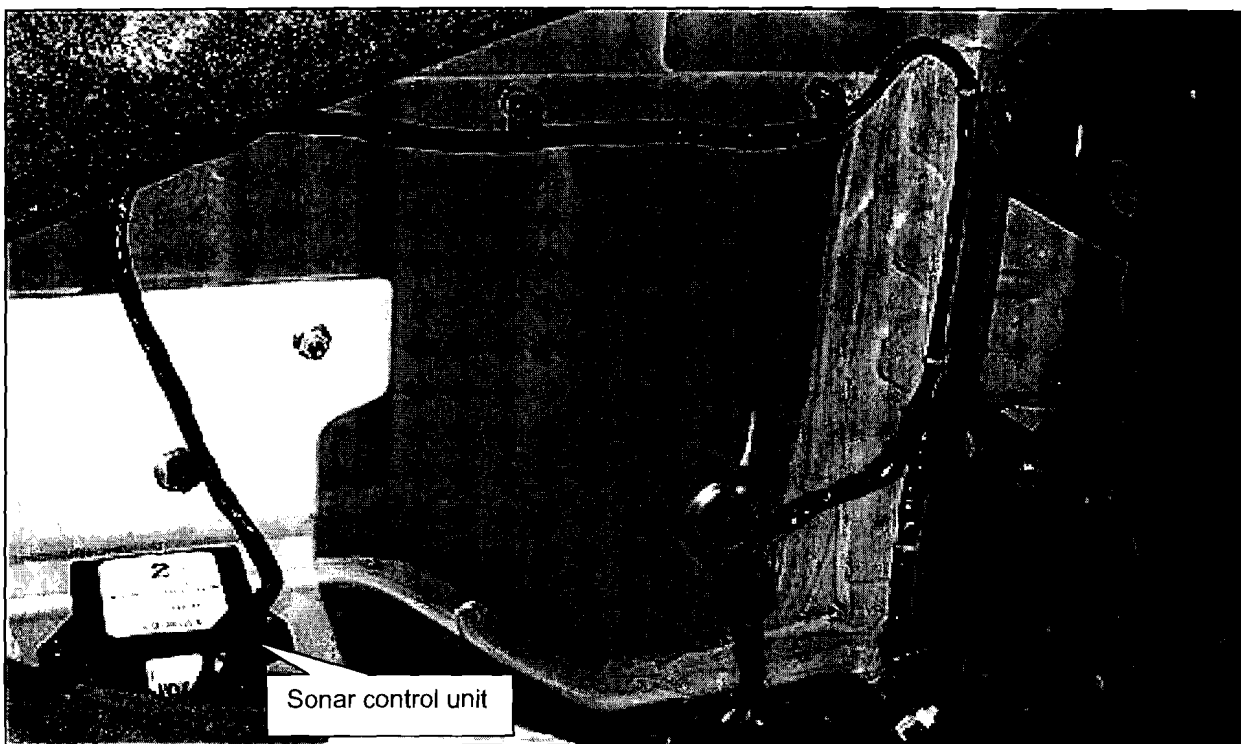

Figure C46

NOTE: The vehicle you are working on may have a differential lock control unit (not shown) mounted near the sonar control unit.

45. Install the new harness in reverse order. Make sure of the following:

- All harness mounting clips are installed in the correct locations.
- Seat, seat belt, and parking brake pedal bolts are tightened to correct torque:

Parking Brake Pedal Mounting Bolts	12.7 N.m (1.3 k-gm, 9 ft-lb)
Front Seat Belt Anchor, Retractor, D-Ring	49 N.m (5.0 k-gm, 36 ft-lb)
Rear Seat Belt Anchor, Retractor, D-Ring	55.8 N.m (5.7 k-gm, 41 ft-lb)
Rear Seat Mounting Bolts	46.6 N.m (4.8 k-gm, 34 ft-lb)
Front Seat Mounting Bolts	45 N.m (4.6 k-gm, 33 ft-lb)

IMPORTANT:

- During installation of the new harness you will find some connectors taped to the harness as shown in the figure below.
- Some of the connectors will be for options that the vehicle you are working on does not have.
- Un-tape the connectors that are needed. Leave the connectors you don't need taped to the harness.

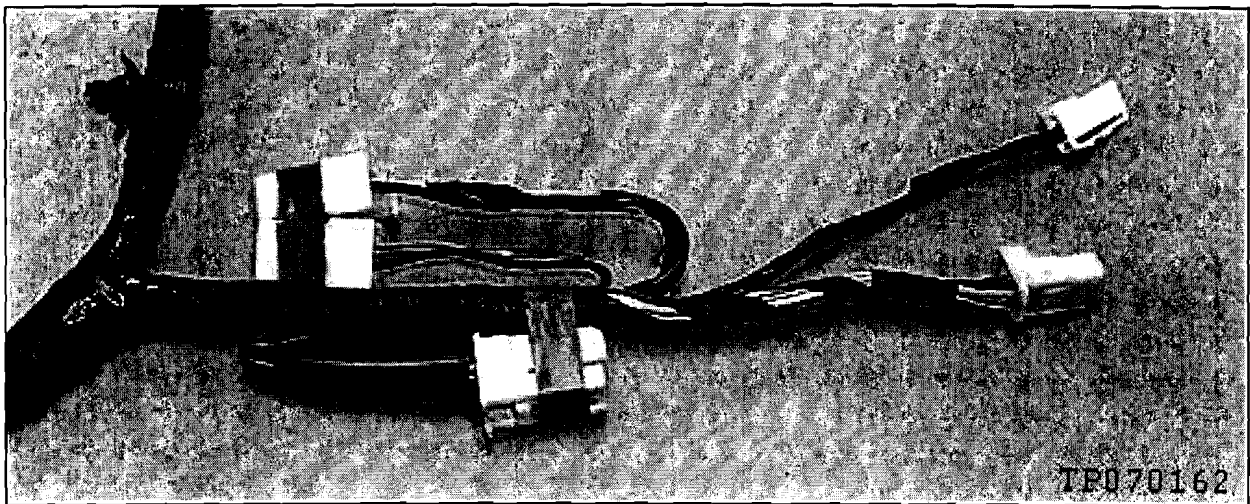

Figure C47

46. Connect both battery cables—positive cable first.

47. Reset the radio station presets.

48. If Inspection Procedure 1 was NG, or Inspection Procedure 2 result was "light stays on or blinks"; connect CONSULT-II and clear codes from the Air Bag Control Unit SELF-DIAG [PAST].

Final Quality Checks

49. Check the air bag light operation as follows:

- a. Turn the ignition OFF and then ON.
- b. Observe the air bag warning light.
- c. Make sure the air bag warning light comes on for 7 seconds and then goes out.

50. Confirm that all systems related to the harness replacement are functioning correctly.

High Mount Stop Lamp Harness Branch (Passenger Side — Right Side — Only)

51. Remove the rear seat belt D-ring covers and bolts—left and right side.

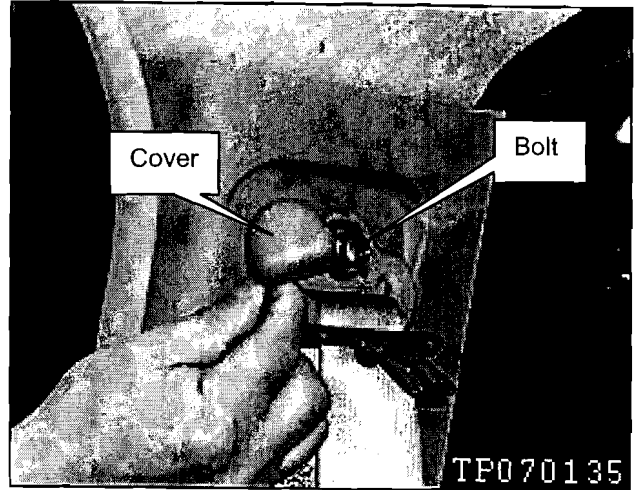

Figure D1

52. Remove the rear upper finishers—left and right side.

- Remove the clip.
- Use a plastic trim tool.

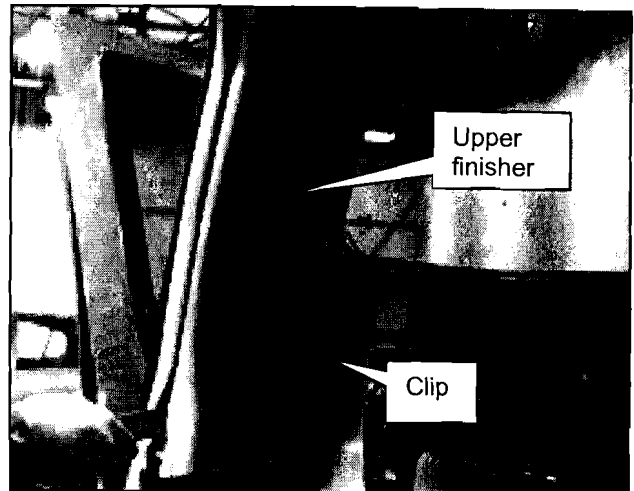

Figure D2

53 Remove the upper door latch striker covers—left and right side.

- 1 screw on each side.

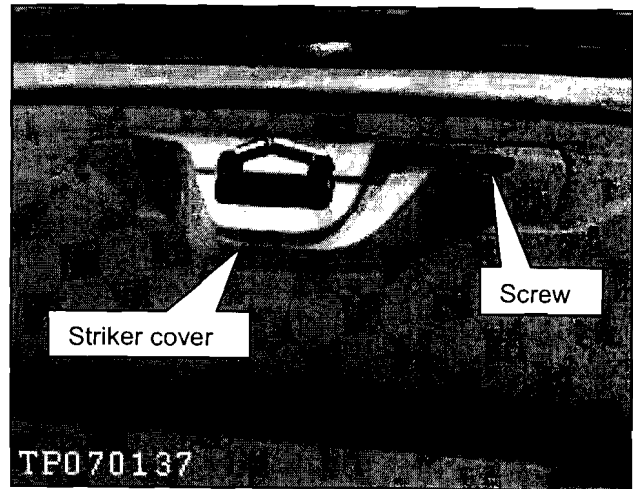

Figure D3

54. Remove the coat hangers; left and right side.

- 1 screw for each coat hanger.

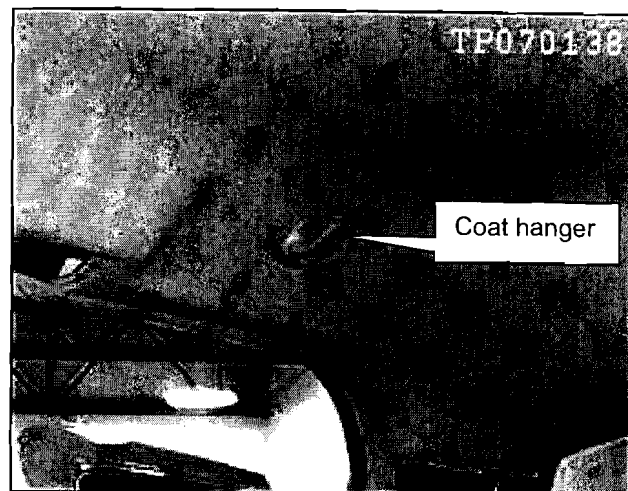

Figure D4

55. Remove the assist grip (passenger side only).

- Open the side bolt covers.
- Remove the 2 bolts.

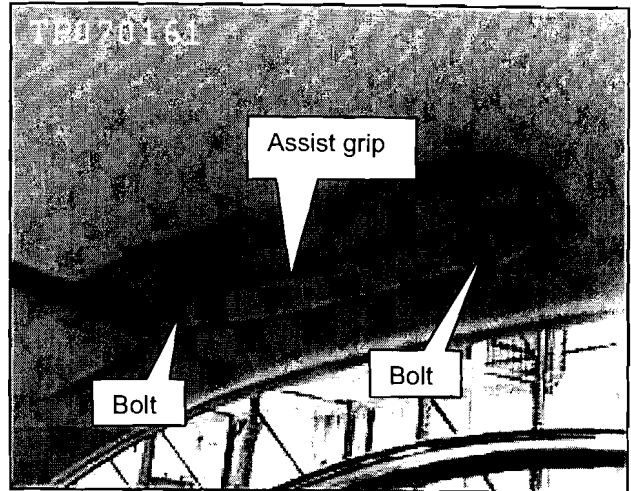

Figure D5

56. Remove the dome lamp.

- a. Remove the clear lamp cover
- b. Remove the 2 screws.
- c. Let the lamp hang by the electrical connector.

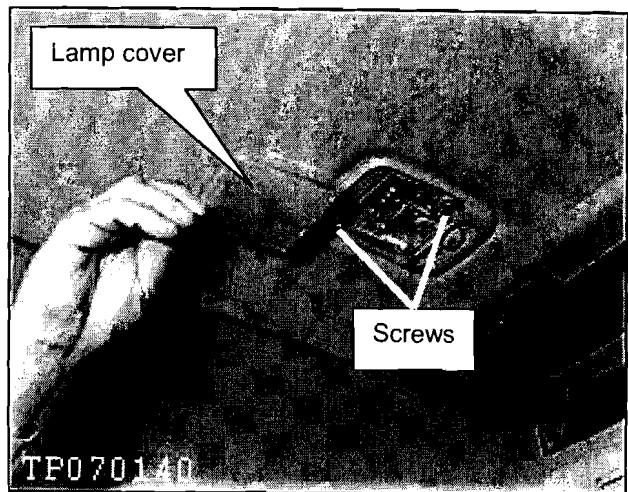

Figure D6

57. Remove the 5 screws (shown in the figure below) from the center roof console.

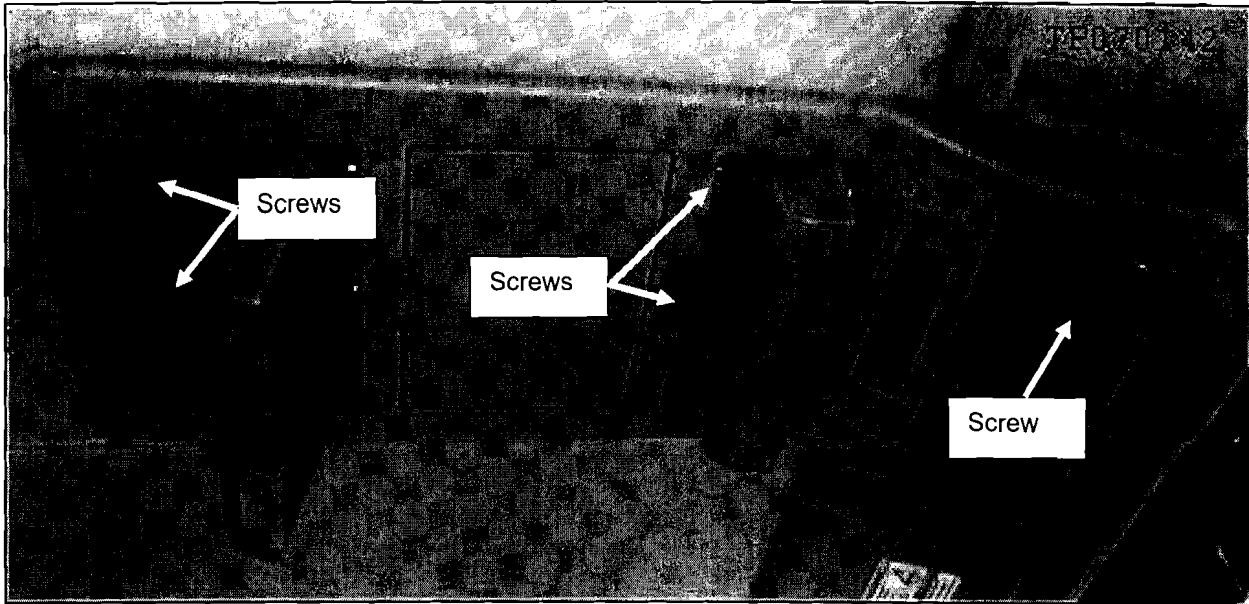

Figure D7

58. Pull the console loose at the rear and let it hang in place.

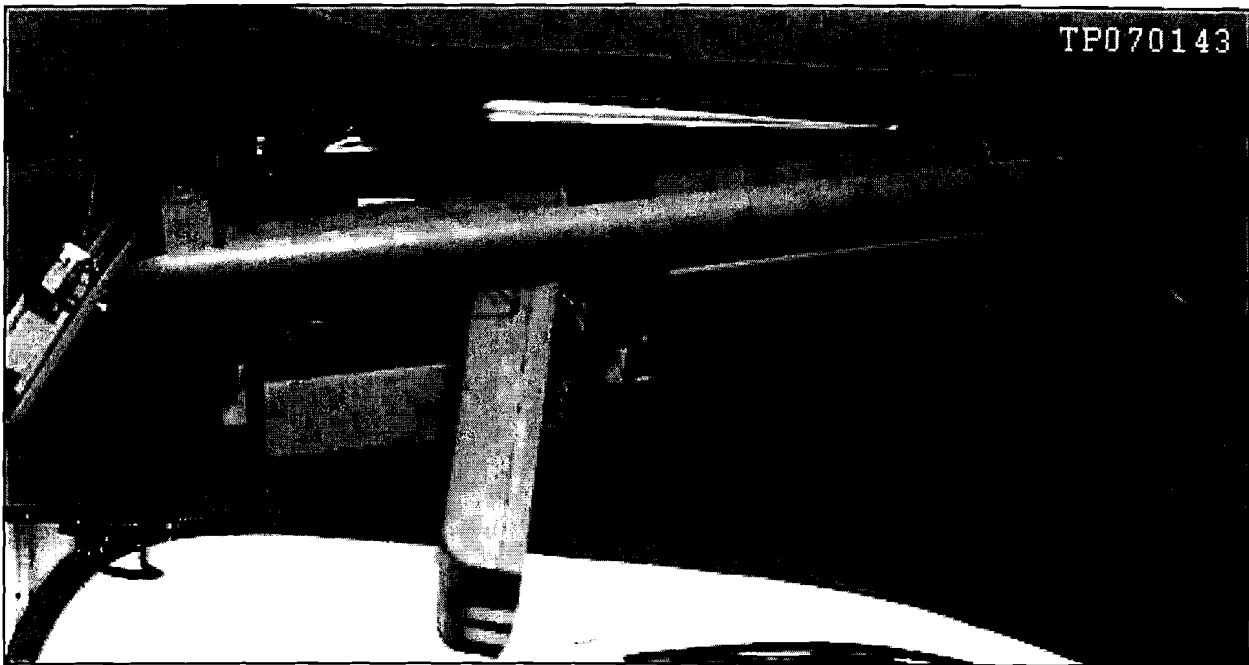

Figure D8

59. Pull the door welt loose from the top and rear of the door opening.

CAUTION: Don't get butyl sealer from the welt on any of the interior trim surfaces.

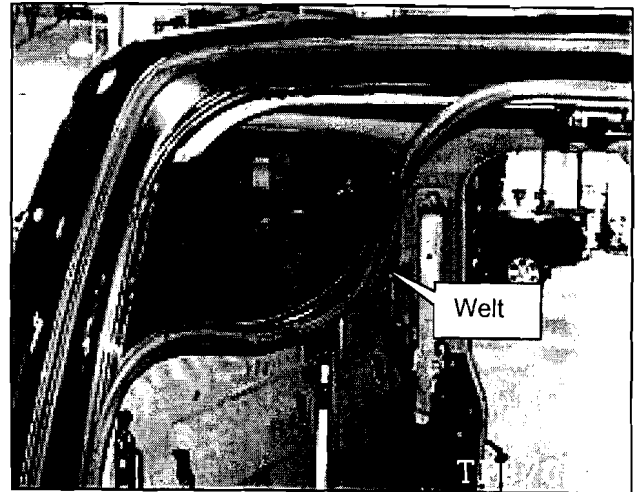

Figure D9

60. Carefully pull down the side of the headlining at the rear just enough to get your arm above it.

61. Reach above the headlining and pop loose the rear clips (left and right side).

- 2 clips on each side.

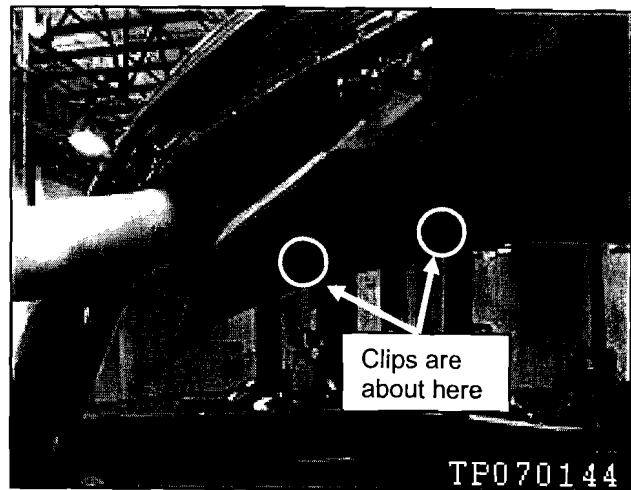

Figure D10

62. Look above the headlining, locate and disconnect the high mount brake light connector.

63. Take the harness loose from the body roof.

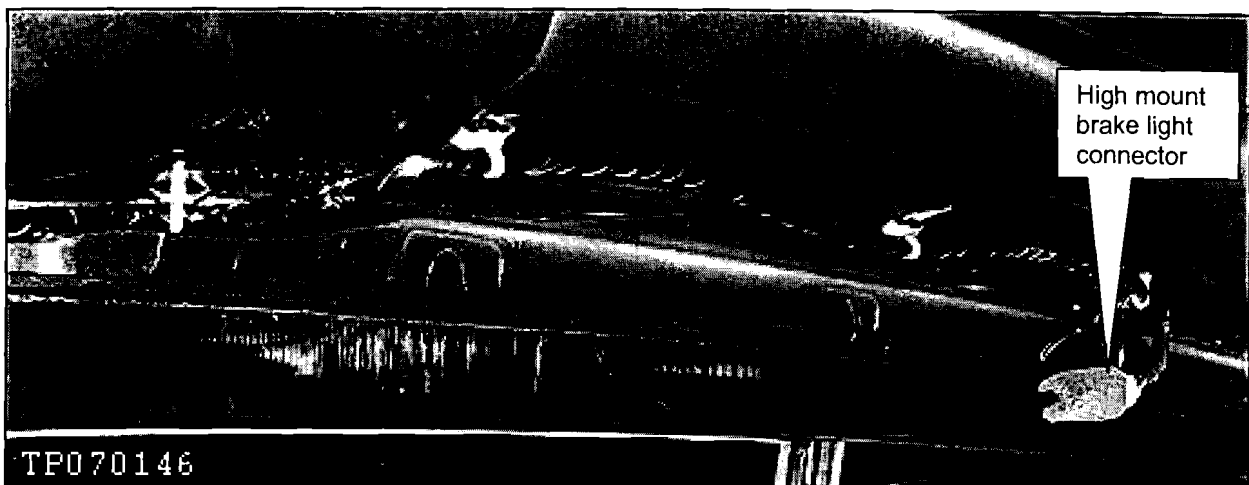

Figure D11

64. Take the harness loose from the side of the cabin.

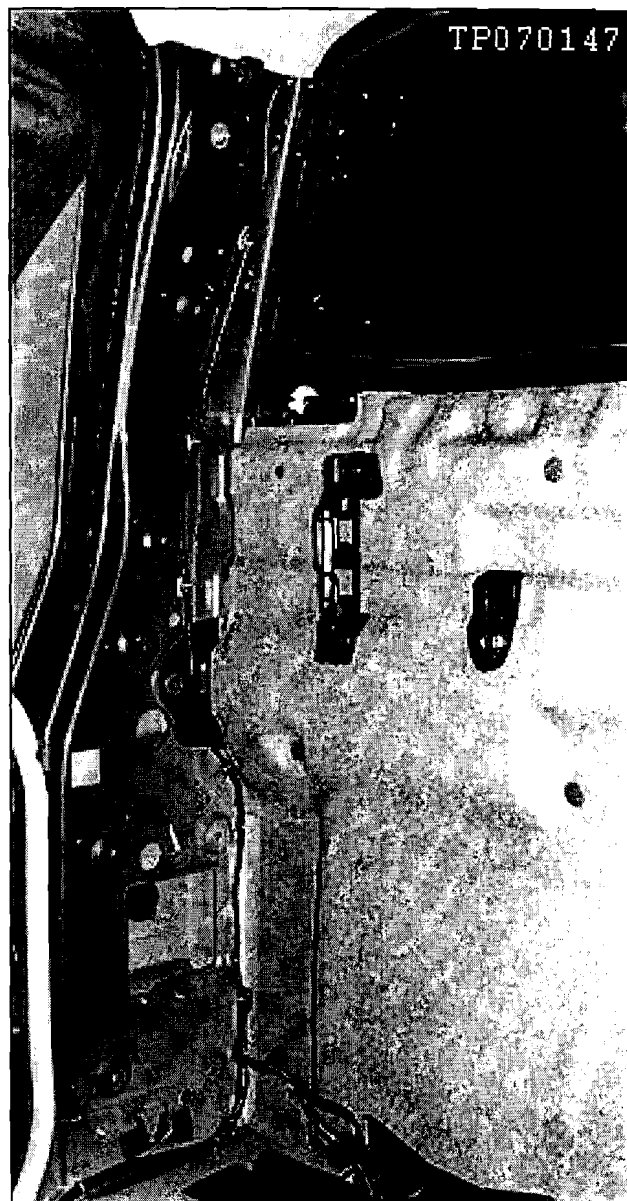

Figure D12

65. **If equipped with side curtain air bags;** disconnect the side curtain air bag module as follows:

- a. Remove the right side sun visor, 2 screws under the trim cover.
 - Use a plastic trim tool to remove the trim cover.
 - Disconnect the electrical connector.

- b. Remove the right side sun visor holder, twist $\frac{1}{4}$ turn to remove.

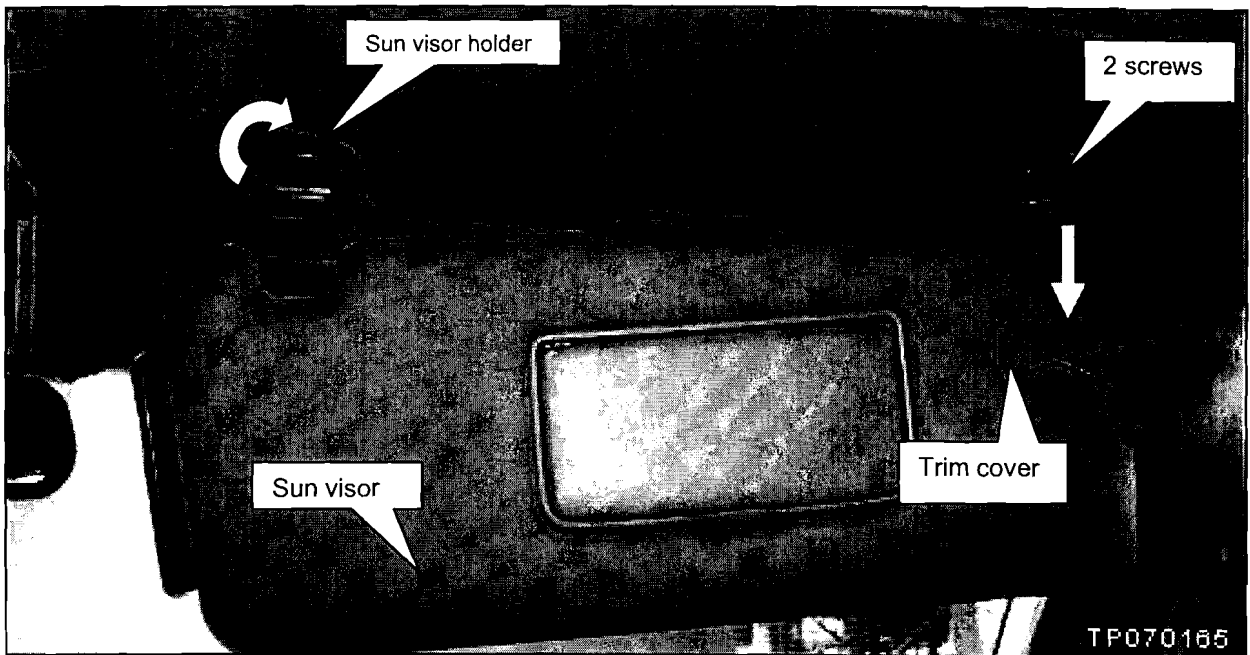

Figure D13

- c. Remove the right side dual sun visor assembly.
 - Use plastic trim tool as shown.

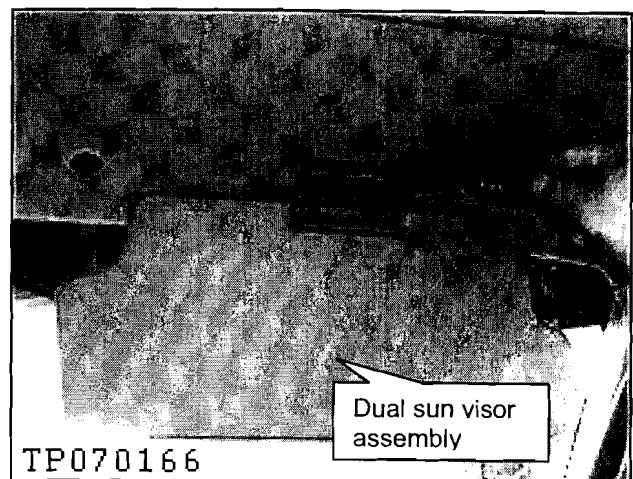

Figure D14

- d. Remove front pillar assist grip;
- 2 bolts; under end covers.

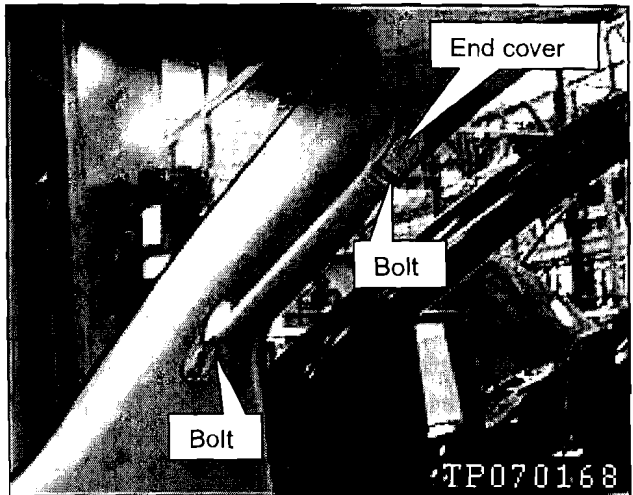

Figure D15

- e. Remove the front pillar finisher.
- Use a plastic trim tool.



Figure D16

NOTE: With the sun visor and front pillar finisher removed the headlining will be loose all along the passenger side. This will allow access to the side curtain air bag mounting bolts.

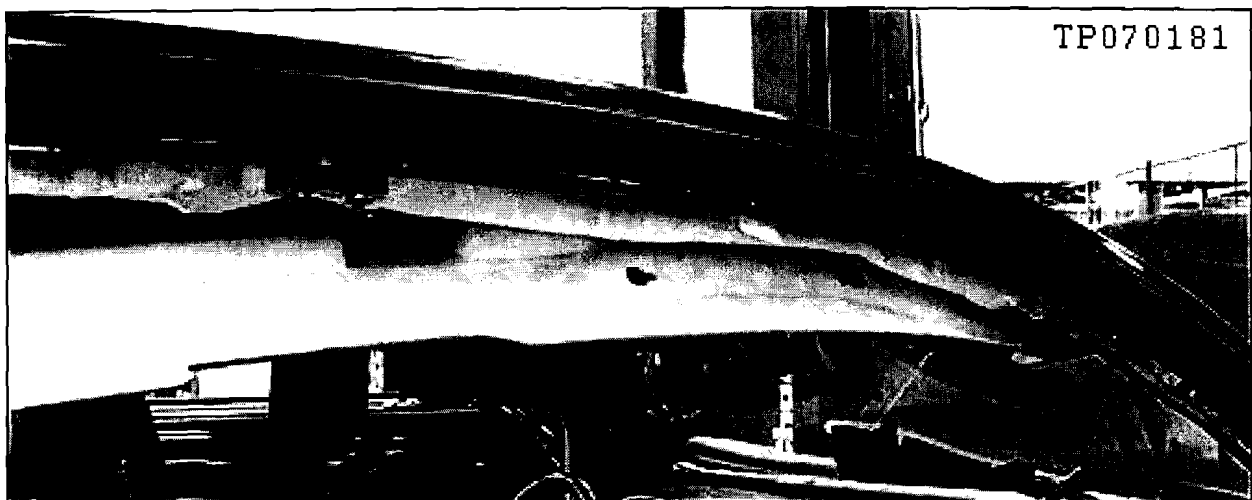

Figure D17

Take the side curtain air bag branch of the harness loose from the body.

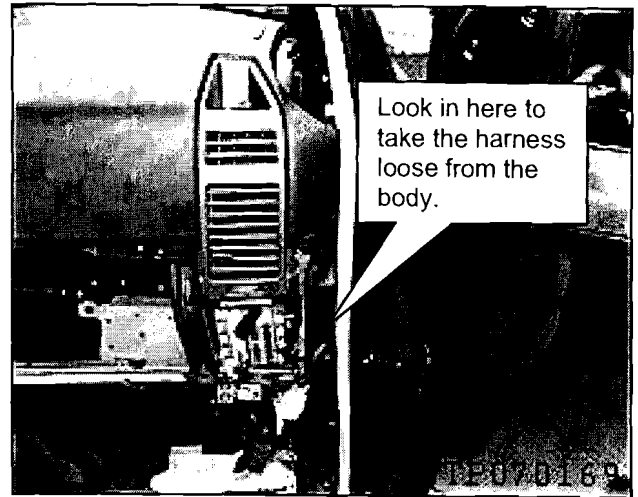

Figure D18

g. Remove the 10 side curtain air bag mounting bolts.

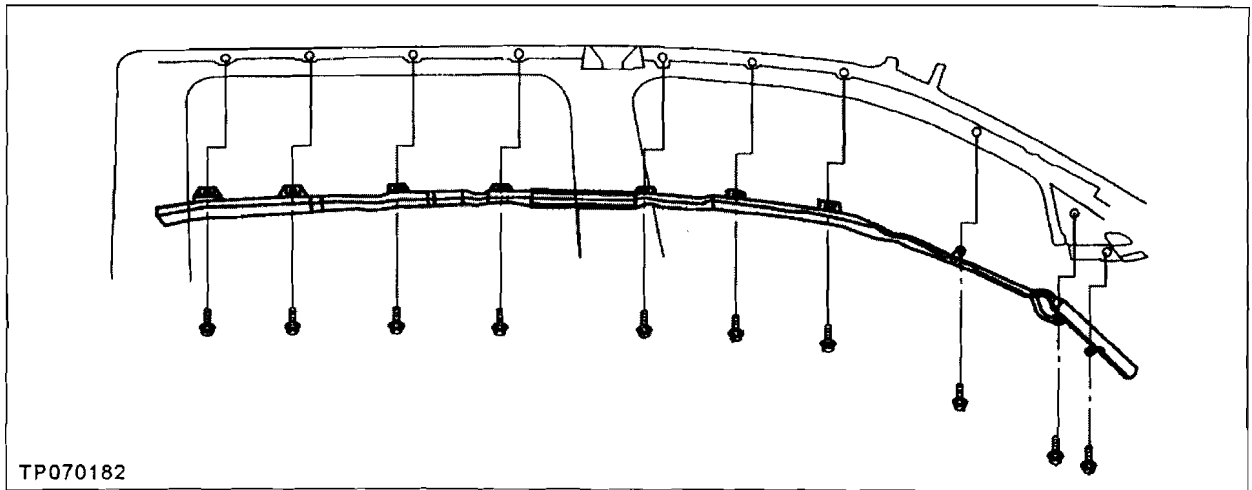

Figure D19

h. Remove the side curtain air bag module and disconnect the electrical connector.

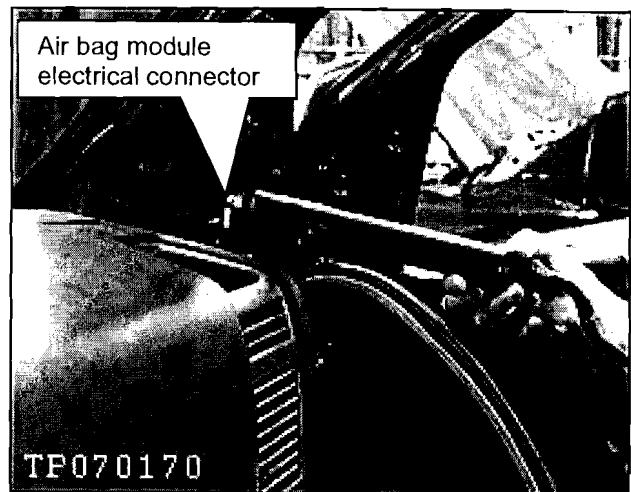

Figure D20

66. Harness should now be completely loose—remove it from the vehicle.

67. Install the new harness in reverse order. Make sure of the following:

- All harness mounting clips are installed in the correct locations.
- Seat, seat belt, and air bag bolts are tightened to correct torque:

Side curtain air bag mounting bolts	8.3 N.m (0.85 k-gm, 73 in-lb)
Front Seat Belt Anchor, Retractor, D-Ring	49 N.m (5.0 k-gm, 36 ft-lb)
Rear Seat Belt Anchor, Retractor, D-Ring	55.8 N.m (5.7 k-gm, 41 ft-lb)
Rear Seat Mounting Bolts	46.6 N.m (4.8 k-gm, 34 ft-lb)
Front Seat Mounting Bolts	45 N.m (4.6 k-gm, 33 ft-lb)

IMPORTANT:

- During installation of the new harness you will find some connectors taped to the harness as shown.
- Some of the connectors will be for options that the vehicle you are working on does not have.
- Un-tape the connectors that are needed. Leave the connectors that are not needed taped to the harness.

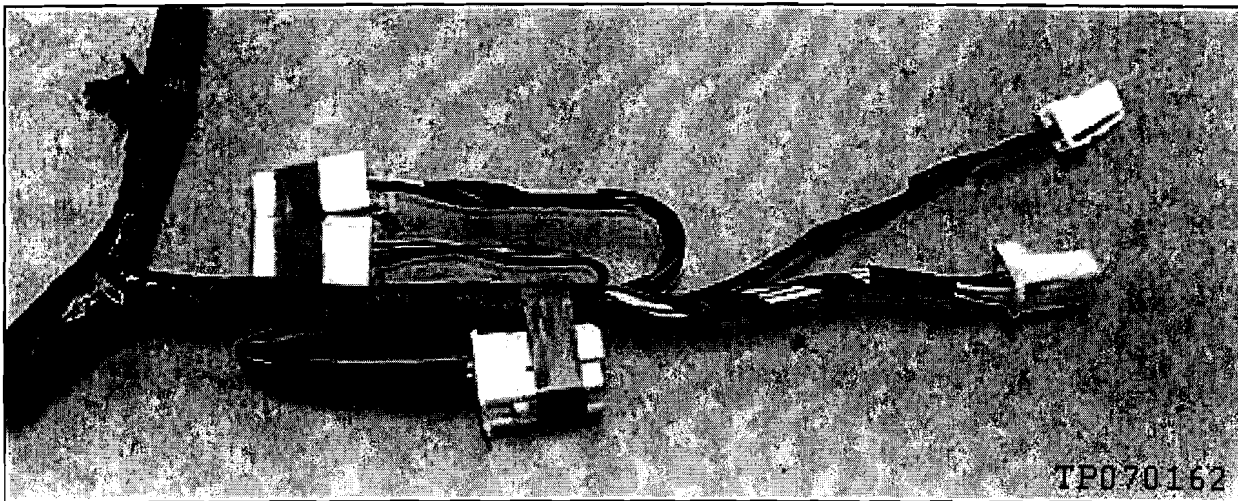

Figure D21

68. Connect both battery cables — positive cable first.

69. Reset the radio station presets.

70. If Inspection Procedure 1 was NG, or Inspection Procedure 2 result was "light stays on or blinks"; connect CONSULT-II and clear codes from the Air Bag Control Unit SELF-DIAG [PAST].

Final Quality Checks

71. Check the air bag light operation as follows:

- a. Turn the ignition OFF and then ON.
- b. Observe the air bag warning light.
- c. Make sure the air bag warning light comes on for 7 seconds and then goes out.

72. Confirm that all systems related to the harness replacement are functioning correctly.

PARTS INFORMATION

DESCRIPTION	PART NUMBER	QTY IF NEEDED
Update Kit	24009 – ZJ05A	1
Body Harness (Drivers Side) See NOTE below	Use the VIN and the electronic parts catalog (FAST or equivalent) to find the correct PIN.	1
Body Harness #2 (Passenger Side) See NOTE below		1
Front Seat Belt – Right (Passenger Side)		
Front Seat Belt – Left (Drivers Side)		1

NOTE: Order the body harness indicated in the electronic parts catalog. Your order will be automatically superseded to the appropriate campaign service harness part number. As noted in steps 45 and 67 (pages 35 and 46) campaign service harnesses have some connectors taped to the harness. Those connectors may or may not be utilized in the repair depending upon the optional equipment on the vehicle being serviced.

CLAIMS INFORMATION

Submit a Campaign (CM) line claim using the following claims coding:

"CM" I.D.: **R0616**

DESCRIPTION	OP CODE	FRT
Inspect & Install Corrugated Vinyl Tubing (Update) Kit Both Sides	R06160	0.9 hrs

OR:

DESCRIPTION	OP CODE	FRT
Inspect & Install Update Kit-Passenger Side and RPL Harness Drivers Side	R06161	2.8 hrs

OR:

DESCRIPTION	OP CODE	FRT
Inspect & Install Update Kit-Drivers Side and RPL Harness Passenger Side	R06162	3.0 hrs

OR:

DESCRIPTION	OP CODE	FRT
Inspect & RPL Both Driver Side and Passenger Side Harnesses	R06163	3.4 hrs

And, **IF** Necessary, use the following Op Codes:

DESCRIPTION	OP CODE	FRT
Additional Allowance for Center Console (if present)	R06164 (1)	0.3 hrs

(1) **R06164** allowed only when performing **R06161** or **R06162** or **R06163**

And/Or, IF Necessary

DESCRIPTION	OP CODE	FRT
Additional Allowance for SRS Curtain Airbag (if present)	R06165 (2)	0.4 hrs

(2) **R06165** allowed only when performing **R06161** or **R06162**.

And/Or, IF Necessary

DESCRIPTION	OP CODE	FRT
Additional Allowance for SRS Curtain Airbag (if present)	R06166 (3)	0.8 hrs

(3) **R06166** allowed only when performing **R06163**.

NOTE: Seat belt retractors with seat belt pretensioners should be disposed of in accordance with local and state regulations.

OWNER'S LETTER

Dear Nissan Owner:

This notice is sent to you in accordance with the requirements of the National Traffic and Motor Vehicle Safety Act. Nissan has decided that a defect that relates to motor vehicle safety exists in some 2004-2006 model year Nissan Titan King Cab vehicles. Our records indicate that you own or lease the Nissan vehicle identified by the VIN on the cover of this notice.

Reason for Recall

In some affected vehicles, there is the possibility that the wires in the harness routed through the rear doors and into the body on each side of the vehicle may break due to over bending of the harness as the doors are opened and closed. The wires in the harness control various systems including the seat belt pretensioners, the passenger side seat belt tension sensor, and rear audio speakers.

If the wire for the seat belt pretensioners breaks and makes contact with a wire for the speaker, there is a possibility that the pretensioner may deploy and tighten the seat belt. If this happens when the belt is retracted, it will not be possible to use the seat belt. Driving without the seatbelt is dangerous and could increase your risk of injury in a crash.

If one of the wires for the seat belt tension sensor breaks inside the passenger side harness, the passenger side front air bag will not deploy as designed in a frontal crash, possibly resulting in an injury.

What Nissan Will Do

Your Nissan dealer will inspect the wire harness cover for damage and, if necessary, a new wiring harness with a new type cover will be installed and rerouted. This free service should take between 2 and 5 hours to complete depending on the repair required, but your Nissan dealer may require your vehicle for a longer period of time based upon their work schedule.

What You Should Do

Contact your Nissan dealer at your earliest convenience in order to arrange an appointment to have your vehicle repaired. Please bring this notice with you when you keep your service appointment. Instructions have been sent to your Nissan dealer.

If you have paid to have your wire harness replaced prior to this campaign, you may be eligible for reimbursement of the related expense. If you have additional questions you may contact the National Consumer Affairs Department, Nissan North America, Inc., P.O. Box 685003, Franklin, TN 37068-5003. The toll free number is 1-800-NISSAN1 (1-800-647-7261). You may also contact the Administrator, National Highway Traffic Safety Administration, 400 Seventh Street, SW., Washington, DC 20590; or call the toll-free Vehicle Safety Hotline at 1-888-327-4236 (TTY: 1-800-424-9153); or go to <http://www.safercar.gov>.

Federal law requires that any vehicle lessor receiving this recall notice must forward a copy of this notice to the lessee within ten days.

Thank you for your cooperation. We are indeed sorry for any inconvenience this may cause you.
