



YAMAHA MOTOR CORPORATION, U.S.A.
6555 KATELLA AVENUE, CYPRESS, CALIFORNIA 90630-5101 714/761-7300

October 23, 2006

VIA FACSIMILE (202) 366-7882, Attn: Associate Administrator
ALSO VIA FIRST CLASS MAIL

Associate Administrator for Safety Assurance (NVS-215)
National Highway Traffic Safety Administration
400 7th Street SW
Washington, DC 20590

Regarding: 06V-397

Dear Sir/Madam,

First, we thank the Agency for their review and approval of our proposed owner's notification. Enclosed please find hard copies of the Technical Bulletin issued to our dealers as well as the approved owner's letter. All Yamaha motorcycle and scooter dealers will receive this Technical Bulletin. To facilitate repairs, dealers invoiced affected products under this recall receive an additional Bulletin with a print-out of the affected VIN's for the units they have received. The mailing of both the dealer Bulletin and owner's letter will be completed approximately on 10-30-06, so your assumption is correct as to the timing of our quarterly reports.

The determination date for this campaign was 10-3-06. The starting production period for the vehicles was November 1998, ending in April, 2001. As this campaign is international in scope we could only provide in our initial report an estimate of affected vehicles in the U.S. We are now obviously in a position to provide the accurate range. The Technical Bulletin provides the final VIN ranges by model with a combined total of 19,797 vehicles in the U.S. For TREAD purposes obviously it goes without saying similar campaigns are being conducted in other jurisdictions.

In the event I can provide further information or answer any questions please do not hesitate to contact the undersigned.

Sincerely,

A handwritten signature in black ink that reads "Russell D. Jura".

Russell D. Jura
Senior Vice President
and General Counsel

RDJ/lmf
Enclosures: Technical Bulletin
Owners Letter

Vertical stamp or text on the right side of the page, possibly a date or reference number, which is partially illegible.

Technical BULLETIN

©2006 YAMAHA MOTOR CORPORATION, USA

RECALL**This modification has top priority. This bulletin must be performed immediately to ensure customer safety.**

1999~2001 XV16 MODELS FACTORY MODIFICATION CAMPAIGN



INTRODUCTION

Yamaha Motor Corporation, U.S.A., has decided that a defect which relates to motor vehicle safety exists in 1999 and 2000, and in certain 2001 XV16 ("Road Star," and "Road Star Silverado," "Midnight Star," and "Road Star MM Limited") model motorcycles. This is an expansion of the range of affected motorcycles covered by the recalls announced in Technical Bulletin M2004-001 and M2003-011. All XV1600 motorcycles are now included in the affected range for this defect, including those prior to the range announced in M2003-011.

In affected motorcycles, certain transmission components may not meet Yamaha quality-control standards, which could allow abnormal wear that eventually results in a broken retaining circlip. If the circlip breaks, the transmission could lock up, which would also cause the rear wheel to lock up. This could result in loss of control and a vehicle crash with injury or death.

To correct this defect, Yamaha is expanding its Factory Modification Campaign. Affected motorcycles must have certain transmission components replaced with new ones. Motorcycles, outside this new range, already modified as part of the previously announced recalls do not require any additional action now.

Yamaha is notifying all registered owners of affected motorcycles by mail. A copy of this letter is included in this bulletin. The customer should take the letter along with the affected motorcycle to an authorized Yamaha dealer for the modification.

A computer report listing all affected motorcycles invoiced to your dealership is included with this bulletin. Use the list to help ensure all motorcycles are modified. All sold motorcycles that have been registered with Yamaha will show the customer's name and address. Your dealership must notify the owner of any affected motorcycle that was actually sold but is listed as "unsold" in the report.

You must modify all affected motorcycles in your inventory as well as all customer-owned motorcycles brought to you for this service. Any affected motorcycle that you purchase from Yamaha in the future will also require modification. If you purchase a motorcycle from another dealer, check to see if the procedures in this bulletin have already been performed before you sell the motorcycle.

Motorcycles that are affected should not be operated until they are modified. It is a violation of Yamaha policy for your dealership to deliver any affected motorcycles to customers until the procedures in this bulletin are performed.

When the modification on each motorcycle is performed, follow the Warranty Information section of this bulletin to receive reimbursement. Be sure to use the Factory Modification Campaign procedures in Chapter 8 of the **Warranty and Y.E.S. Handbook (LIT-11760-00-04)**.



DEALER ACTION SUMMARY

Modify: All XV16 motorcycles in the affected range.

Parts

Required: Yes. Order one 4th Pinion Gear Exchange Kit for each unit.

Warranty: Factory Modification Campaign. See the Warranty Information section of this bulletin.

Notify

Customers: Yes. You must immediately contact any customer whose motorcycle shows as unregistered on the enclosed report. Yamaha has sent letters to customers whose motorcycles were registered for warranty as of 10/20/06.



AFFECTED RANGE

1999 Models

XV16AL All
XV16ALC All
XV16ATL All
XV16ATLC All

2000 Models

XV16AM All
XV16AMC All
XV16ATM All
XV16ATMC All
XV16ASM All
XV16ASMC All

2001 Models

XV16AN VP02E-009686 ~ 012384
XV16ANC VP02Y-001007 ~ 001306
XV16ATN VP07E-004029 ~ 006068
XV16ATNC VP07Y-000453 ~ 000752

NOTE: Later production 2001 models and subsequent model years are covered by transmission recalls announced in Technical Bulletins M2003-011 or M2004-001.



SERVICE PROCEDURES

Use the XV1600 service manual (LIT-11616-12-56) for information on engine removal, disassembly, re-assembly, and installation.

The information contained in this section will give you tips or short cuts on certain procedures to help you work efficiently. For example, when disassembling the engine to access the transmission, it is not necessary to remove the camshafts, lifters, or stator assembly. Review the tips and become familiar with them before beginning work.

PREPARATION

Properly secure the motorcycle on a suitable lift. Drain the oil from the engine, reservoir tank, and transfer case. Remove the fuel tank, exhaust system, fuel system, drive system, etc. to prepare for engine removal.

Lay the components out in order of removal and keep all the fasteners separated for each component to ease re-assembly.

CAUTION:

Avoid accidental cosmetic damage. Place components such as fuel tank, side covers, and other easily damaged components in a secure and protected area. Take special care when removing and installing accessories.

TIPS

Side Cover Removal:

Before attempting to remove the right side cover, remove the left cover first to access the hidden 6mm bolt.

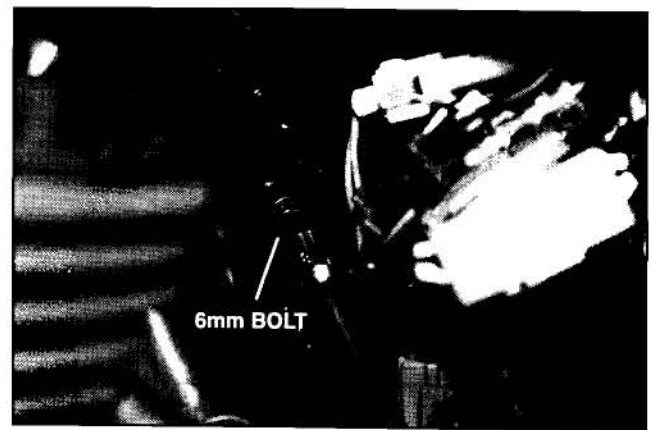
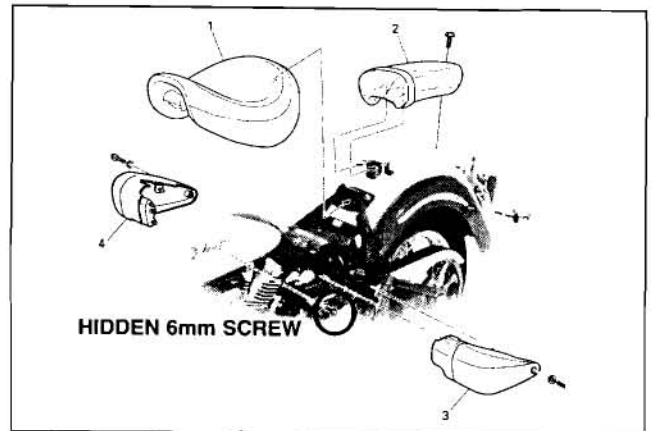

Fuel Pump and Carburetor Removal:

- Disconnect the carburetor fuel line hose at the fuel pump.
- Disconnect the fuel pump wire coupler.
- Remove the choke cable from fuel pump bracket.
- Remove the upper engine mount, leaving the fuel pump attached to the mount.
- Disconnect the TPS and carburetor wire couplers. Disconnect the throttle cables, and then remove the carburetor.

NOTE: The idle adjuster can be removed from its bracket without loosening the bracket screws.

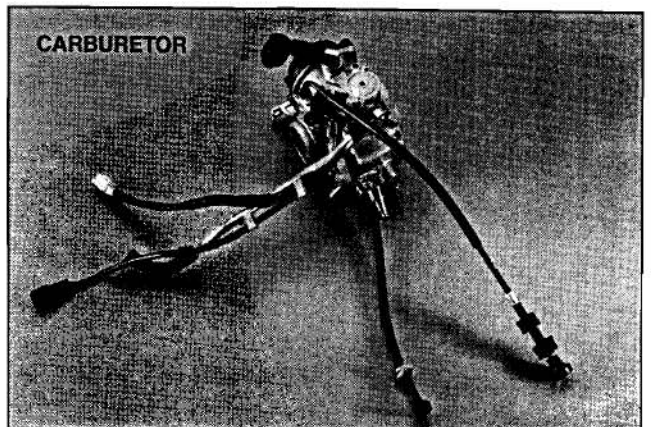

Right-Hand Footrest Removal:

- Disconnect and remove the brake light switch.
- Remove the forward-most tie wrap around the brake hose and frame.
- Remove the footrest assembly.

NOTE: Leave the brake hose attached. Move the hose to the underside of the foot rest mount and support it as necessary so that it is out of the way

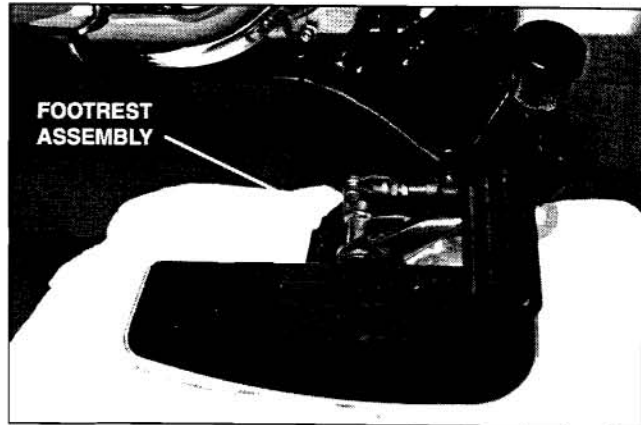

Cylinder Head Oil Pipe Removal/ Installation:

- Slightly loosen all three banjo bolts before removing them to prevent oil line deformation.

NOTE: When loosening the upper banjo bolts, hold the line in place using a wrench at the flat surface on the fitting.



Air Injection System (AIS) Removal:

- Remove the electric starter motor.
- Remove the regulator/rectifier assembly. Remove the AIS pipes from the cylinder head, but leave them attached to the AIS assembly.
- Remove the three screws with 8mm heads, and then remove the AIS air filter from the right side.
- Remove the three Phillips head screws holding the AIS assembly on the frame.
- Remove the AIS assembly from the left side.

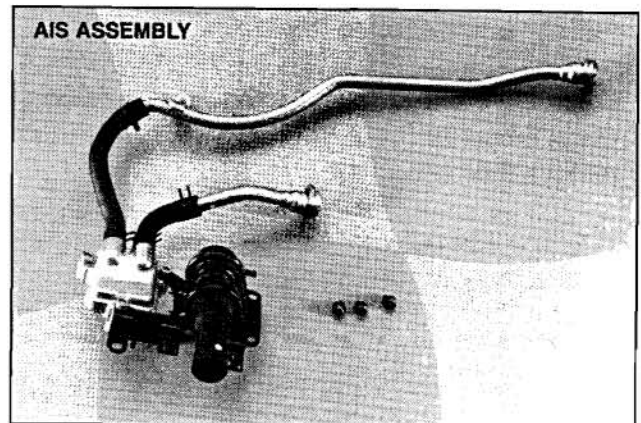
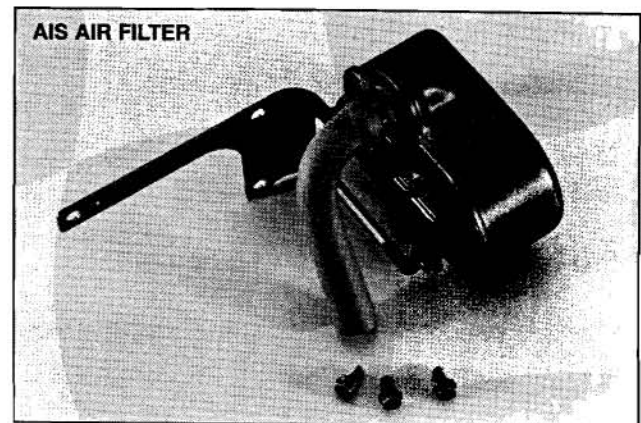

Transfer Case Removal:

- Remove the transfer case bracket first. Then remove the outer chrome cover, inner cover, and drive-sprocket nut.

NOTE: There is a sealing washer between the inner case and the transfer case at the 8mm stud. Be sure to replace it during re-assembly.

- Remove the two chrome oil lines between the engine and oil tank.

NOTE: Retain the four O-rings for re-use.

- Remove the drive pulley cover and remove the drive pulley nut.
- Loosen the drive belt tension.
- Remove the drive pulley, inner cover, collar, and O-ring.

NOTE: The collar has a bevel on its inside diameter for the O-ring facing inward and a bevel on the outside diameter facing the pulley.

- Remove the drive and driven sprockets with chain as an assembly.
- Remove the collar and O-ring.

NOTE: Collar has a bevel on its inside diameter that faces inward for the O-ring.

- Remove oil tank filler neck.
- Remove the relay bracket on the right-hand side.

NOTE: Leave the relays connected. Simply move them out of the way to allow room for transfer case removal.

- Slide the transfer case out from the right side.

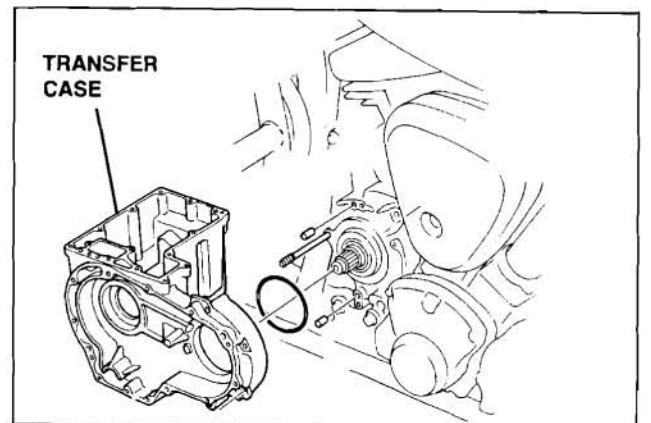
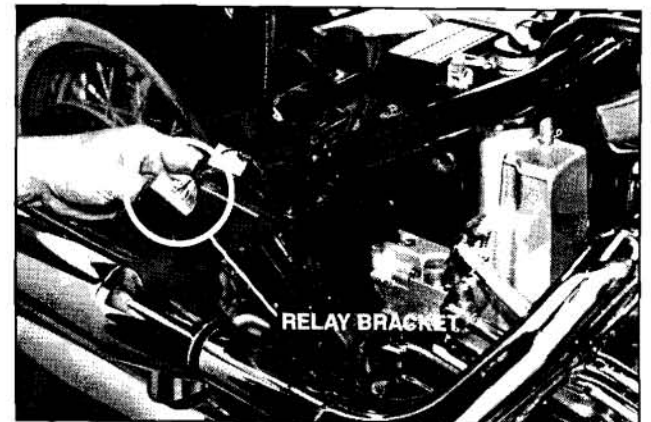
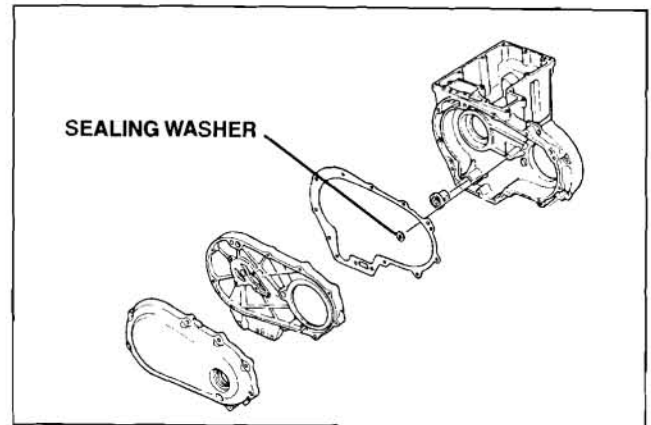

Engine Removal/Installation:

- When the engine is ready to be removed from the frame, be sure to disconnect all wire connectors and remove the oil filter bracket.
- Remove all engine mounting bolts and brackets.
- Protect all right side frame tubes with protective tape or an equivalent to prevent scratches.
- Insert steel rods in front and rear engine mount holes and with one person on each side of the engine lift the engine up and out to the right.

NOTE: Use 7/16" (10mm) steel rod at least 20" long. The steel rods used to compress the rear suspension of ATVs in their shipping crate work well.

Engine Tear Down:

Place the engine on a work bench or work surface covered with cardboard or other protective material to protect the engine finish.

- Remove the left-hand generator shaft end cover and remove the generator shaft bolt and washer.
- Remove the clutch, primary drive gear, shift shaft, shift detent, oil pump gear and oil crossover pipe.

NOTE: The right side of the crossover pipe has an O-ring. If the O-ring doesn't come out with the crossover pipe, be sure to remove it while the engine is disassembled.

- Remove both top ends.

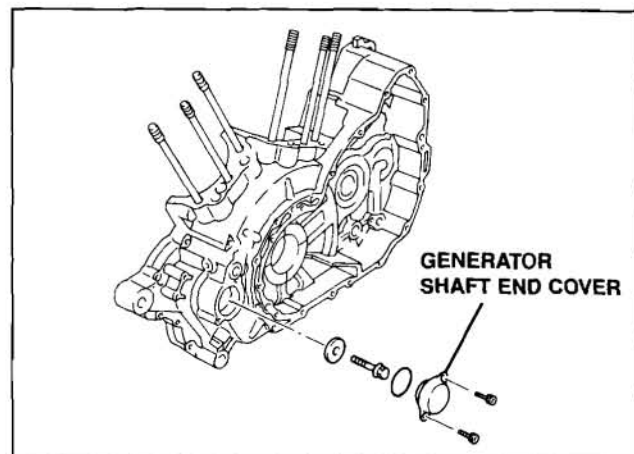
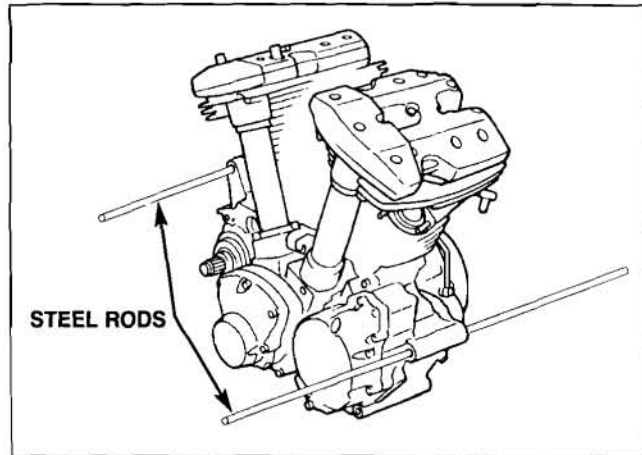

NOTE: Do not remove the push rod tubes from the crankcase. Remove only one circlip from the piston for quicker piston pin removal.

- Remove the right side crankcase bolts (three 8mm and three 6mm) only.

NOTE: Do not remove the cam cover or generator cover.

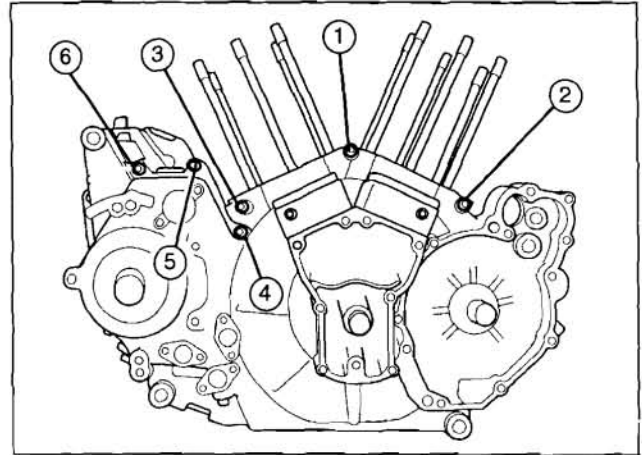

- Tilt the engine to the right and rest the cam cover against a block covered with cardboard or other protective material to protect the engine finish. Remove the left-side crankcase bolts (6mm bolts, quantity 15).
- Align the shift cam segment with the segment-shaped hole in the crankcase.
- While holding the crankshaft against the right crankcase, remove the left crankcase half.

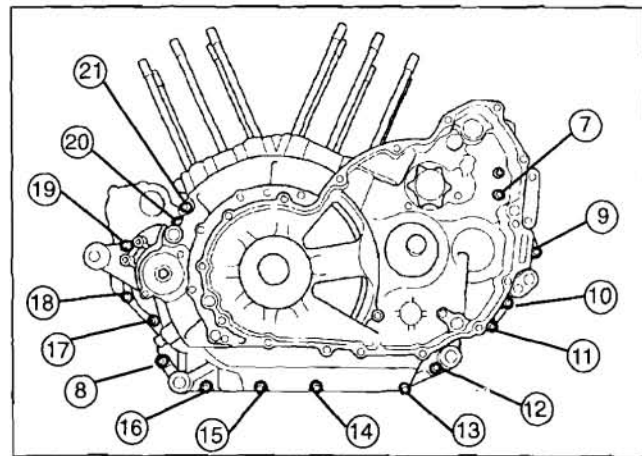

CAUTION:

Be sure to hold the crankshaft against the right case half to prevent disengagement of the camshaft drive gear.

- Remove the shift fork shafts, shift forks, and transmission.

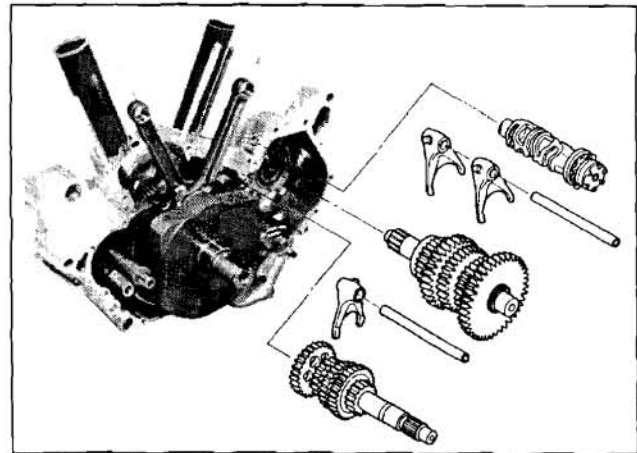

Main Shaft Modification:

- Completely disassemble the main shaft. The Washer 7 , 5th Pinion Gear 6 , and 2nd/3rd Pinion Gear 5 will be reused.
- Install the components on the new-type Main Shaft 9 in the following order. Lubricate all components with engine oil. Be sure circlips are installed with the sharp edge of the inner diameter facing away from the mating washer.

- 1 Collar – NEW
- 2 4th Pinion Gear – NEW
- 3 Washer – NEW
- 4 Circlip – NEW
- 5 2nd/3rd Pinion Gear – Reuse original part
- 6 5th Pinion Gear – Reuse original part
- 7 Washer – Reuse original part
- 8 Circlip – NEW

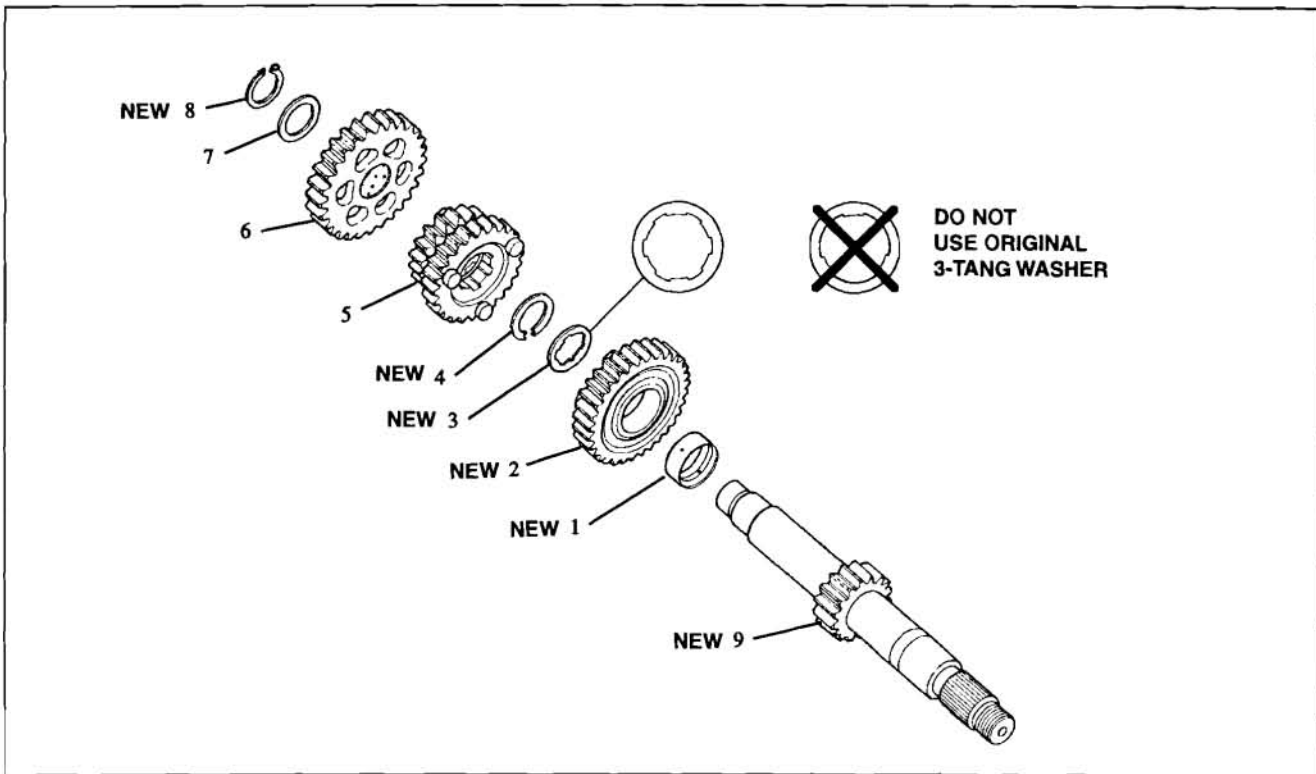

⚠ WARNING

Be sure to use all of the new parts in the kit. Otherwise, the transmission can still fail. Be sure that you are installing the new washer 3 . It is thicker than the original and can be easily identified by its six tangs on the inner diameter instead of the three on the original washer.

Drive Shaft Modification:

- Remove the circlip and washer from the Drive Shaft, then remove the 1st Wheel Gear and the 4th Wheel Gear. Do not disassemble the rest of the components on the shaft.
- Install the components on the original Drive Shaft in the following order. Lubricate all components with engine oil. Be sure the circlip is installed with the sharp edge of the inner diameter facing away from the mating washer.

- 1 4th Wheel Gear – NEW
- 2 1st Wheel Gear – Reuse original part
- 3 Washer – Reuse original part
- 4 Circlip – NEW

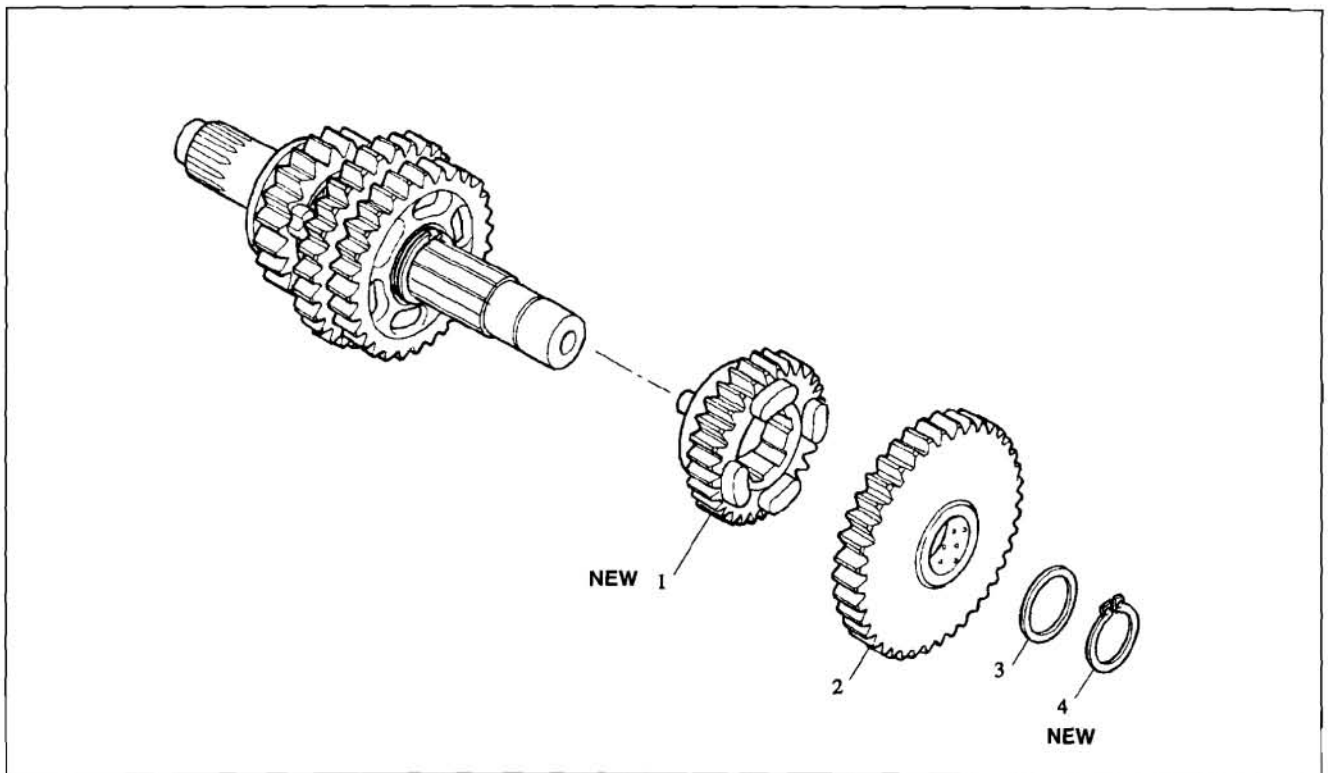

⚠ WARNING

Be sure to use all of the new parts in the kit. Otherwise, the transmission can still fail.

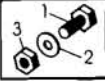

PARTS INFORMATION

Part Number	Description	Qty	Dealer Cost
90891-10117-00	4th Pinion Gear Exchange Kit	1	\$79.49
	• Axle, Main (4WM-17411-A0-00)	• 1	
	• Gear, 4th Pinion (5VN-17141-00-00)	• 1	
	• Collar (90387-281T8-00)	• 1	
	• Washer (90209-25013-00)	• 1	
	• Circlip (93410-23056-00)	• 1	
	• Circlip (93440-28062-00)	• 1	
	• Gear, 4th Wheel (4NK-17241-02-00)	• 1	
	• Circlip (93410-25017-00)	• 1	
	• Circlip (93450-24028-00)	• 2	
	• Piston Ring Set (34L-11610-00-00)	• 2	
	• Washer, Lock (90215-25218-00)	• 1	
	• Gasket, Crankcase Cover1 (5PX-15451-00-00)	• 1	
	• Gasket, Cyl. Head 2 (4WM-11182-00-00)	• 2	
	• Gasket, Head Cover 1 (4WM-11193-00-00)	• 2	
	• Gasket, Head Cover 2(4WM-11194-00-00)	• 2	
	• Gasket, Cyl. (4WM-11351-00-00)	• 2	
	• Gasket, Cyl. Head 1 (4WM-11181-00-00)	• 2	
	• Gasket, Exhaust Pipe (3EG-14613-00-00)	• 2	
	• Gasket, Silencer (3XW-14755-00-00)	• 2	
	• Intake Manifold O-Ring (93210-505A4-00)	• 2	
	• Gasket 1 (5PX-17929-00-00)	• 1	
	• Washer, Lock (90215-26241-00)	• 2	
	• Element Assy, Oil Cleaner (3FV-13440-10-00)	• 1	
	• O-ring (93210-06667-00)	• 1	
	• Gasket 2 (4WM-17931-00-00)	• 1	
	• Washer, Plate (90201-08087-00)	• 2	
	• Gasket (90430-10171-00)	• 4	



IDENTIFICATION PROCEDURE

After modifying a unit, make a punch mark above the frame number (VIN) on the steering head pipe as shown in the illustration below.

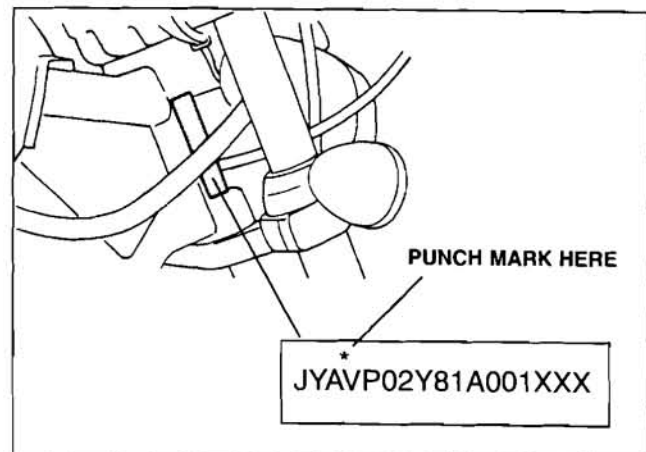



WARRANTY INFORMATION

The owner of each warranty-registered affected unit will receive a letter announcing this campaign. The letter has a label that includes the Primary ID and Recall Number. Use this information when submitting for reimbursement as described below.

The modification is authorized for all affected motorcycles, both sold and unsold, regardless of ownership or warranty status. You do not need the customer's letter to perform the modification or to file for reimbursement.

Submit a Recall Request for the transmission replacement as described below using Recall Number **990035**. Choose the status "M." You will be reimbursed a labor allowance of **9.0** hours, which includes a reimbursement amount for oil and other shop supplies, plus the cost of the 4th Pinion Gear Exchange Kit and your handling fee.

YDS:

When signed on to YDS, click on the Service Tab, and then "Recall Request-Add." This function has recently been improved to allow you to enter multiple Primary IDs for the same recall. Remember that YDS now requires a 7-digit serial number, so use a "0" as the first digit. The system will check your submission instantly to make sure the Primary ID numbers you've entered are valid for the recall. You can check back the next day for your claim numbers to track your credit.

MAIL:

Complete a recall Reimbursement Request (LIT-11790-00-03) as shown below:

Dealer Number:							Dealer Name:														
9 9 0 0 3 5							V P 0 2 E - 0 0 0 9 X X X							1 0 - 2 5 - 2 0 0 6						M I	
																				M I	
																				M I	
																				M I	

If you have any questions about proper procedures for Factory Modification Campaigns, see Chapter 8 in your Warranty and Y.E.S. Handbook (LIT-11760-00-04).



YAMAHA

CUSTOMER SUPPORT GROUP

6555 Katella Avenue, Cypress, California 90630-5101 (714) 761-7300

SAFETY RECALL NOTICE

October 24, 2006

Dear Yamaha Owner:

This notice is sent to you in accordance with the requirements of the National Traffic and Motor Vehicle Safety Act. Yamaha Motor Corporation, U.S.A., has decided that a defect which relates to motor vehicle safety exists in 1999 and 2000, and in certain 2001 XV16 ("Road Star," and "Road Star Silverado," "Midnight Star," and "Road Star MM Limited") model motorcycles. Our records show that you own the affected motorcycle shown on the label above.

The reason for this recall:

In affected motorcycles, certain transmission components may not meet Yamaha quality-control standards, which could allow abnormal wear that eventually results in a broken retaining circlip. If the circlip breaks, the transmission could lock up, which would also cause the rear wheel to lock up. This could result in loss of control and a vehicle crash with injury or death.

What Yamaha and your dealer will do:

To correct this defect, your authorized Yamaha dealer will replace certain transmission components with new ones. There will be no charge to you for this procedure. Your dealer will probably need to keep your motorcycle for at least two days to accomplish the required modification.

What you should do now:

Please call your Yamaha dealer to make a service appointment to have this procedure performed. At that same time, you can find out how long he expects he will need to keep your motorcycle for this service. Remember to take this letter with you when you take in your motorcycle.

You should not ride your motorcycle until this modification is performed.

If you are unable to return to the Yamaha dealer who sold you the motorcycle, this service will be performed by any authorized Yamaha Motorcycle dealer. For the name of a dealer near you, call 1-800-88-YAMAHA or visit the Yamaha web site at: www.yamaha-motor.com.

Federal regulations require that any vehicle lessor receiving this recall notice must forward a copy of this notice to the lessee within 10 days.

If you need help:

If, after contacting your dealership, you have questions or concerns which the dealership is unable to answer, please write to:

Yamaha Motor Corporation, U.S.A.
Customer Relations Department
P.O. Box 6555
Cypress CA 90630

If, after contacting Yamaha Customer Relations, you are still not satisfied that we have done our best to remedy the situation without charge and within a reasonable time, you may submit a written complaint to the Administrator, National Highway Traffic Safety Administration, 400 Seventh Street, SW., Washington, DC 20590; or call the Auto Safety Hotline at 1-888-327-4236 (TTY: 1-800-424-9153); or go to <http://www.safercar.gov>.

If you no longer own this Yamaha:

If you have sold your motorcycle to another party, please call us toll-free at 1-800-227-5963 with the name and address of the new owner, along with the serial number shown above your name on the address label above.

We're sorry to cause you any inconvenience, but we are sincerely concerned about your safety and continued satisfaction with our products. Thank you for giving your attention to this important matter.

Sincerely,
Customer Support Group
Yamaha Motor Corporation, U.S.A.