

**DEALER NOTIFICATION LETTER  
SAFETY RECALL AMG R0601  
STEERING GEAR ATTACHMENT**

November 2006

Dear HUMMER Dealer:

Enclosed herewith you will find information about Safety Recall AMG R0601, Steering Gear Attachment Hardware. Please review this material carefully. Owners have been instructed to contact you to arrange for an appointment.

Twenty five 2006 model year HUMMER® H1 vehicles built between April 22, 2005 and May 26, 2005 may have been assembled with incorrect steering gear attaching hardware. This condition could result in steering gear loosening and possible separation from the vehicle's frame. Complete loss of vehicle steering would occur in the event of gear separation from the frame.

To ensure minimum customer confusion on this matter, your cooperation is requested. **PLEASE DO NOT** make unsolicited contact with Owners informing them of this campaign. All the vehicles involved with this condition have been identified and owners are being individually contacted to bring their vehicles in for inspection and repair if necessary.

If you have any questions regarding this request or the enclosed material, please contact our Warranty Department at 1-800-638-8303.

Customer Satisfaction Department  
AM General LLC

Enclosures.



## PRODUCT RECALL BULLETIN

Subject: PRODUCT RECALL AMG R0601 STEERING GEAR ATTACHMENT

Models Affected: MODEL YEAR 2006 ALPHA VEHICLES WITH VIN

137PH84306E220571	137PH90346E221024	137PH84316E221034
137PH90326E221054	137PH84386E221063	137PH84376E221104
137PH90316E221112	137PH84356E221120	137PH84346E221156
137PH90386E221205	137PH90326E221233	137PH843X6E221243
137PH84326E221253	137PH90326E221264	137PH903X6E221304
137PH90326E221314	137PH90356E221324	137PH84326E221334
137PH84356E221344	137PH90356E221355	137PH84376E221376
137PH84316E221406	137PH903X6E221416	137PH84376E221426
137PH90386E221446		

### SERVICE INFORMATION

Twenty five 2006 model year HUMMER H1 vehicles built between April 22, 2005 and May 26, 2005 may have been assembled with incorrect steering gear attachment hardware. This condition could result in steering gear loosening and possible separation from the vehicle's frame. Complete loss of steering would occur in the event of separation from the frame.

### OWNER NOTIFICATION

Owners of affected HUMMERS will be contacted and requested to make arrangements with a local dealer for campaign service. Campaign service inspections will be performed at no cost to the owner. A copy of the Owner's Notification Letter is included with this bulletin.

**Important: Some involved vehicles may be in Dealer Inventory (new or used), or in use as demonstrator models. If so, these vehicles must have the campaign service completed before retail delivery.**

### SERVICE REPAIR AND REQUIRED COMPONENTS

Service repair will require inspection of the steering gear attachment hardware and a possible replacement of the steering gear and hardware.

### PARTS

Replacement Steering Gear Kits can be ordered through the DCS under PN 5746278.

### WARRANTY

The provisions of the normal vehicle warranty policy apply.

### TIME

The time required to inspect the steering gear hardware configuration and check the torque is 0.6 hour. Labor operation 060801, warranty type J, complaint code R0601, malfunction code 86.

The time required to inspect the hardware configuration, change the steering gear and hardware and apply the proper torque is 2.5 hour. Labor operation 060802, warranty type J, complaint code R0601, malfunction code 86.

## PROCEDURE

### Inspection And Torque

1. Perform a visual inspection of the hardware attaching the steering gear to the frame. The **upper bolt** requires a spacer and a split lock washer (See Figure 1). Both **lower bolts** use only a flat washer and a split lock washer.
2. If the spacer and washers are in the correct positions, apply 175 lb-ft. (237 N·m) of torque to all three bolts.
3. If any of the bolts rotate before the torque value is attained, remove all the bolts and clean all thread locking compound from the gear and the bolts.
4. Apply Loctite 242, or equivalent medium strength thread locker to the threads, place the spacer and washers on the bolts in the positions shown below and torque the bolts to 175 lb-ft. (237 N·m).

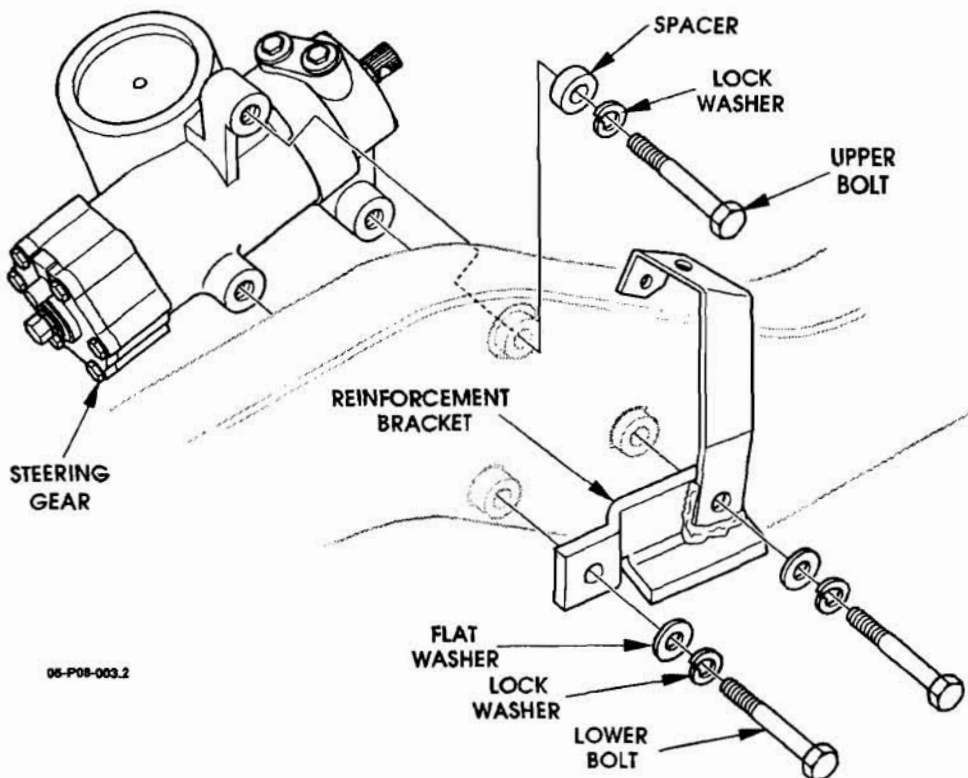

Figure 1: Steering Gear Attachment Hardware

### Steering Gear And Hardware Replacement

1. If the spacer and washers are not in the correct positions, replace the steering gear and hardware (See Service Manual Section 8). Torque the bolts to 175 lb-ft (237 N·m).

**CUSTOMER NOTIFICATION LETTER  
SAFETY RECALL AMG R0601  
STEERING GEAR ATTACHMENT**

November 2006

**Dear HUMMER Owner:**

This notice is being sent to you in accordance with requirements of the National Highway Traffic and Motor Vehicle Safety Act. AM General has decided that a defect which relates to motor vehicle safety exists in 2006 model year HUMMER H1 vehicles built between April 22, 2005 and May 26, 2005.

**The problem is ...** Vehicles were assembled with an incorrect combination of steering-gear-to-frame attachment hardware. This condition may result in steering gear loosening and separation from the frame. If this happens, there will be a complete loss of vehicle steering which could result in a crash.

**What your HUMMER Dealer will do ...** Your dealer will inspect, and correct if necessary, your vehicle for the proper steering gear hardware assembly. This procedure will be performed at **NO COST** to you.

**What you must do ...** Contact your HUMMER Dealer immediately to schedule an appointment for this important service. **REFERENCE NUMBER AMG R0601.**

**If you need help ...** If you have trouble getting your vehicle inspected, please call AM General at 1-800-638-8303. If you believe that AM General or your authorized HUMMER Dealer has failed or is unable to remedy the problem without charge or within reasonable time, you may submit a written complaint to: The Administrator, National Highway Traffic Safety Administration, 400 Seventh Street, SW., Washington, D.C. 20590; or call the toll-free Vehicle Safety Hotline at 1-888-327-4236 (TTY: 1-800-424-9153); or go to <http://www.safercar.gov>.

We are sorry for any inconvenience to you, but your safety and continued satisfaction with your HUMMER are important to us. Your cooperation is appreciated.

Customer Satisfaction Department  
AM General LLC