



RECALL CAMPAIGN BULLETIN

Reference:
NTB06-083

Date:
November 10, 2006

VOLUNTARY RECALL CAMPAIGN 2007 VERSA; BRAKE FLUID RESERVOIR CAP

CAMPAIGN I.D. / NHTSA # PB024 / 06V-348
APPLIED VEHICLE: 2007 Versa (C11)
APPLIED VINS: 3N1BC13E(*)7L 350001 - 369667

INTRODUCTION

Nissan has determined that the brake fluid reservoir cap on some 2007 model year Versa vehicle fails to comply with Federal Motor Vehicle Safety Standard (FMVSS) No. 135 "Light Vehicle Brake Systems." The standard specifies, among other things, certain brake fluid reservoir labeling requirements.

The wording embossed on the brake fluid reservoir cap is incorrect and does not contain the statement "WARNING CLEAN FILLER CAP BEFORE REMOVING. USE ONLY DOT3 BRAKE FLUID FROM A SEALED CONTAINER." as required by FMVSS No. 135. To correct this condition, Nissan is conducting a Voluntary Recall Campaign to replace the existing brake fluid reservoir cap with a new brake fluid reservoir cap containing the required labeling.

The customer will be sent a new brake fluid reservoir cap including instructions on how to replace the cap themselves. If the customer prefers, they can choose to bring their vehicle with the new cap sent to them to a Nissan dealer for installation at no charge.

IDENTIFICATION NUMBER

Nissan has assigned identification number PB024 to this campaign. This number must appear on all communications and documentation of any nature dealing with this Campaign.

NUMBER OF VEHICLES POTENTIALLY AFFECTED

The number of vehicles potentially affected is approximately 13,184.

2007 JAN 23 P 2:32
RECEIVED

DEALER RESPONSIBILITY

Federal law requires that new vehicles in dealer inventory which are the subject of a safety recall must be corrected prior to sale. Failure to do so can result in civil penalties by the National Highway Traffic Safety Administration. While federal law applies only to new vehicles, Nissan strongly encourages dealers to correct any used vehicles in their inventory before they are retailed.

Instructions For Versa Brake Fluid Reservoir Cap Installation

CAUTION:

- Make sure the engine is off and the vehicle is in park with the parking brake applied.
- Don't let dirt fall into the brake fluid reservoir.
- Don't get brake fluid on painted surfaces. This will damage the paint. If fluid is spilled, immediately wash the surface with water.

NOTE: The brake fluid reservoir is located under the hood behind the battery.

1. Use a clean cloth to wipe clean the brake reservoir cap and the area around it.
2. Turn the cap counter-clockwise to remove it.
3. Install the new cap. Turn it clockwise until it stops.

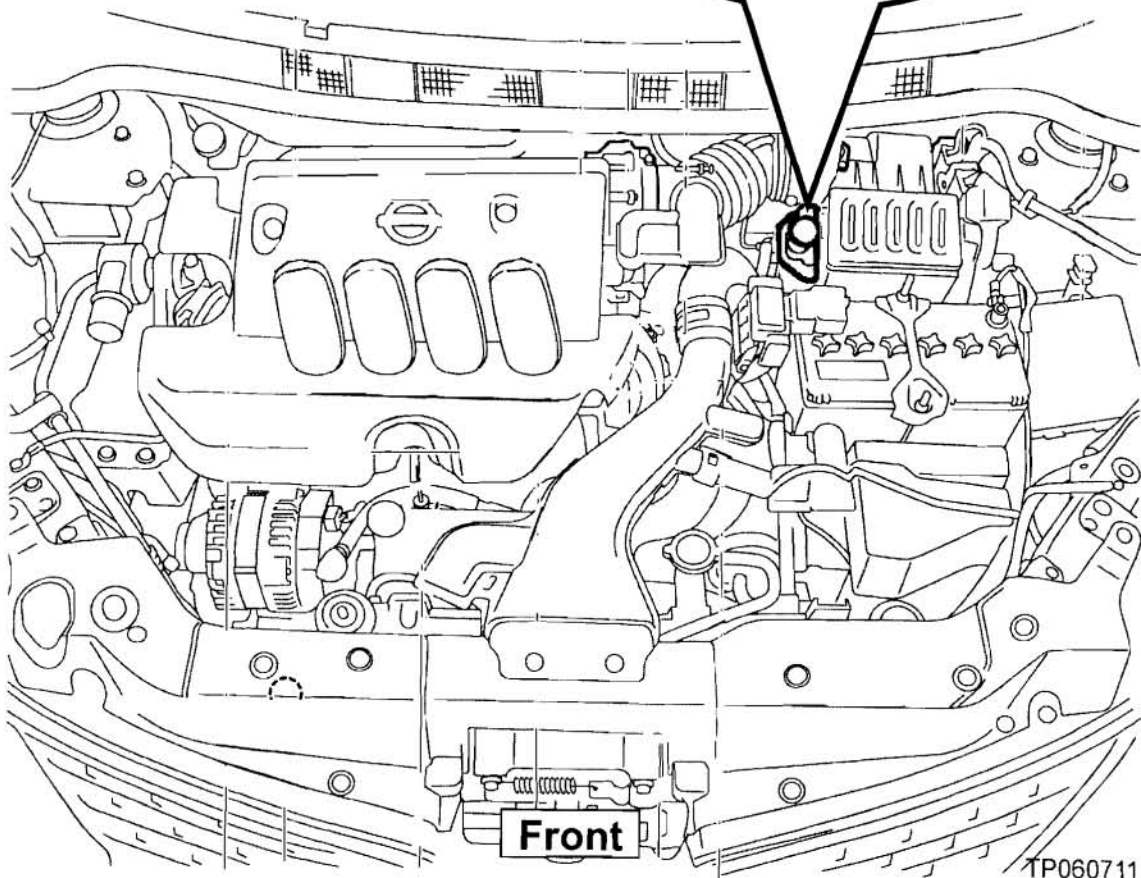
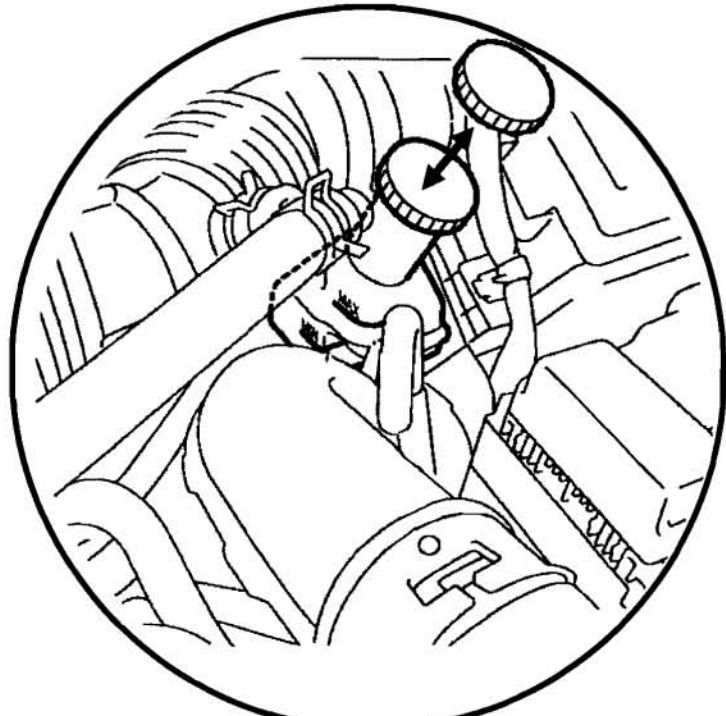

PARTS INFORMATION

| DESCRIPTION | PART # | QTY |
|--|---------------|-----|
| Cap Assy – Oil Reservoir Tank (Brake Fluid Reservoir Cap) | 46020 – EM30A | 1 |

CLAIMS INFORMATION

Submit a Campaign (CM) line claim using the following claims coding:

“CM” I.D.: PB024

| DESCRIPTION | OP CODE | FRT |
|-------------------------------|---------|-----|
| RPL Brake Fluid Reservoir Cap | PB0240 | 0.2 |

OWNER'S LETTER

Dear Nissan owner:

This notice is sent to you in accordance with the requirements of the National Traffic and Motor Vehicle Safety Act. Nissan has determined that the brake fluid reservoir cap on your 2007 model year Versa vehicle fails to comply with Federal Motor Vehicle Safety Standard (FMVSS) No. 135 "Light Vehicle Brake Systems." The standard specifies, among other things, certain brake fluid reservoir labeling requirements.

Reason for Recall

The wording embossed on the brake fluid reservoir cap does not contain the statement "CLEAN FILLER CAP BEFORE REMOVING," as required by FMVSS No. 135. Failure to clean the brake fluid reservoir cap could lead to brake fluid contamination if there is dirt or debris on the cap. Brake fluid contamination could result in a decrease or loss of brake function.

What Nissan Will Do

Provided with this notification is a new brake fluid reservoir cap containing the required labeling. Also included are instructions for the installation of your new brake fluid reservoir cap.

What You Should Do

Please replace the brake fluid reservoir on your vehicle with the one included with this notice. Installation instructions are provided. If you prefer, contact your Nissan dealer and make an appointment to have the new cap installed at **no charge** to you. Please bring this notice and replacement cap with you to the service appointment. If the dealer fails, or is unable to make the necessary repairs free of charge, you may contact the National Consumer Affairs Department, Nissan North America, Inc., P.O. Box 685003, Franklin, TN 37068-5003. The toll free number is 1-800-NISSAN1 (1-800-647-7261). You may also contact the Administrator, National Highway Traffic Safety Administration, 400 Seventh Street, SW., Washington, DC 20590; or call the toll-free Vehicle Safety Hotline at 1-888-327-4236 (TTY: 1-800-424-9153); or go to <http://www.safercar.gov>.

Federal law requires that any vehicle lessor receiving this recall notice must forward a copy of this notice to the lessee within ten days.

Thank you for your cooperation. We are indeed sorry for any inconvenience this may cause you.

