

# ***SERVICE PROCEDURE***

G-06506-R1

July 2006

**SUBJECT: SAFETY RECALL (U.S., EXPORT)  
SR-7™ SPRING BRAKE MODULATING VALVE on  
certain 4000 and 7000 Models built 4/6/2006 thru  
6/9/2006**

## **REVISION DESCRIPTION (SEPTEMBER 2007)**

### **PARTS INFORMATION**

- Part changed to **8900205R91**.

### **SERVICE PROCEDURE**

- Added **NOTE**.

### **LABOR INFORMATION**

- Removed labor operation A40-06506-2.
- Added SPECIAL INSTRUCTIONS – Inspection only.
- Added SPECIAL INSTRUCTIONS - Valve Replacement.
- Added labor operation A40-07511-5.

## **DEFECT DESCRIPTION**

An internal check valve in the Bendix® SR-7™ Spring Brake Modulating Valve may not properly seat, causing internal air leakage. This internal leakage can cause a delay in the application of the spring brakes to park the vehicle after the operator pulls the dash valve button. A delay in the application of the spring brakes can contribute to a vehicle roll away. A vehicle roll away may cause a **vehicle crash**, possibly resulting in **property damage, personal injury, or death**.

## **MODELS INVOLVED**

This Safety Recall involves 4000 and 7000 6X4 and 6X6 *TRUCK* models and 4000 and 7000 *TRACTORS* with feature code 04WDT -- *SPRING BRAKE MODULATOR VALVE With Relay Function* built 4/6/2006 thru 6/9/2006.

## **PARTS INFORMATION**

The parts required for this recall are:

<b>Part Number</b>	<b>Part Description</b>	<b>Quantity</b>
<b>8900205R91</b>	KIT, BRK SPRING VLV SR-7 FIELD	<b>1</b>

## **SERVICE PROCEDURE**



**WARNING:**

*TO PREVENT SERIOUS EYE INJURY, ALWAYS WEAR SAFE EYE PROTECTION WHEN YOU PERFORM VEHICLE MAINTENANCE OR SERVICE.*



**WARNING:**

*TO PREVENT UNEXPECTED MOVEMENT OF THE VEHICLE AND POSSIBLE SERIOUS PERSONAL INJURY OR DEATH, BLOCK THE WHEELS TO PREVENT THE VEHICLE FROM MOVING IN BOTH DIRECTIONS.*

**NOTE:** For all vehicles involved in this Safety Recall having the service procedure performed AFTER 9/14/2007, please follow the special instructions in the LABOR INFORMATION SECTION.

### **BENDIX INSTRUCTION SHEET**

Please refer to the attached Bendix Instruction sheet for the proper inspection and valve replacement procedure.

## **END OF SERVICE PROCEDURE**

## LABOR INFORMATION

**DISREGARD THE LABOR REIMBURSEMENT PORTION OF THE BENDIX INSTRUCTION SHEET. DO NOT FILE THE BENDIX FORM 2586. USE THE LABOR OPERATIONS LISTED BELOW IN INTERNATIONAL'S STANDARD WARRANTY SYSTEM.**

### ***SPECIAL INSTRUCTIONS – Inspection Only:***

Any vehicle having this service procedure performed AFTER 9/14/2007 **where the inspection DOES NOT require valve replacement**, please file the following labor operation:

<u>Operation No.</u>	<u>Description</u>	<u>Time</u>
A40-06506-1	<i>Inspect Valve for suspect date code</i>	0.5 hr

***Then continue on to perform Safety Recall G-07511 and install the cartridge assembly.***

### ***SPECIAL INSTRUCTIONS – Valve Replacement:***

Any vehicle having this service procedure performed AFTER 9/14/2007 **where the inspection requires valve replacement**, please file the following additional labor operation:

<u>Operation No.</u>	<u>Description</u>	<u>Time</u>
A40-07511-5	<b><i>ADD ON, for replacement of suspect valve</i></b>	0.5 hr

All vehicles will require the inspection. On vehicles where the inspection requires valve replacement, please file BOTH labor operations.

## CAMPAIGN IDENTIFICATION LABEL

*Each vehicle corrected in accordance with this campaign **must be** marked with a CTS-1075 Campaign Identification Label.*

Complete the label and attach on a clean surface next to the vehicle identification number (VIN) plate.

<b>DO NOT REMOVE</b>
<b>INTERNATIONAL</b>
Campaign No.
VIN
Eng.#
<b>COMPLETED</b>
Service Location Code #
<b>DO NOT REMOVE</b>

## **ADMINISTRATIVE/DEALER RESPONSIBILITIES (U.S. & POSSESSIONS)**

Proceed immediately to make necessary correction to units in inventory. **All inventory vehicles subject to this recall campaign must be corrected prior to sale, transfer or delivery.** If vehicles have been sold or transferred and you are in receipt of Customer Notification Letters and Authorization for Recall Service cards for those vehicles, the transfer location or customer must be notified **IMMEDIATELY** from your dealer location.

Dealers must correct all vehicles subject to this campaign at no charge to the owner, regardless of mileage, age of vehicle, or ownership, from this time forward.

The National Traffic and Motor Vehicle Safety Act, as amended, provides that each vehicle that is subject to a vehicle recall campaign must be adequately **repaired** within a reasonable time after the owner has tendered it for repair. A failure to adequately repair within **60 days** after a tender of a vehicle is prima facie evidence of failure to repair within a reasonable time. If the condition is not adequately repaired within 60 days, the owner may be entitled to **replacement** with an identical or reasonable equivalent vehicle at no charge, or to a **refund** of the purchase price less a reasonable allowance for depreciation.

However, consistent with the customer notification, dealers are expected to complete the repairs on the mutually agreed upon service date.

To avoid having to replace an owner vehicle or refund the purchase price, every effort must be made to promptly schedule an appointment with each owner to repair his or her vehicle as soon as possible.

During the recall process, a listing of owner names and addresses will be furnished to the involved dealers to enable dealers to follow up with owners and have the vehicles corrected. You must limit the use of this listing to this campaign because the list may contain information obtained from state motor vehicle registration records and the use of such motor vehicle registration data for purposes other than this campaign is a violation of law in several states.

## WARRANTY CLAIMS

Refer to Dealer Warranty Manual for procedures to conduct Recall Campaigns.

It is important that the Recall Coding be completed properly to assist in processing the warranty claim. Complete instructions will be found in the Warranty Manual, Section 7-1. Special attention should be given to Items 39 through 44:

	GROUP	NOUN	C	WARR.	TP	PAD
GROUP Enter number G—						
NOUN Leave blank						
C (CAUSE) Enter either 1, 2, 3. (see below)						
1. Inspected (No repair required).						
2. Inspected and repaired.						
3. Defective part from parts stock.						
WARRANTY (Warranty Code) Enter 40.						
TYPE PART Enter P for type part causing failure.						
PAD Enter 100						

## ADMINISTRATIVE/DISTRIBUTOR RESPONSIBILITY (EXPORT)

Proceed immediately to make necessary correction to units in inventory. All inventory vehicles subject to this recall campaign must be corrected prior to sale, transfer or delivery. If vehicles have been sold or transferred and you are in receipt of Customer Notification Letters and Authorization for Recall Service cards for those vehicles, the transfer location or customer must be notified from your distributor location.

Export locations are to submit warranty claims in the usual manner making reference to this recall number.

We ask for your full cooperation and follow-up to this important subject matter. If you have any questions or need further assistance, please contact the Regional Service Manager at your regional office.

## **INTERNATIONAL TRUCK AND ENGINE CORPORATION**



# Installation Instructions

BENDIX® SR-7™ SPRING BRAKE MODULATING VALVE INSTALLATION

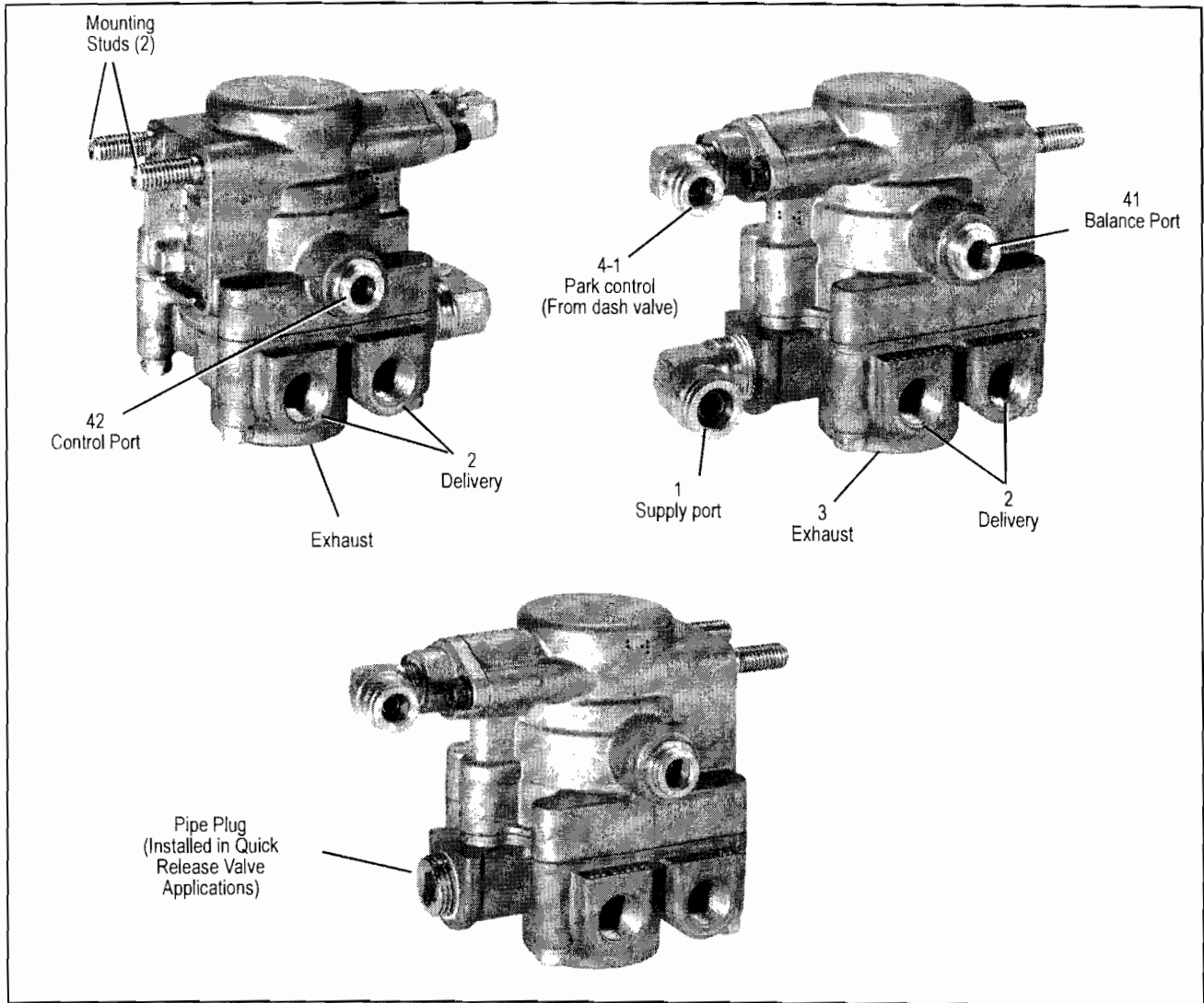

Figure 1 - BENDIX® SR-7™ SPRING BRAKE MODULATING VALVE PORT DESIGNATIONS

## GENERAL

This instruction sheet is intended to provide the necessary information to replace the Bendix® SR-7™ spring brake modulating valve in connection with recall campaign number 06E051.

**Before installing this valve, verify that the valve being replaced qualifies for the SR-7™ recall campaign.**

## GENERAL SAFETY GUIDELINES

**WARNING! PLEASE READ AND FOLLOW THESE INSTRUCTIONS TO AVOID PERSONAL INJURY OR DEATH:**

When working on or around a vehicle, the following general precautions should be observed at all times.

1. Park the vehicle on a level surface, apply the parking brakes, and always block the wheels. Always wear safety glasses.
2. Stop the engine and remove ignition key when working under or around the vehicle. When working

in the engine compartment, the engine should be shut off and the ignition key should be removed. Where circumstances require that the engine be in operation, EXTREME CAUTION should be used to prevent personal injury resulting from contact with moving, rotating, leaking, heated or electrically charged components.

3. Do not attempt to install, remove, disassemble or assemble a component until you have read and thoroughly understand the recommended procedures. Use only the proper tools and observe all precautions pertaining to use of those tools.
4. If the work is being performed on the vehicle's air brake system, or any auxiliary pressurized air systems, make certain to drain the air pressure from all reservoirs before beginning ANY work on the vehicle. If the vehicle is equipped with an AD-IS® air dryer system or a dryer reservoir module, be sure to drain the purge reservoir.
5. Following the vehicle manufacturer's recommended procedures, deactivate the electrical system in a manner that safely removes all electrical power from the vehicle.
6. Never exceed manufacturer's recommended pressures.
7. Never connect or disconnect a hose or line containing pressure; it may whip. Never remove a component or plug unless you are certain all system pressure has been depleted.
8. Use only genuine Bendix® replacement parts, components and kits. Replacement hardware, tubing, hose, fittings, etc. must be of equivalent size, type and strength as original equipment and be designed specifically for such applications and systems.
9. Components with stripped threads or damaged parts should be replaced rather than repaired. Do not attempt repairs requiring machining or welding unless specifically stated and approved by the vehicle and component manufacturer.
10. Prior to returning the vehicle to service, make certain all components and systems are restored to their proper operating condition.
11. For vehicles with Antilock Traction Control (ATC), the ATC function must be disabled (ATC indicator lamp should be ON) prior to performing any vehicle maintenance where one or more wheels on a drive axle are lifted off the ground and moving.

#### VALVE IDENTIFICATION

Refer to Figure 2 for valve identification.

1. Locate the SR-7™ valve on the vehicle. Typically it is located near the rear axle mounted on the frame rail.
2. On the mounting stud side of the valve look for "Bendix" cast into the valve body. If the valve needs to be removed to properly see this portion of the body, remove per the Valve Removal section of this document.

3. If the casting has "Bendix 2" on the side, it is not affected by the recall campaign and no further action is required.
4. If the casting has "Bendix 1" on the side, it is potentially affected by the recall campaign and must be further identified.
5. To further identify the valve, locate the manufacture date code on the top of the valve. Vehicle paint may need to be removed to identify the date code. SR-7™ valves with the casting code "Bendix 1" manufactured between April 1, 2006 and May 24, 2006 are subject to the recall campaign and must be replaced. Interpret the manufacturing date code to identify if the valve is subject to the recall.

#### Manufacturing Date Code Interpretation:

The key date code characters used for identification are the 2<sup>nd</sup> through the 6<sup>th</sup> alphanumeric characters; all others can be disregarded.

The second character in the date code is an alpha character representing the month of manufacture (A through M skipping the letter I) corresponding to January through December (D = April and E = May). The next four characters are numbers representing the two digit day of the month followed by the two digit year. For example the date code 1C0706T, key characters C0706, indicates the valve was manufactured 30706 or March 7, 2006.

6. If the valve date code does not fall within the dates of April 1, 2006 (D0106) and May 24, 2006 (E2406) inclusive, then no further action is needed.
7. **If the SR-7™ valve has a casting code "Bendix 1" and was manufactured between April 1, 2006 and May 24, 2006 it is subject to the recall campaign and must be replaced.**

#### VALVE REMOVAL

1. Prior to removing the SR-7™ valve, review the general safety guidelines of this document.
2. Identify all air lines before disconnecting.
3. Remove the two mounting nuts that secure the valve to the frame rail and remove the valve.
4. Compare the valve that was removed to the replacement valve. If the valve that was removed contains fittings or pipe plugs that the new valve does not, note their orientation and remove the fittings.
5. Using pipe sealant, install the fittings that were removed into the replacement SR-7™ valve. Be sure that orientation of the fittings is the same. Teflon tape is not an acceptable substitute for pipe sealant. Install fittings finger tight, then tighten 1.5 - 2 turns. For shaped fittings, such as tees and elbows, tighten no more than one additional turn to the final position.

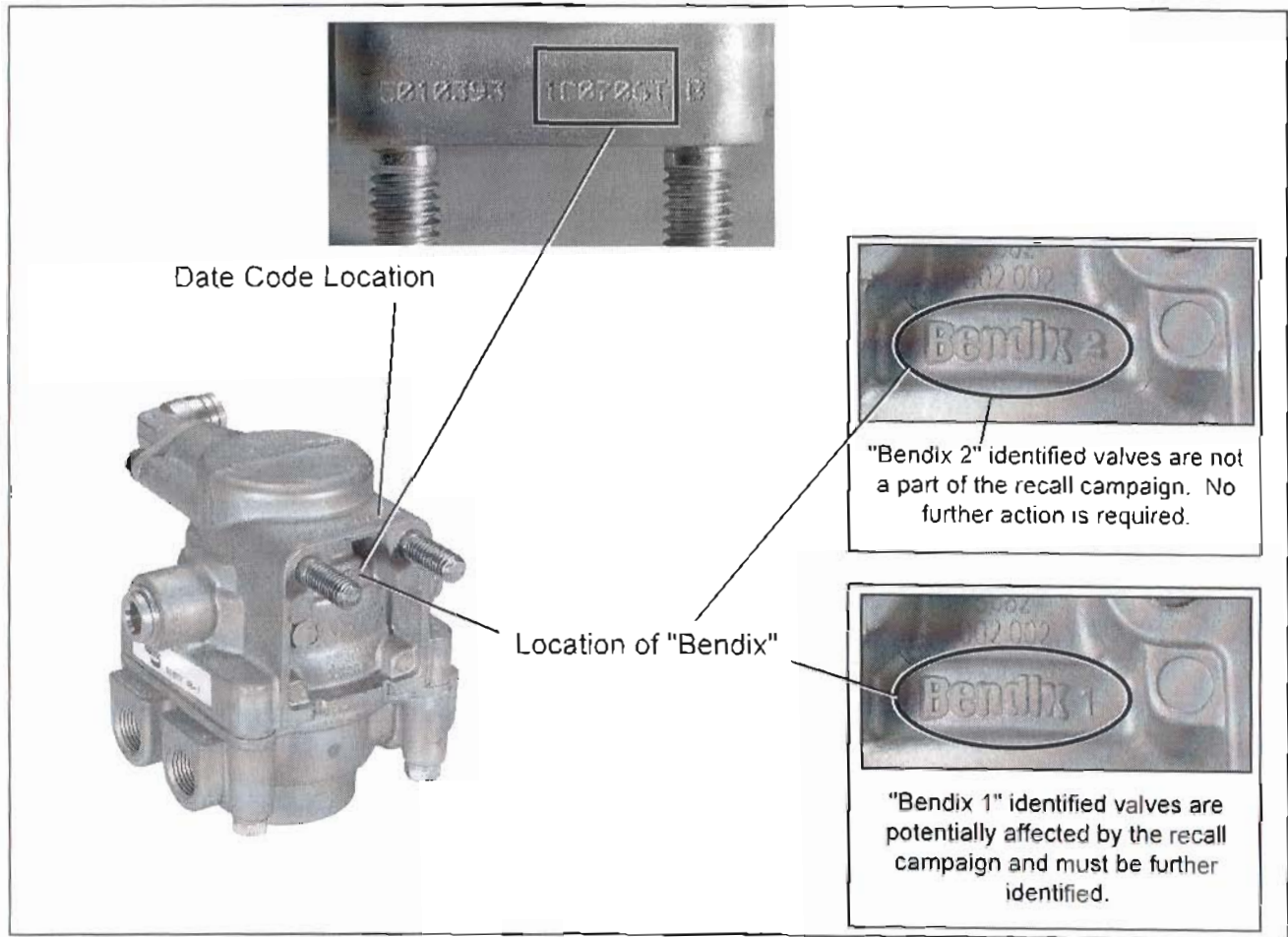

Figure 2 - LOCATION OF IDENTIFICATION CODES

- If a single check valve is located in the supply port of the SR-7™ valve being removed, it must be removed and installed on the replacement valve. A standard fitting is **not** an acceptable substitute.

#### VALVE INSTALLATION

- Align the valve mounting studs with the mounting holes on the vehicle frame rail. Tighten the mounting nuts to 180-220 in. lbs.
- Install the valve onto the vehicle ensuring all air lines are connected as marked during disassembly.

#### TESTING THE REPLACEMENT SR-7™ SPRING BRAKE MODULATING VALVE

Perform operating and leakage tests as outlined in "Operating Tests" section.

#### LEAKAGE TEST

Place the park control valve in the "release" position; using a soap solution, coat all ports including the exhaust port. A 1" bubble in 3 seconds is permitted (175 SCCM).

If the valve does not function as described, or if leakage is excessive, it is recommended that it be replaced with

a new unit available from a Bendix parts outlet. **DO NOT ATTEMPT TO DISASSEMBLE THE SR-7™ VALVE. THE VALVE CONTAINS HIGH SPRING FORCES THAT COULD RESULT IN PERSONAL INJURY IF DISASSEMBLY IS ATTEMPTED!**

#### OPERATING TEST

Block vehicle and hold by means other than vehicle brakes. Charge air brake system to governor cut-out pressure.

Place parking control valve in "park" position. Observe that spring brake actuators apply promptly, within 3 seconds. Place parking control valve in "release" position. Observe that spring brake actuators release fully.

Once the system is functioning normally, the field repair is considered complete.

#### LABOR REIMBURSEMENT

Complete and submit the labor reimbursement form, BW2586.