

**GM SERVICE AND PARTS OPERATIONS
DCS1662
URGENT - DISTRIBUTE IMMEDIATELY**

Date: October 12, 2006

Subject: 06041 – Product Safety Recall
Body-Color Roof Adhesive Separation
Phase 1 Customer Mailing

Models: 2005-2006 Chevrolet Corvette With Body-Color Roof

To: All Chevrolet Dealers

Attention: Service Manager, Parts Manager and Warranty Administrator

PRODUCT FIELD ACTION ANNOUNCEMENT

DUE TO PART AVAILABILITY, CUSTOMER NOTIFICATION FOR THIS PRODUCT FIELD ACTION IS BEING ADMINISTERED IN PHASES. THE FIRST PHASE INVOLVES 14,220 VEHICLES. AS PARTS BECOME AVAILABLE, ADDITIONAL LETTERS WILL BE MAILED TO INVOLVED CUSTOMERS AND YOU WILL BE NOTIFIED VIA GM ADMINISTRATIVE MESSAGE.

General Motors is releasing Product Safety Recall 06041 today. The total number of vehicles involved is approximately 27,000 with 14,226 being released in the first phase. Please see the attached bulletin for details.

It is important to note that there are two different customer notification letters for this recall. One letter is for the general population, which includes vehicles that received a temporary roof repair as an interim remedy (labor code T5611). The other letter is for customers who had their roof panel replaced under Customer Satisfaction Program 05112 but did not have the additional adhesive applied to the new roof panel.

As each phase is released, Customer Satisfaction Program 05112 will be cancelled on vehicles involved in that phase. Vehicles that were not repaired under Customer Satisfaction Program 05112 will be transferred into this safety recall.

Any outstanding claims for Customer Satisfaction Program 05112 must be submitted for payment as soon as possible. To allow claims to process, Customer Satisfaction Program 05112 will remain open in GMVIS two weeks after the launching the phase. When you query GMVIS to determine eligibility, if Customer Satisfaction Program 05112 and Safety Recall 06041 both show as open, perform only Safety Recall 06041.

Mailing Information

Customer notification letter mailing will begin on October 19, 2006.

GM Vehicle Inquiry System (GMVIS)

GMVIS information for **Phase 1 only** is currently available.

Service Information System (SI)

Bulletin 06041 is scheduled to be available on October 13, 2006.

Campaign Initiation Detail Report (CIDR)

The CIDR for **Phase 1 only** will be available in GM DealerWorld on October 12, 2006.

**PLEASE DOUBLE CLICK ON THE ICON BELOW
THEN SINGLE CLICK ON THE LAUNCH BUTTON
TO VIEW OR PRINT THE BULLETIN**

END OF MESSAGE
GM SERVICE AND PARTS OPERATIONS



Recall Bulletin



PRODUCT SAFETY RECALL

SUBJECT: Body-Color Roof Adhesive Separation

MODELS: 2005-2006 Chevrolet Corvette
With Body-Color Roof

This recall is being administered in phases due to part availability. As parts become available, additional phases will be released and you will be notified.

As each phase is released, Customer Satisfaction Program 05112 will be cancelled on vehicles involved in that phase. Vehicles that were not repaired under Customer Satisfaction Program 05112 will be transferred into this safety recall. In addition, vehicles that had the roof replaced, and according to the repair order did not have the adhesive foam applied, will be called back for the adhesive installation. Vehicles that had the temporary roof installed (T5641) will also be called back for roof replacement.

CONDITION

General Motors has decided that a defect, which relates to motor vehicle safety, exists in **certain** 2005-2006 Chevrolet Corvette vehicles equipped with a body-color roof. Some of these vehicles have a condition in which the adhesive between the roof panel and the frame may separate. If there is a partial separation, the occupant may notice one or more symptoms, such as a snapping noise when driving over bumps, wind noise, poor roof panel fit, roof panel movement/bounce when a door or hatch is closed, or a water leak in the headliner. If there is a complete separation, the roof panel may detach from the vehicle. If this were to occur while the vehicle was being driven, it could strike a following vehicle and cause injury and property damage.

CORRECTION

Dealers are to apply adhesive foam to the roof panel to ensure the proper adhesion, or, if signs of separation are found, install a new design roof panel.

VEHICLES INVOLVED

Involved are **certain** 2005-2006 Chevrolet Corvette vehicles equipped with a body-color roof and built within these VIN breakpoints:

YEAR	DIVISION	MODEL	FROM	THROUGH
2005	Chevrolet	Corvette	55100005	55137340
2006	Chevrolet	Corvette	65100001	65131106

Important: Dealers are to confirm vehicle eligibility prior to beginning repairs by using GMVIS. Not all vehicles within the above breakpoints may be involved.

For dealers with involved vehicles, a listing with involved vehicles containing the complete vehicle identification number, customer name, and address information has been prepared and will be provided through the applicable system listed below. Dealers will not have a report available if they have no involved vehicles currently assigned.

- US dealers - GM DealerWorld Recall Information
- Canadian dealers - GMInfoNet Recall Reports
- Export dealers - sent directly to dealers

The listing may contain customer names and addresses obtained from Motor Vehicle Registration Records. The use of such motor vehicle registration data for any purpose other than follow-up necessary to complete this recall is a violation of law in several states/provinces/countries. Accordingly, you are urged to limit the use of this report to the follow-up necessary to complete this recall.

PARTS INFORMATION

Parts required to complete this recall are to be obtained from General Motors Service and Parts Operations (GMSPO). Please refer to your "involved vehicles listing" before ordering parts. Normal orders should be placed on a DRO = Daily Replenishment Order. In an emergency situation, parts should be ordered on a CSO = Customer Special Order.

Part Number	Description	Quantity/Vehicle
88861400	Adhesive Kit - Foam	2 (C06) (If Req'd) 1 (Z06) (If Req'd)
11561612	Bolt Asm (Z06)	10
19152839	Panel, RF(Paint to Match) (Z06)	1 (If Req'd)
19152840	Panel, RF Lift Off (Paint to Match) (C06 Std. Coupe)	1 (If Req'd)
10381648	Panel, HdIng Tr (C06 Std. Coupe)	1 (If Req'd)

SPECIAL TOOL

Beginning the week of February 13, 2006, each dealer was shipped a Two-Part Adhesive Applicator Gun, BO 48206 for use in Customer Satisfaction Program 05112. That gun will be required for this recall. The tool was furnished at no charge. Additional tools, if required, may be purchased by contacting SPX Kent-Moore at 1-800-468-6657.

SERVICE PROCEDURE

Z06 Vehicles

IMPORTANT INFORMATION:

Inspect the roof panel before performing the service procedure below. Determine if the roof panel is manufactured with polycarbonate or SMC material. The interior side of the roof panel is either black or white. Roof panels manufactured with polycarbonate material are black and roof panels manufactured with SMC material are white. Carefully lower the rear edge of the headliner to view the interior side of the roof panel

1. Remove the rear roof bow trim panel. Refer to the *Rear Roof Bow Trim Panel Replacement* procedure in SI.
2. Pry down on the edge of the headliner to loosen it from the vehicle roof panel.

Important: A flashlight may be required to view the interior side of the roof panel.

3. Pull the edge of the headliner down about 51 mm (2in) to view the color of the interior side of the roof panel
 - o If the roof panel is manufactured with SMC material (white), do NOT perform the service procedure below. Re-install the rear roof bow trim panel. No further action is required.
 - o If the roof panel is manufactured with polycarbonate material (black), refer to the *Roof Panel Adhesion Inspection and Foam Fill Procedure for Z06 Vehicles* procedure found in this bulletin.

Roof Panel Adhesion Inspection and Foam Fill Procedure for Z06 Vehicles

Tools Required

- BO 48206 Two-Part Applicator Gun

1. Remove the driver and passenger side sun visor and sun visor clamp. Refer to the *Sun Shade Replacement* procedure in SI.
2. Disconnect the rear view mirror electrical connector. Refer to the *Rear View Mirror Replacement* procedure in SI.
3. Remove the windshield side garnish molding. Refer to the *Windshield Side Garnish Molding Replacement* procedure in SI.

Important: The rear roof bow trim panel holds the rear of the headliner in place.

4. Remove the rear roof bow trim panel. Refer to the *Rear Roof Bow Trim Panel Replacement* procedure in SI.



1832869

5. Remove the headliner from the vehicle
 - 5.1 Ensure that the sunshade and rear view mirror electrical connectors have been disconnected.
 - 5.2 Pry down on the edge of the headliner to loosen it from the vehicle roof panel.
 - 5.3 Lower the headliner and route it through the rear hatch.
6. Remove the bolts on all four corners of the roof panel and the center rear bracket.
7. Remove the roof panel from the vehicle. Discard the 10 roof panel fasteners.



1832871

Important: Note the orientation and number of shims on the driver and passenger side of the roof panel assembly contact points and the center rear bracket.

Notice: Protect the painted surface of the roof panel from damage.

8. Place the roof panel, painted surface down, on a glass stand, bench, or other suitable area.

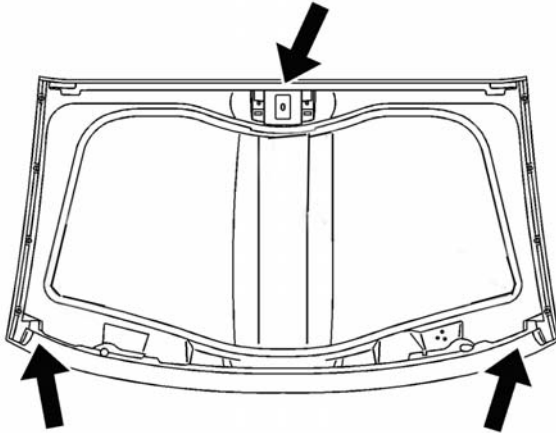

1841578

9. Inspect for proper adhesion by inserting a 0.254 mm (.010 in) feeler gage between the panel and the frame. If the feeler gage fits between the panel and the frame, and the depth is 19.05 mm (.750 in) or greater, the roof panel is separated from the frame.
 - If the feeler gage does not identify any area of the roof panel with separation, proceed to Step 10.
 - If the feeler gage identifies areas of roof panel separation, replace and paint the roof panel. Refer to Step 20.
10. Prepare the roof panel for foam adhesive injection.



1832882

Important: Use tape with strong adhesion. It is difficult to clean the foam off of visible surfaces. Ensure that the tape covers holes 1, 2, and 3.

- 10.1 Cut four pieces of tape to cover holes 1, 2, and 3. Tape length: 76 mm (3 in); Tape width: 76 mm (3 in).
- 10.2 Place the tape near the roof panel holes 1, 2, and 3. Two pieces of tape are required for roof panel hole #1.
- 10.3 Insert the two removed bolts from the rear center attachment into the holes (finger tight) until the washer is touching the roof inner panel. This is to prevent foam from filling the location where the bolts are to be when the roof is reinstalled.

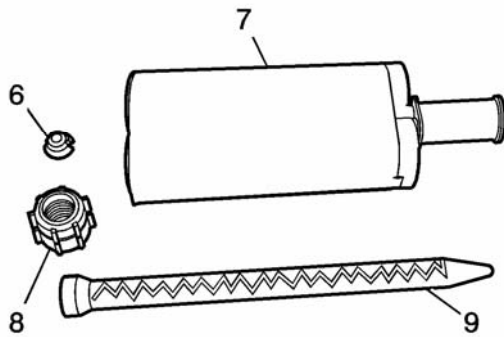

- 6 Reducer
- 7 Two-Part Foam Cartridge
- 8 Nut
- 9 Mixer Nozzle

1748413

10.4 Prepare one cartridge.

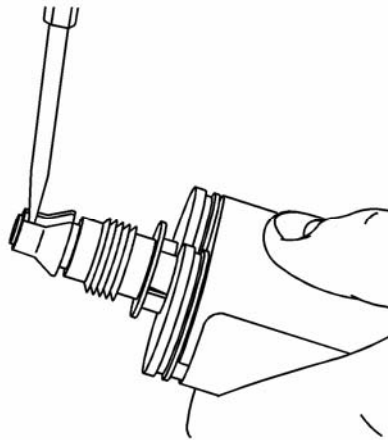

1748414

10.5 Remove the top plug. Insert a screwdriver into the end and rock it back and forth.

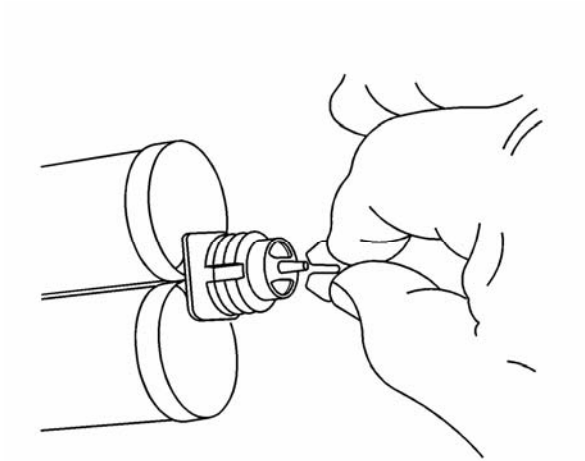

1748416

10.6 Install a reducer into the cartridge

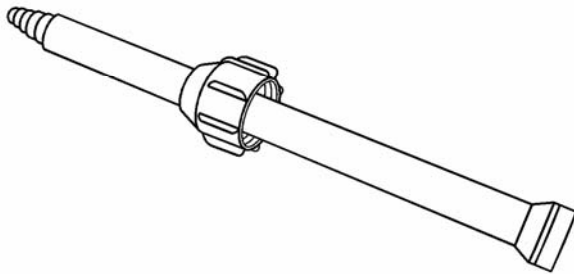

1748417

10.7 Insert a mixer nozzle through a nut.

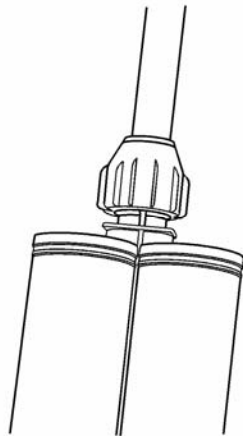

1748419

10.8 Install the nozzle onto the cartridge.

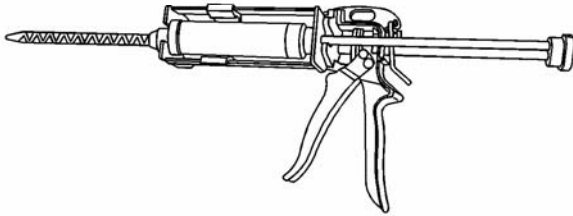

1748420

10.9 Install the cartridge nozzle assembly to the BO 48206 applicator gun.



1832882

Important: This is a two-part foam product that expands and sets very quickly. Once the mixing begins, the foam will be set in approximately 15 seconds. It is recommended that technicians wear disposable gloves while working with the foam adhesive. Steps 12, 14, and 16 must be performed within approximately 15 seconds from start to finish.

11. Place one piece of tape over the bottom (smaller) hole (1) before injecting foam into the hole (1).
12. Inject six pumps of adhesive foam into the rear slot or top hole (1) of the roof panel.
13. Tape over the top slot hole (1) to keep the foam from coming out.
14. Inject four pumps of adhesive foam into the outboard (left) side of the hole (2) and then turn the applicator to the inboard (right) side of the hole (2) and inject four pumps of adhesive foam into the hole (2).
15. Tape over the hole (2) to keep the foam from coming out.
16. Inject four pumps of adhesive foam into the outboard (left) side of the hole (3) and then turn the applicator to the inboard (right) side of the hole (3) and inject four pumps of adhesive foam into the hole (3).
17. Tape over the hole (3) to keep the foam from coming out.
18. Wait 60 seconds for the foam to set.
19. Remove the tape from holes 1, 2, and 3.

20. Look for any areas where the foam may have leaked out between the frame and the composite panel. Clean the areas where foam leaked out between the frame and the composite panel. Apply a bead of urethane to the inner and outer edge of any area of the roof panel where foam was present.
21. Inspect the roof panel bolt holes for foam or debris. Clean the bolt hole threads with a tap.



1832871

22. Install the roof panel shims to the roof panel assembly contact points. Verify the fit of the roof panel. Adjust the shims as required.

Notice: Discard the old roof panel fasteners and install new roof panel fasteners. Clean the 10 roof panel thread holes with a tap before installing the new roof panel fasteners to avoid damaging the bolt hole or fastener. This is required to clean the adhesive that was left from the original bolts on the threaded attachment holes.

23. Install the roof panel to the vehicle.

Tighten

Tighten the roof panel bolts to 9 N·m (80 lb in).



1832869

24. Install the headliner in the vehicle.

- 24.1 Slide the headliner through the rear hatch and place it into position.
- 24.2 Align the headliner in the following locations
 - Windshield side garnish moldings
 - Sun visor mounting bezel holes and sun visor clamp holes
 - Rear roof bow trim panel area
25. Connect the rear view mirror electrical connector. Refer to the *Rear View Mirror Replacement* procedure in SI.
26. Install the windshield side garnish moldings. Refer to the *Windshield Side Garnish Molding Replacement* procedure in SI.
27. Install the driver and passenger side sun visor and sun visor clamp. Refer to the *Sun Shade Replacement* procedure in SI.
28. Install the rear roof bow trim panel. Refer to the *Rear Roof Bow Trim Panel Replacement* procedure in SI.

Standard Coupe Vehicles (non Z06)

IMPORTANT INFORMATION:

Inspect the roof panel before performing the service procedure below. Determine if the roof panel is manufactured with polycarbonate or SMC material. The interior side of the roof panel is either black or white. Roof panels manufactured with polycarbonate material are black and roof panels manufactured with SMC material are white. Carefully remove an edge of the headliner to view the interior side of the roof panel.

1. Remove the roof panel from the vehicle.

Notice: Be sure to protect the painted surface of the panel from damage.

2. With the painted surface down, support the roof panel horizontally on a glass stand, bench, or other suitable area.
3. Pull the edge of the headliner back about 51 mm (2in) to view the color of the interior side of the roof panel.
 - If the roof panel is manufactured with SMC material (white), do NOT perform the service procedure below. Re-install the roof panel. No further action is required.
 - If the roof panel is manufactured with polycarbonate material (black), refer to the *Roof Panel Adhesion Inspection and Foam Fill Procedure for Standard Coupe Vehicles (non Z06)* procedure found in this bulletin.

Roof Panel Adhesion Inspection and Foam Fill Procedure for Standard Coupe Vehicles (non Z06)

Tools Required

- BO 48206 Two-Part Applicator Gun

1. Remove the roof panel from the vehicle.

Notice: Be sure to protect the painted surface of the panel from damage.

2. With the painted surface down, support the roof panel horizontally on a glass stand, bench, or other suitable area.
3. Lift the edge of the headliner in the areas indicated for inspection in the next step.

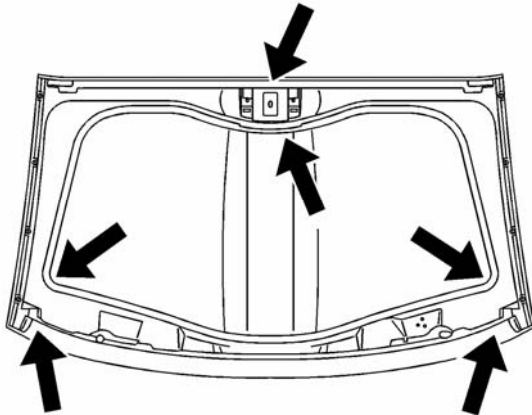

1748402

4. Inspect for proper adhesion by inserting a 0.254 mm (.010 in) feeler gage between the panel and the frame. Particular attention should be paid to the areas around the rear latch and the front corners. If the feeler gage fits between the panel and the frame, and the depth is 19.05 mm (.750 in) or greater, the roof panel is separated.
 - If the feeler gage does not identify any area of the roof panel with separation, proceed to Step 7.
 - If the feeler gage identifies areas of roof panel separation, replace the roof panel. The SI procedures below may be used.

Description	SI Document #
Headliner Replacement - Roof Lift Off Panel	1508849
Roof Lift Off Panel Rear Latch Replacement	1582986
Roof Lift Off Panel Front Latch Handle Replacement	1582355
Roof Lift Off Panel Molding Replacement	656617
Roof Lift Off Panel Rear Locator Pin Replacement	656610
Roof Lift Off Panel Adjustment	815143

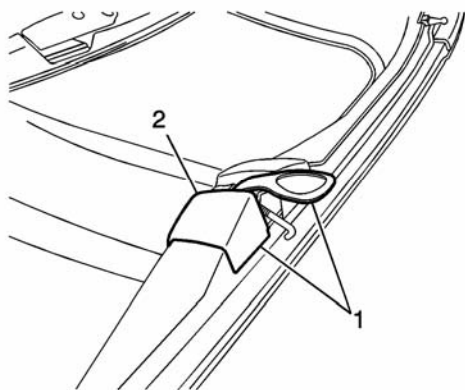

1748403

5. Remove the rear latch trim screws (1) and the trim (2).

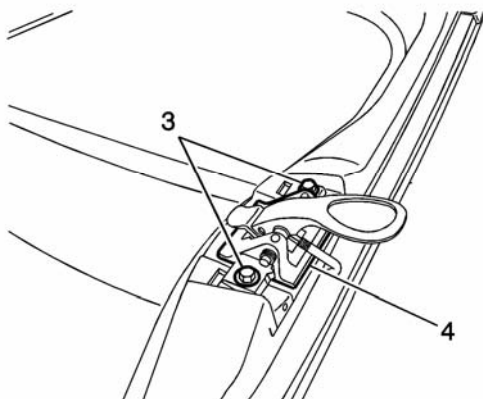

1748406

6. Remove the rear latch attaching bolts (3) and the rear latch assembly (4).
7. Install the rear latch attaching bolts (3) to the frame.

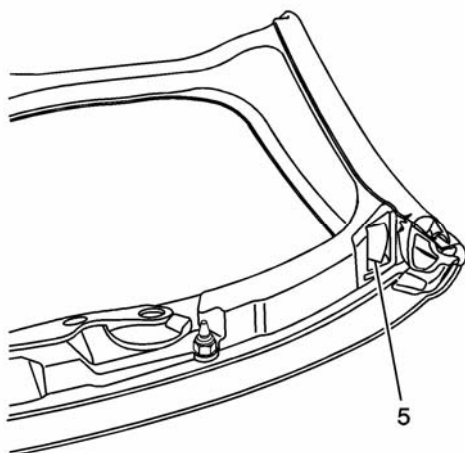

1748407

8. Remove the front corner brackets (5).

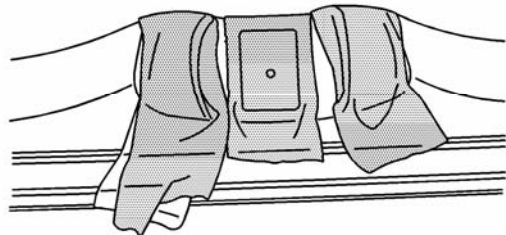

1748409

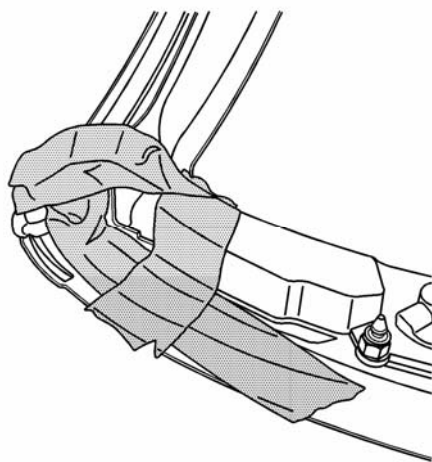

1748410

9. Tape off the rear latch and the front bracket areas.

Important: Cover the area completely with tape that has strong adhesion. It is difficult to clean the foam off of visible surfaces.

10. Using a pen or small knife, cut holes in the tape to inject foam.

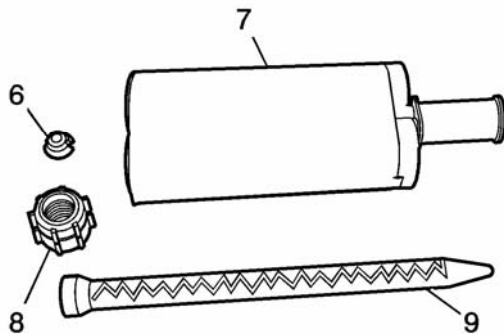

- 10 Reducer
- 11 Two-Part Foam Cartridge
- 12 Nut
- 13 Mixer Nozzle

1748413

Important: This is a two-part foam product that expands and sets very quickly. Once the mixing begins, the foam will be set in approximately 15 seconds. It is recommended that technicians wear disposable gloves while working with foam.

11. Prepare a cartridge.

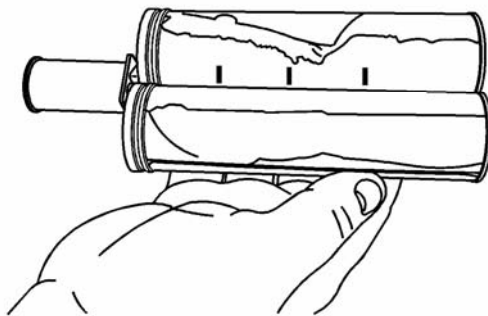

1748423

- 11.1 Remove a portion of the label.
- 11.2 Measure the length of the tubes containing the foam product. Divide the length and mark the cartridge into four equal parts.

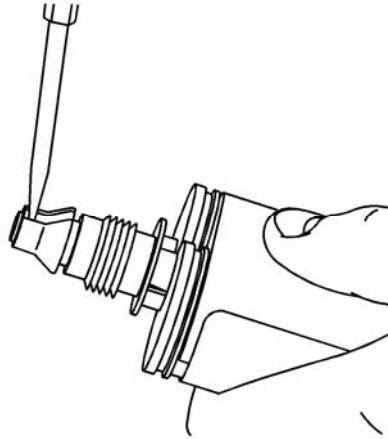

1748414

11.3 Remove the top plug. Insert a screwdriver into the end and rock it back and forth.

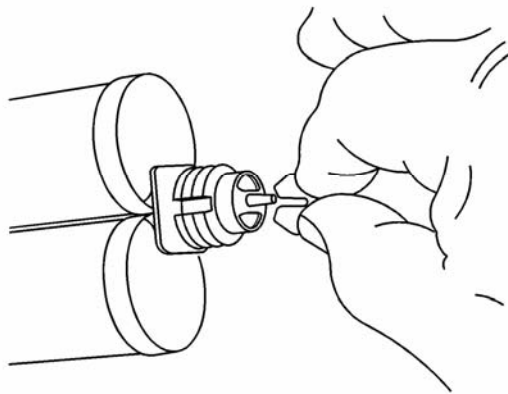

1748416

11.4 Install a reducer into the cartridge.

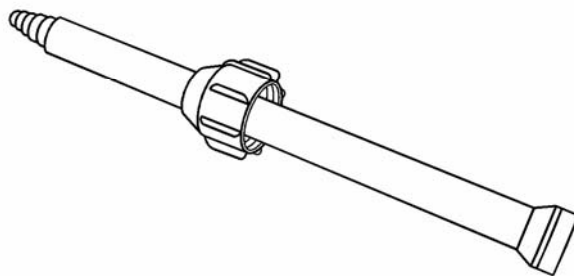

1748417

11.5 Insert a mixer nozzle through a nut.

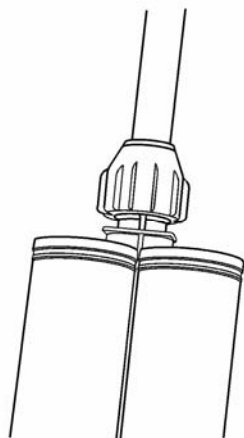

1748419

11.6 Install the nozzle onto the cartridge.

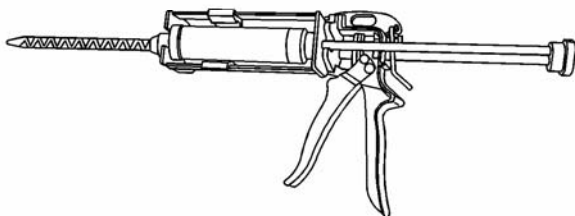

1748420

11.7 Install the cartridge nozzle assembly to the BO 48206 applicator gun.

11.8 Prepare a piece of tape to cover the hole in each front cover after the foam is injected.

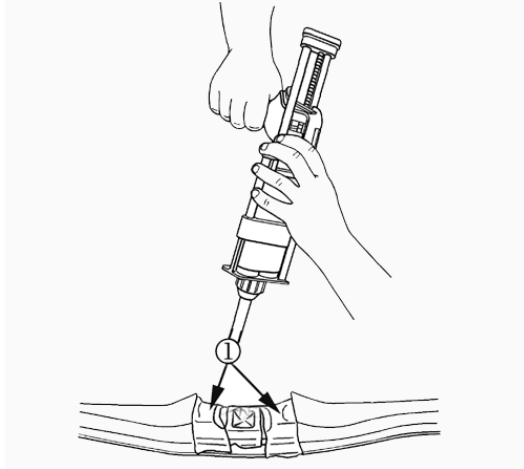

1832883

Important: The following steps must be performed within approximately 15 seconds from start to finish.

12. Inject one half of the cartridge of foam into the right rear latch area (1) of the panel and the other half of the cartridge into the left latch area (1) of the panel.
13. Tape over the holes to keep the foam from coming out.
14. Prepare a second cartridge.

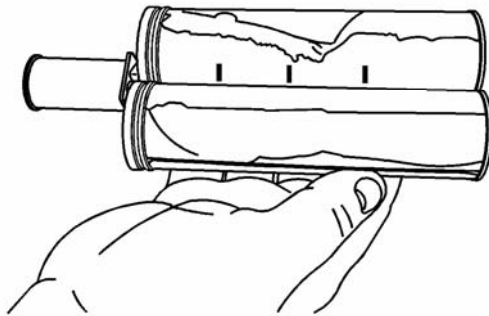

1748423

- 14.1 Remove a portion of the label.
- 14.2 Measure the length of the tubes containing the foam product. Divide the length and mark the cartridge into four equal parts.
- 14.3 Remove the top plug.
- 14.4 Install a reducer into the cartridge.
- 14.5 Insert a mixer nozzle through a nut.
- 14.6 Install the nozzle onto the cartridge.
- 14.7 Install the cartridge nozzle assembly to the BO 48206 applicator gun.
- 14.8 Prepare a piece of tape to cover the hole in each front corner after the foam is injected.

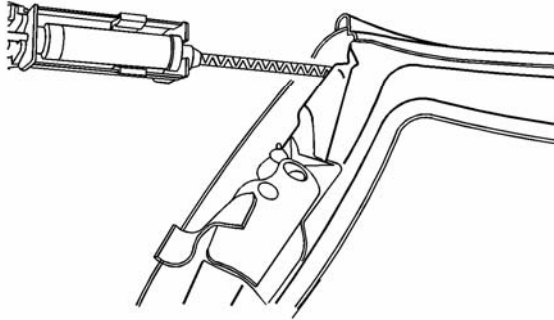

1748425

Important: The following steps must be performed within approximately 15 seconds from start to finish.

15. Insert the cartridge approximately 25 mm (1 in) into the hole.

Important: Use one quarter of the cartridge in each of the next four steps.

- 15.1 While watching the cartridge, inject one quarter of the foam in one front corner, pointing front to back.

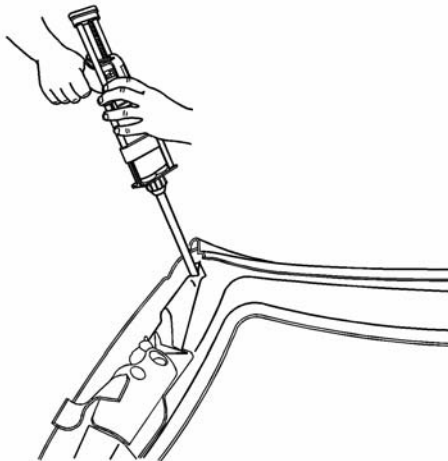

1748426

- 15.2 In the same corner, turn the applicator and inject one quarter of the foam, pointing the applicator from side to side.
- 15.3 Tape the hole closed.
- 15.4 Repeat for the other front corner.
16. Wait 60 seconds for the foam to set.
17. Remove all of the tape.
18. Look for any areas where the foam may have leaked out between the frame and the composite panel. If required, clean the area where foam leaked out between the frame and the composite panel. Apply a bead of urethane around the entire perimeter of the roof panel to improve the appearance of the roof panel edge. Apply the bead of urethane between the frame and composite panel

19. Install the front corner brackets. A sharp knife or small screwdriver may be needed to remove just enough foam to install the brackets.
20. Remove the latch bolts.
21. Install the latch and bolts. A sharp knife or small screwdriver may be needed to remove just enough foam to install the latch and latch trim cover.
22. Install the rear latch trim cover and screws.
23. Install a new headliner, if required.
24. Install the top to the vehicle.

COURTESY TRANSPORTATION – For US and Canada

The General Motors Courtesy Transportation Program is intended to minimize customer inconvenience when a vehicle requires a repair that is covered by the New Vehicle Limited Warranty. The availability of courtesy transportation to customers whose vehicles are within the warranty coverage period and involved in a product recall is very important in maintaining customer satisfaction. Dealers are to ensure that these customers understand that shuttle service or some other form of courtesy transportation is available and will be provided at no charge. Dealers should refer to the General Motors Service Policies and Procedures Manual for courtesy transportation guidelines.

CLAIM INFORMATION

Submit a Product Recall Claim with the information indicated below:

REPAIR PERFORMED	PART COUNT	PART NO.	PARTS ALLOW	CC-FC	LABOR OP	LABOR HOURS	NET ITEM
Inspect Roof – No Further Action Required (SMC Roof Already Installed)	0	N/A	N/A	MA-96	V1516	0.2	N/A
Inspect Roof & Foam Fill		---	*	MA-96	V1494		**
- Std Coupe	2					0.4	
- Z06	11					1.2	
Inspect & Replace Roof (inc 1.5 hrs for paint & mix time)		---	***	MA-96	V1495		****
- Std. Coup	1-2					1.8	
- Z06	11					2.6	
Replace Temporary Roof Installed in Cust. Sat. Program 05112 (inc 1.5 hrs for paint & mix time)	1-2	---	*****	MA-96	V1496	1.6	****
Courtesy Transportation for vehicles within the New Vehicle Limited Warranty (US & Canadian GM Dealers)	N/A	N/A	N/A	MA-96	*****	N/A	*****

- * The "Parts Allowance" should be the sum total of the current GMSP0 Dealer net price plus applicable Mark-Up or Landed Cost Mark-Up (for Export) for the two adhesive kits for the standard coupe vehicles, or one adhesive kit and 10 bolt assemblies for Z06 vehicles.
- ** The amount identified in the "Net Item" column should represent the actual sum total of the current GMSP0 Dealer net price plus applicable Mark-Up or Landed Cost Mark-Up (for Export) for the tape needed to perform the required repairs, not to exceed \$0.50 USD, \$0.58 CAD.
- *** The "Parts Allowance" should be the sum total of the current GMSP0 Dealer net price plus applicable Mark-Up or Landed Cost Mark-Up (for Export) for the roof panel, and if required, the headliner for the standard coupe vehicles, or the roof panel and 10 bolt assemblies for Z06 vehicles.
- **** The amount identified in the "Net Item" column should represent the actual sum total of the current GMSP0 Dealer net price plus applicable Mark-Up or Landed Cost Mark-Up (for Export) for the paint allowance GI (\$42.29 USD, \$48.03 CAD).
- ***** The "Parts Allowance" should be the sum total of the current GMSP0 Dealer net price plus applicable Mark-Up or Landed Cost Mark-Up (for Export) for the roof panel, and if required, the headliner for standard coupe vehicles.
- ***** Submit courtesy transportation using normal labor operations for courtesy transportation as indicated in the GM Service Policies and Procedures Manual for vehicles within the New Vehicle Limited Warranty.
- ***** The amount identified in the "Net Item" column should represent the actual dollar amount for courtesy transportation.

Refer to the General Motors WINS Claims Processing Manual for details on Product Recall Claim Submission.

CUSTOMER NOTIFICATION – For US and Canada

General Motors will notify customers of this recall on their vehicle (see copy of customer letter included with this bulletin).

CUSTOMER NOTIFICATION – For Export

Letters will be sent to known owners of record located within areas covered by the US National Traffic and Motor Vehicle Safety Act. For owners outside these areas, dealers should notify customers using the attached sample letter.

DEALER RECALL RESPONSIBILITY – For US and Export (US States, Territories, and Possessions)

The US National Traffic and Motor Vehicle Safety Act provides that each vehicle that is subject to a recall of this type must be adequately repaired within a reasonable time after the customer has tendered it for repair. A failure to repair within sixty days after tender of a vehicle is prima facie evidence of failure to repair within a reasonable time. If the condition is not adequately repaired within a reasonable time, the customer may be entitled to an identical or reasonably equivalent vehicle at no charge or to a refund of the purchase price less a reasonable allowance for depreciation. To avoid having to provide these burdensome remedies, every effort must be made to promptly schedule an appointment with each customer and to repair their vehicle as soon as possible. In the recall notification letters, customers are told how to contact the US National Highway Traffic Safety Administration if the recall is not completed within a reasonable time.

DEALER RECALL RESPONSIBILITY – All

All unsold new vehicles in dealers' possession and subject to this recall must be held and inspected/repaired per the service procedure of this recall bulletin before customers take possession of these vehicles.

Dealers are to service all vehicles subject to this recall at no charge to customers, regardless of mileage, age of vehicle, or ownership, from this time forward.

Customers who have recently purchased vehicles sold from your vehicle inventory, and for which there is no customer information indicated on the dealer listing, are to be contacted by the dealer. Arrangements are to be made to make the required correction according to the instructions contained in this bulletin. A copy of the customer letter is provided in this bulletin for your use in contacting customers. Recall follow-up cards should not be used for this purpose, since the customer may not as yet have received the notification letter.

In summary, whenever a vehicle subject to this recall enters your vehicle inventory, or is in your dealership for service in the future, you must take the steps necessary to be sure the recall correction has been made before selling or releasing the vehicle.



October 2006

Dear General Motors Customer:

This notice is sent to you in accordance with the requirements of the National Traffic and Motor Vehicle Safety Act.

General Motors has decided that a defect that relates to motor vehicle safety exists in certain 2005 and 2006 model year Chevrolet Corvette vehicles equipped with a body-color roof. As a result, GM is conducting a safety recall. We apologize for this inconvenience. However, we have taken this action for your safety and continued satisfaction with our products.

I M P O R T A N T

- Your vehicle is involved in safety recall 06041.
- Schedule an appointment with your GM dealer.
- This service will be performed for you at **no charge**.

Why is your vehicle being recalled?

Your vehicle may have a condition in which the adhesive between the roof panel and the frame may separate. If there is a partial separation, you may notice one or more symptoms, such as a snapping noise when driving over bumps, wind noise, poor roof panel fit, roof panel movement/bounce when a door or hatch is closed, or a water leak in the headliner. If there is a complete separation, the roof panel may detach from the vehicle. If this were to occur while the vehicle was being driven, it could strike a following vehicle and cause injury and property damage.

What will we do?

Your GM dealer will apply adhesive foam to ensure the proper adhesion, or, if signs of separation are found, your dealer will install a new design roof panel.

If you have already taken your vehicle to your GM dealer for this condition and the roof panel was replaced, we still need you to bring your vehicle in for an inspection.

This service will be performed for you at **no charge**. Because of service scheduling requirements, it is likely that your dealer will need your vehicle longer than the actual inspection and service correction time of approximately 25 minutes to 2½ hours, depending on the service required.

If your vehicle is within the New Vehicle Limited Warranty your dealer may provide you with shuttle service or some other form of courtesy transportation while your vehicle is at the dealership for this repair. Please refer to your Owner's Manual and your dealer for details on courtesy transportation.

What should you do?

You should contact your GM dealer to arrange a service appointment as soon as possible. Bring the enclosed customer reply form with you when you visit your dealer. The form identifies

the repairs required. If you no longer own this vehicle, please let us know by completing the form and mailing it back to us.

Do you have questions?

If you have questions or concerns that your dealer is unable to resolve, please contact the appropriate Customer Assistance Center at the number listed below. More information about this recall can be found at the Owner Center at MyGMLink, <http://www.gm.com/recall>

Division	Number	Text Telephones (TTY)
Chevrolet	1-800-630-2438	1-800-833-2438
Guam	1-671-648-8650	
Puerto Rico – English	1-800-496-9992	
Puerto Rico – Español	1-800-496-9993	
Virgin Islands	1-800-496-9994	

If after contacting your dealer and the Customer Assistance Center, you are still not satisfied we have done our best to remedy this condition without charge and within a reasonable time, you may wish to write the Administrator, National Highway Traffic Safety Administration, 400 Seventh St., SW, Washington DC 20590, or call the toll-free Vehicle Safety Hotline at 1.888.327.4236 (TTY 1.800.424.9153), or go to <http://www.safercar.gov>.

Federal regulation requires that any vehicle lessor receiving this recall notice must forward a copy of this notice to the lessee within ten days.

Scott Lawson
General Director,
Customer and Relationship Services

Enclosure
06041