

**GM SERVICE AND PARTS OPERATIONS
DCS1566
URGENT - DISTRIBUTE IMMEDIATELY**

Date: March 28, 2006

Subject: 06026 - Product Safety Recall
Power Steering Hose Separation

Models: 2006 Buick Lucerne with a V8 Engine (RPO LD8)
2006 Cadillac DTS

To: All Buick and Cadillac Dealers

Attention: Service Manager, Parts Manager and Warranty Administrator

IMMEDIATE ACTION REQUIRED

General Motors is announcing Product Safety Recall 06026 today. The total number of vehicles involved is 13,734. Please see the attached bulletin for details.

In order to expedite their repair, a list containing involved VINS currently in dealer inventory is also attached. The list is sorted by dealer Business Associate Code for easy reference. If your code is not listed then none of the involved vehicles have been identified as being in your new vehicle inventory.

Mailing Information

Customer notification mailing will begin March 28, 2006.

GM Vehicle Inquiry System (GMVIS)

GMVIS information will be available March 29, 2006.

Service Information System (SI)

Bulletin 06026 will be available in SI on March 31, 2006.

Campaign Initiation Detail Report (CIDR)

The CIDR will be available in GM DealerWorld the week of April 3rd.

DOUBLE CLICK ON THE ICONS BELOW
THEN SINGLE CLICK ON THE LAUNCH BUTTONS
TO VIEW OR PRINT THE DOCUMENTS

(See attached file: 06026 bulletin.pdf)
(See attached file: US Stock VINS 06026.xls)

END OF MESSAGE
GM SERVICE AND PARTS OPERATIONS



Recall Bulletin



PRODUCT SAFETY RECALL

SUBJECT: Power Steering Hose Separation

MODELS: 2006 Buick Lucerne with a V8 Engine (RPO LD8)
 2006 Cadillac DTS

CONDITION

General Motors has decided that a defect, which relates to motor vehicle safety, exists in **certain** 2006 Buick Lucerne vehicles equipped with a V8 engine (RPO LD8), and Cadillac DTS vehicles. Some of these vehicles may have been built with a power steering hose that is not to specification and may leak fluid. If this were to occur, power steering assist may be lost and increased steering effort would be required at low speeds. If the power steering fluid were to contact hot engine parts, an engine compartment fire could occur.

CORRECTION

Dealers are to replace the power steering hose.

VEHICLES INVOLVED

Involved are **certain** 2006 Buick Lucerne vehicles equipped with a V8 engine (RPO LD8), and Cadillac DTS vehicles built within these VIN breakpoints:

YEAR	DIVISION	MODEL	FROM	THROUGH
2006	Buick	Lucerne	6U146673	6U176682
2006	Cadillac	DTS	6U146663	6U550288

Important: Dealers are to confirm vehicle eligibility prior to beginning repairs by using GMVIS. Not all vehicles within the above breakpoints may be involved.

For dealers with involved vehicles, a listing with involved vehicles containing the complete vehicle identification number, customer name, and address information has been prepared and will be provided through the applicable system listed below. Dealers will not have a report available if they have no involved vehicles currently assigned.

- US GM dealers - GM DealerWorld Recall Information
- Canadian GM dealers - GMinfoNet Recall Reports
- Export dealers - sent directly to dealers

The listing may contain customer names and addresses obtained from Motor Vehicle Registration Records. The use of such motor vehicle registration data for any purpose other than recall is prohibited. Copyright 2006 General Motors Corporation. All Rights Reserved.

than follow-up necessary to complete this recall is a violation of law in several states/provinces/countries. Accordingly, you are urged to limit the use of this report to the follow-up necessary to complete this recall.

PARTS INFORMATION

Parts required to complete this recall are to be obtained from General Motors Service Parts Operations (GMSPO). Please refer to your "involved vehicles listing" before ordering parts. Normal orders should be placed on a DRO = Daily Replenishment Order. In an emergency situation, parts should be ordered on a CSO = Customer Special Order.

Part Number	Description	Quantity/Vehicle
15786639	Hose, P/S Gr Inl	1
89021184 (US) 89021186 (CN)	Fluid, P/S (will service 2 vehicles)	½ bottle

SERVICE PROCEDURE

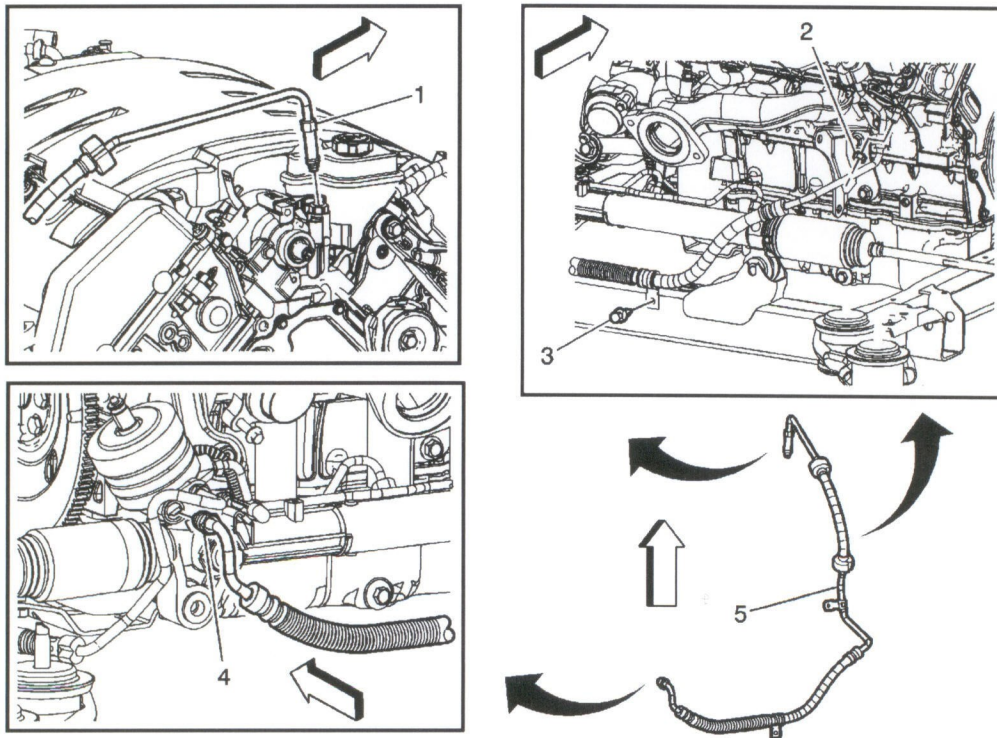

1683880

1. Install fender covers.
2. Install a drain pan under the vehicle.
3. Disconnect the power steering pressure hose (1) from the power steering pump.
4. Raise the vehicle as necessary to access the power steering hose fitting at the rack and pinion.
5. Remove the nut (2) retaining the power steering hose bracket at the cylinder head.
6. Disconnect the push pin (3) connecting the power steering bracket to the frame.
7. Remove 2 bolts from the steering gear heat shield and push the heat shield toward the engine, out of the way.
8. Disconnect the power steering hose (4) from the steering gear.
9. Drain and remove the power steering pressure hose from the vehicle.

10. Install the new power steering pressure hose to the vehicle.
11. Connect the power steering hose (4) to the steering gear.

Tighten

Tighten the power steering pressure hose to the power steering gear to 27 N·m (20 lb ft).

12. Connect the power steering hose bracket to the frame with the push pin (3).
13. Install the power steering hose bracket nut at the cylinder head.

Tighten

Tighten the power steering pressure hose bracket retaining nut to 9 N·m (80 lb in).

14. Position the steering gear heat shield and install the 2 bolts.

Tighten

Tighten the power steering gear heat shield bolts to 9 N·m (80 lb in).

15. Lower the vehicle.
16. Install the power steering pressure hose (1) to the power steering pump.

Tighten

Tighten the power steering pressure hose to the power steering pump to 27 N·m (20 lb ft).

17. Remove the fender covers.
18. Remove the drain pan.
19. Fill and bleed the power steering system. Refer to SI document #1696753.

COURTESY TRANSPORTATION – For US and Canada

The General Motors Courtesy Transportation Program is intended to minimize customer inconvenience when a vehicle requires a repair that is covered by the New Vehicle Limited Warranty. The availability of courtesy transportation to customers whose vehicles are within the warranty coverage period and involved in a product recall is very important in maintaining customer satisfaction. Dealers are to ensure that these customers understand that shuttle service or some other form of courtesy transportation is available and will be provided at no charge. Dealers should refer to the General Motors Service Policies and Procedures Manual for courtesy transportation guidelines.

CLAIM INFORMATION

Submit a Product Recall Claim with the information indicated below:

REPAIR PERFORMED	PART COUNT	PART NO.	PARTS ALLOW	CC-FC	LABOR OP	LABOR HOURS	NET ITEM
Replace Power Steering Hose	1	---	*	MA-96	V1467	0.6	**
Courtesy Transportation for vehicles within the New Vehicle Limited Warranty (US & Canadian GM Dealers)	N/A	N/A	N/A	MA-96	***	N/A	****

- * The "Parts Allowance" should be the sum total of the current GMSP0 Dealer net price plus applicable Mark-Up or Landed Cost Mark-Up (for Export) for the power steering hose needed to complete the repair.
- ** The amount identified in the "Net Item" column should represent the actual sum total of the current GMSP0 Dealer net price plus applicable Mark-Up or Landed Cost Mark-Up (for Export) for the actual amount of power steering fluid needed to perform the required repairs, not to exceed \$1.59 USD, \$1.55 CAD.
- *** Submit courtesy transportation using normal labor operations for courtesy transportation as indicated in the GM Service Policies and Procedures Manual for vehicles within the New Vehicle Limited Warranty.
- **** The amount identified in the "Net Item" column should represent the actual dollar amount for courtesy transportation.

Refer to the General Motors WINS Claims Processing Manual for details on Product Recall Claim Submission.

CUSTOMER NOTIFICATION – For US and Canada

General Motors will notify customers of this recall on their vehicle (see copy of customer letter included with this bulletin).

CUSTOMER NOTIFICATION – For Export

Letters will be sent to known owners of record located within areas covered by the US National Traffic and Motor Vehicle Safety Act. For owners outside these areas, dealers should notify customers using the attached sample letter.

DEALER RECALL RESPONSIBILITY – For US and Export (US States, Territories, and Possessions)

The US National Traffic and Motor Vehicle Safety Act provides that each vehicle that is subject to a recall of this type must be adequately repaired within a reasonable time after the customer has tendered it for repair. A failure to repair within sixty days after tender of a vehicle is prima facie evidence of failure to repair within a reasonable time. If the condition is not adequately repaired within a reasonable time, the customer may be entitled to an identical or reasonably equivalent vehicle at no charge or to a refund of the purchase price less a reasonable allowance for depreciation. To avoid having to provide these burdensome remedies, every effort must be made to promptly schedule an appointment with each customer and to repair their vehicle as soon as possible. In the recall notification letters, customers are told how to

contact the US National Highway Traffic Safety Administration if the recall is not completed within a reasonable time.

DEALER RECALL RESPONSIBILITY – All

All unsold new vehicles in dealers' possession and subject to this recall must be held and inspected/repaired per the service procedure of this recall bulletin before customers take possession of these vehicles.

Dealers are to service all vehicles subject to this recall at no charge to customers, regardless of mileage, age of vehicle, or ownership, from this time forward.

Customers who have recently purchased vehicles sold from your vehicle inventory, and for which there is no customer information indicated on the dealer listing, are to be contacted by the dealer. Arrangements are to be made to make the required correction according to the instructions contained in this bulletin. A copy of the customer letter is provided in this bulletin for your use in contacting customers. Recall follow-up cards should not be used for this purpose, since the customer may not as yet have received the notification letter.

In summary, whenever a vehicle subject to this recall enters your vehicle inventory, or is in your dealership for service in the future, you must take the steps necessary to be sure the recall correction has been made before selling or releasing the vehicle.



April 2006

Dear General Motors Customer:

This notice is sent to you in accordance with the requirements of the National Traffic and Motor Vehicle Safety Act.

General Motors has decided that a defect that relates to motor vehicle safety exists in certain 2006 model year Buick Lucerne vehicles equipped with a V8 engine, and Cadillac DTS vehicles. As a result, GM is conducting a safety recall. We apologize for this inconvenience. However, we have taken this action for your safety and continued satisfaction with our products.

IMPORTANT

- Your vehicle is involved in safety recall 06026.
- Schedule an appointment with your GM dealer.
- This service will be performed for you at **no charge**.

Why is your vehicle being recalled?

Your vehicle may have been built with a power steering hose that is not to specification and may leak fluid. If this were to occur, power steering assist may be lost and increased steering effort would be required at low speeds. If the power steering fluid were to contact hot engine parts, an engine compartment fire could occur.

What will we do?

Your GM dealer will install a new power steering hose. This service will be performed for you at **no charge**. It is likely that your dealer will need your vehicle longer than the actual service correction time of approximately 40 minutes because of service scheduling requirements.

If your vehicle is within the New Vehicle Limited Warranty your dealer may provide you with shuttle service or some other form of courtesy transportation while your vehicle is at the dealership for this repair. Please refer to your Owner's Manual and your dealer for details on courtesy transportation.

What should you do?

You should contact your GM dealer to arrange a service appointment as soon as possible. Bring the enclosed customer reply form with you when you visit your dealer. The form identifies the repairs required. If you no longer own this vehicle, please let us know by completing the form and mailing it back to us.

Do you have questions?

If you have questions or concerns that your dealer is unable to resolve, please contact the appropriate Customer Assistance Center at the number listed below. More information about this recall can be found at the Owner Center at MyGMLink, <http://www.gm.com/recall>

Division	Number	Text Telephones (TTY)
Buick	1-866-608-8080	1-800-832-8425
Cadillac	1-866-982-2339	1-800-833-2622
Guam	1-671-648-8650	
Puerto Rico – English	1-800-496-9992	
Puerto Rico – Español	1-800-496-9993	
Virgin Islands	1-800-496-9994	

If after contacting your dealer and the Customer Assistance Center, you are still not satisfied we have done our best to remedy this condition without charge and within a reasonable time, you may wish to write the Administrator, National Highway Traffic Safety Administration, 400 Seventh St., SW, Washington DC 20590, or call the toll-free Vehicle Safety Hotline at 1.888.327.4236 (TTY 1.800.424.9153), or go to <http://www.safercar.gov>.

Federal regulation requires that any vehicle lessor receiving this recall notice must forward a copy of this notice to the lessee within ten days.

Scott Lawson
General Director,
Customer and Relationship Services

Enclosure
06026