

FILE: SERVICE: GROUP 00 OF SERVICE INFORMATION BINDER
 PARTS: GROUP I OF INFORMATION _ PARTS & ACCESSORIES BINDER

Campaign No. 2006040002, June 2006

Revision History

Revision	Date	Purpose
A	06/09/06	Update of warranty information for repair scenario 3
-	05/09/06	Initial issue

TO: ALL MERCEDES-BENZ CENTERS

SUBJECT: **MODEL 251, MODEL YEAR 2006**
INSPECT STARTER WIRING HARNESS; REPAIR OR REPLACE IF NECESSARY

This Recall Campaign has been initiated because DCAG has determined that on affected vehicles (see VIN range below) the starter wiring harness may be routed incorrectly. This routing could lead to chafing of the protective sleeve covering the starter wiring harness. Over time, such chafing has the potential to wear through the protective sleeve and may expose the underlying starter wiring harness, which could lead to a short in the wiring and the complete loss of function of the electrical system resulting in stalling that could lead to a vehicle crash and in the non operation of the supplemental restraint system.

Please review the Effective Serial Number chart located below.

Prior to performing this Recall Campaign:

- Please check VMI to insure the vehicle is involved and to determine if the vehicle has been previously repaired.
- Please review the entire Recall Campaign bulletin.

Approximately 6,282 vehicles are affected.

Effective Serial Number Range

Models	Chassis End Number	
	From	To
251.165	A000659	A014575

Note:

Every vehicle in the VIN range may not be included in the campaign. VMI must always be checked before performing campaigns to verify that the campaign is required on a specific vehicle. VMI **always** overrides the bulletin in reference to a specific vehicle's inclusion in a particular campaign. Please also note that Recall and Service Campaigns **do not expire** and may also be performed on a vehicle with a vehicle status indicator.

Order No. T-RC-2006040002

This bulletin has been created and maintained in accordance with MBUSA-SLP S423QH001, Document and Data Control, and MBUSA-SLP S424HH001, Control of Quality Records.

Procedure

A. INSPECT STARTER WIRING HARNESS FOR DAMAGE

1. Raise vehicle on lift; refer to WIS document AR00.60-P-1000RT.
2. Inspect starter wiring harness corrugated tube (A, Figure 1) and red insulation (B) for damage in area of engine support shield (C).
 - If the starter wiring harness corrugated tube and insulation are not damaged: perform **SUBJECT B**.
 - If the starter wiring harness corrugated tube is damaged: perform **SUBJECT C**.
 - If the starter wiring harness corrugated tube and red insulation are damaged: perform **SUBJECT D**.

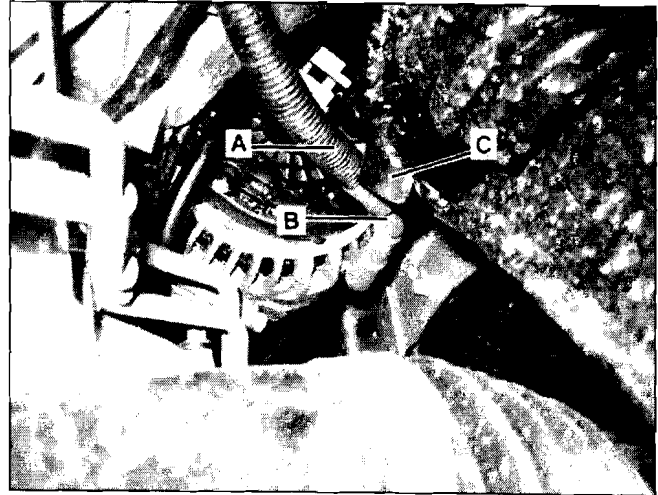

Figure 1

B. FASTEN STARTER WIRING HARNESS TO OIL DIPSTICK GUIDE TUBE

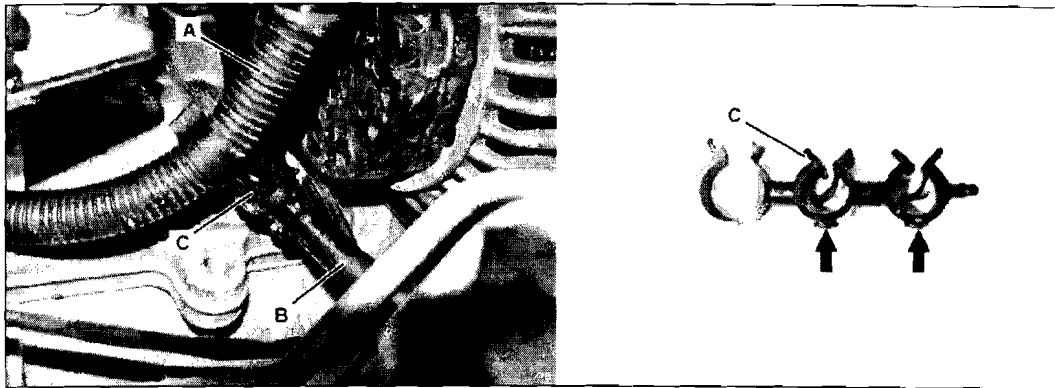

Figure 2

1. Cut off bottom pins (arrows) on the two small clips and assemble clips (C) as shown in Figure 2.
2. Fasten starter wiring harness (A) to oil dipstick guide tube (B) using clips (C).

Note:

The middle clip serves as a spacer; it is not attached to anything.

C. REPAIR STARTER WIRING HARNESS CORRUGATED TUBE

1. Cut open a new 5 cm long corrugated tube (A, Figure 3) lengthwise and install over existing tube (B) in damaged area (circled).
2. Repair paint section on engine support if damaged.
3. Perform **SUBJECT B**: Fasten starter wiring harness to oil dipstick guide tube using clips.

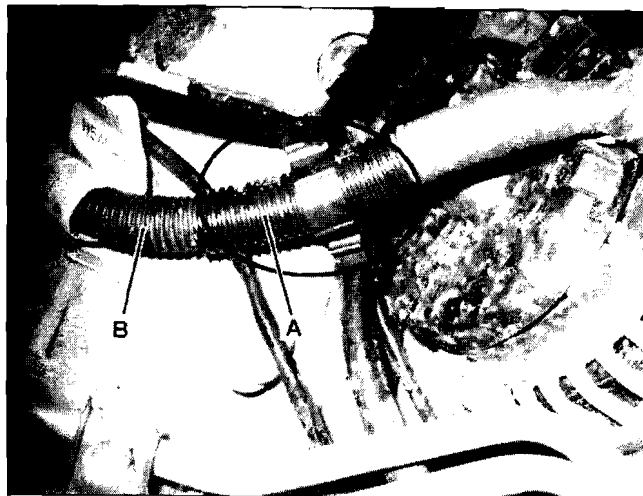

Figure 3

D. REPLACE STARTER WIRING HARNESS

1. Disconnect ground line from battery; refer to WIS document AR54.10-P-0003RT.
2. Remove right catalytic converter; refer to WIS document AR49.10-P-5500RTM.
3. Remove starter (A, Figure 4).
 - Pry cable holder (B) from transmission bracket (C).
 - Remove transmission bracket bolts (D, Figure 4).
 - Remove starter heat shield bolts (E); remove heat shield (F).

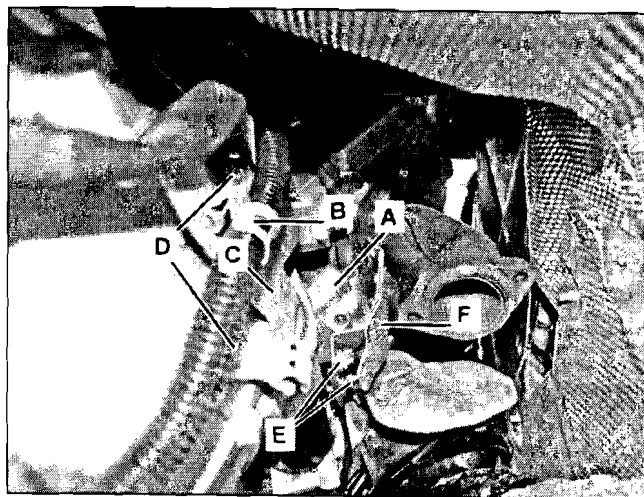

Figure 4

- Remove starter (A, Figure 5) from transmission bellhousing with wires still attached.
- Remove cap from electrical connection C30 bolt (B) and remove bolt; remove electrical connection C50 bolt (C).
- Remove starter from vehicle.

Note:

If additional clearance is required to remove the starter, remove the two motor bolts.

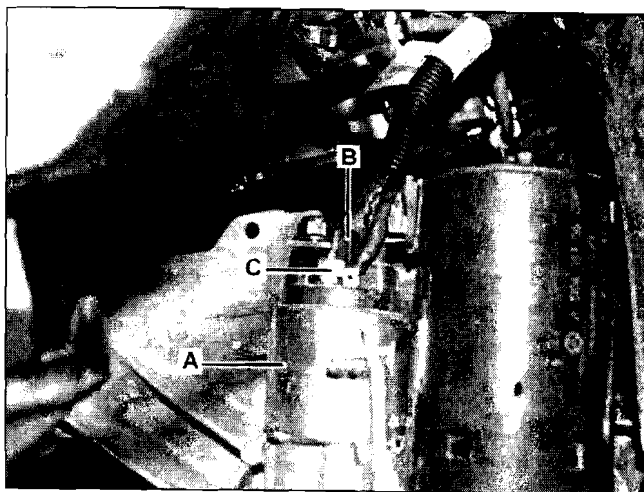

Figure 5

4. Remove cap (A, Figure 6) and disconnect starter wiring harness (B) from alternator (C).
5. Lower vehicle and open hood.

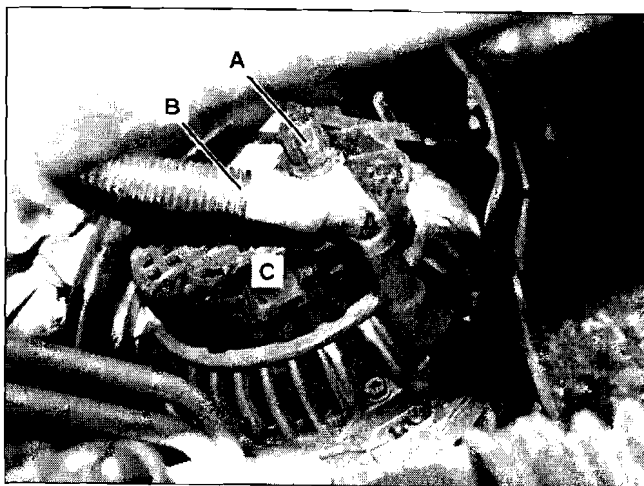

Figure 6

6. Cut wire ties and disconnect starter wiring harness (A, Figure 7) from front prefuse F32 (B).
7. Remove starter wiring harness from vehicle; install new wiring harness in reverse order.
 - Torque bolts on alternator and starter to 15 Nm.
 - Secure new harness with cable ties.
8. Assemble in reverse order.
9. Repair paint section on engine support if damaged.

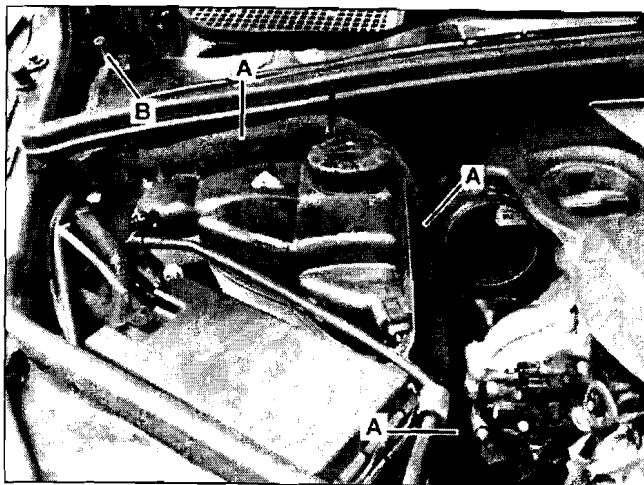
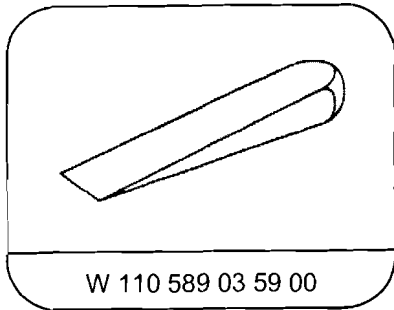

Figure 7

10. Perform **SUBJECT B**: Fasten starter wiring harness to oil dipstick guide tube using clips.
11. Perform basic programming; refer to WIS document AR00.19-P-0200RT.

Special Tools



Mounting Wedge

Note: The noted Special Tool is classified as a “K” tool and can be ordered at the discretion of the dealer.

Primary Parts Information

Qty.	Part Name	Part Number	Estimated Replacement Rate
	Clip	A 000 995 23 65	100%
	Clip	A 000 995 66 65	

THE FOLLOWING SECONDARY PART(S) IS/ARE **NOT** TO BE ORDERED IN EQUAL QUANTITIES AS THE PRIMARY PART(S). THEREFORE DO NOT PACKAGE OR KIT CAMPAIGN PARTS TOGETHER SINCE NOT ALL VEHICLES WILL REQUIRE THESE PARTS

Secondary Parts Information

Qty.	Part Name	Part Number	Estimated Replacement Rate
1	Corrugated Tube (5 cm) ¹⁾	A 000 546 70 30	70%
1	Starter Wiring Harness ²⁾	A 251 540 15 30	5%

Note:

¹⁾ 1 meter of corrugated tube is sufficient for 20 vehicles. Submit as a Sublet, utilizing sublet code of “SUB” for \$0.18 (handling is included).

²⁾ Returned parts will be inspected for damage and dealer will be debited if no evidence of damage is found.

Note:

- Please be aware that only the part number(s) referenced in the Campaign Bulletin is/are approved for use to repair the vehicle. Repairs performed using any other part(s) will not have been performed in accordance with the campaign. Accordingly, warranty claims submitted with reference to an improper part number(s) will be denied.
- The following allowable labor operation should be used when submitting a warranty claim for this repair:

Warranty Information**Repair 1 (Check and Fasten)****Operation:** Starter Wiring Harness Corrugated Tube, Check (02-5331)

Clip for Starter Wiring Harness (After Check), Install (02-5332)

Damage Code	Operation Number	Labor Time (hrs.)	Model Indicator(s)
59 910 35 7	02-5331	0.3	BA
	02-5332	0.1	BA

Repair 2 (Check, Fasten and Repair Harness)**Operation:** Starter Wiring Harness Corrugated Tube, Check (02-5331)

Clip for Starter Wiring Harness (After Check), Install (02-5332)

Corrugated Tube in Damaged Area (After Check), Install (02-5333)

Damage Code	Operation Number	Labor Time (hrs.)	Model Indicator(s)
59 910 35 7	02-5331	0.3	BA
	02-5332	0.1	BA
	02-5333	0.1	BA

Repair 3 (Check, Fasten and Replace Harness)**Operation:** Starter Wiring Harness Corrugated Tube, Check (02-5331)

Clip for Starter Wiring Harness (After Check), Install (02-5332)

Starter Wiring Harness (After Check), Replace (Model 251) (02-5334)

Damage Code	Operation Number	Labor Time (hrs.)	Model Indicator(s)
59 910 35 7	02-5331	0.3	BA
	02-5332	0.1	BA
	02-5334	2.1	BA

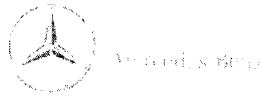

Mercedes-Benz USA, LLC

Mercedes-Benz
2006 R-Class

Safety Recall #2006040002

May, 2006

Dear Mercedes-Benz Owner

This notice is sent to you in accordance with the requirements of the National Traffic and Motor Vehicle Safety Act. WE SENT YOU THIS NOTICE BECAUSE WE ARE CONCERNED ABOUT YOUR SAFETY.

DaimlerChrysler AG (DCAG), the manufacturer of Mercedes-Benz vehicles, has decided that a defect which relates to motor vehicle safety exists in certain Model Year 2006 R-Class vehicles with regard to the starter wiring harness. Mercedes-Benz USA, LLC (MBUSA) therefore has initiated a recall of these vehicles. Our records indicate that your vehicle is included in the affected population of vehicles.

DCAG has determined that the starter wiring harness may be routed incorrectly. This routing could lead to chafing of the protective sleeve covering the starter wiring harness. Over time, such chafing has the potential to wear through the protective sleeve and may expose the underlying starter wiring harness, which could lead to a short in the wiring and the complete loss of function of the electrical system resulting in stalling that could lead to a vehicle crash and in the non operation of the supplemental restraint system.

Your authorized Mercedes-Benz dealer will inspect and where necessary, correct the routing of the wiring harness. In case of wear, the protective sleeve, and if necessary, the starter harness will be replaced. This service will be provided free of charge. The working time required to repair this condition is approximately 1 hour. As a matter of normal service process, your authorized Mercedes-Benz dealer will also check for other repair measures which might be applicable to your vehicle and this may increase the required working time. Please contact your authorized Mercedes-Benz dealer for additional information and to schedule an appointment at your earliest convenience. Please mention Recall Campaign #2006040002.

If you are no longer the vehicle owner, or have a change of address, please complete the reverse side of this letter and return the complete letter in the enclosed envelope. If this is a leased vehicle and the lessor and registered owner receive this notice, please forward this information by first class mail to the lessee.

Please contact your authorized Mercedes-Benz dealer should you have any questions or encounter any difficulty regarding this recall. If your dealer is unable to remedy your situation please contact us at 1-(800) FOR-MERCEdes (1-800-367-6372).

If an authorized Mercedes-Benz dealer or Mercedes-Benz USA, LLC, fails or is unable to perform this service without charge within 60 days, pursuant to law 49 U.S.C. Chapter 301, you may submit a complaint to the Administrator, National Highway Traffic Safety Administration, 400 Seventh Street, S.W., Washington, D.C. 20590 or call the toll-free Auto Safety Hotline at 1-888-327-4236 (TTY 1-800-424-9153); or go to <http://www.safercar.gov>.

We apologize for any inconvenience this situation may cause you.

Sincerely,

One Mercedes Drive, P.O. Box 990, Montvale, NJ 07645-0350, Phone 1-800-FOR-MERCEdes (1-800-367-6372), Fax (201) 476-6911
www.MBUSA.com

Mercedes-Benz registered trademarks of DaimlerChrysler AG, Stuttgart, Federal Republic of Germany

