

TOYOTA CUSTOMER SERVICES

Volume: XIII
Number: TC06-003
Date: 03/28/2006
 Action
 Retain
 Information

RECEIVED

2006 APR 12 A 9:58

INTEROFFICE MEMORANDUM

TO: ALL REGION/PRIVATE DISTRIBUTOR GENERAL MANAGERS/
VICE PRESIDENTS

FROM: DAVE ZELLERS, *Dave*
VICE PRESIDENT, PRODUCT QUALITY & SERVICE SUPPORT

SUBJECT: SPECIAL SERVICE CAMPAIGN (SSC) – 60B (SAFETY RECALL)
(SUPPLEMENTAL RESTRAINT SYSTEM (SRS) AIRBAG REPLACEMENT)

Toyota will initiate a Special Service Campaign to replace specific SRS airbag assemblies (Side Airbag, Curtain Side Airbag or Driver Knee Airbag dependent upon the exact VIN) on 73 Toyota vehicles. The 73 vehicles consist of certain 2005 – 2006 Model Year Avalon, 2007 Model Year Camry, 2004 – 2006 Model Year Prius, 2005 Model Year RAV4, 2005 – 2006 Model Year Scion tC, and 2005 – 2006 Model Year Tacoma vehicles. Please refer to the technical instructions to determine the exact VIN and specific airbag assembly which requires replacement.

Due to improper assembly of the airbag inflator, which is incorporated into the SRS airbag assembly (Side Airbag, Curtain Side Airbag or Driver Knee Airbag), some inflators were produced with an insufficient amount of the heating agents necessary for proper airbag deployment. In this condition, the expansion force of the gas may be insufficient to properly inflate the airbag when the SRS system is activated during a collision.

The following vital information is provided to inform you and your staff of the owner notification phase of the campaign and your degree of involvement.

1. **Dealer Letter Mailing Date**

The attached Dealer Letter will be sent to all Toyota dealers in early April, 2006.

2. **Owner Notification Mailing Date**

The owner notification will commence in early April, 2006.

Please note that only owners of the affected vehicles will be notified. If a dealer is contacted by an owner of an involved vehicle, who has not yet received a notification, please instruct them to **verify eligibility by confirming through Dealer Daily/TIS prior to performing repairs**. Dealers should perform the inspection as outlined in the attached Technical Instructions.

3. **Number of Vehicles Involved**

The approximate numbers of vehicles involved in the U.S. are:

Model Year	Model	Number of Vehicles Involved
2005 – 2006	Avalon	6
2007	Camry	1
2004 – 2006	Prius	46
2005	RAV4	1
2005 – 2006	Scion tC	17
2005 – 2006	Tacoma	2
Total		73

4. **Region/District Summary Reports**

Due to the limited number of vehicles involved in this campaign no Region/District reports will be provided for this issue. However, please refer to the attached VIN list of affected vehicles.

5. **Vehicles in Dealer Stock**

As required by Federal Regulation, dealers are not to deliver any vehicle acquired in their inventory, which is involved in a safety recall, until the necessary inspections/replacements have been performed.

6. **Parts Ordering**

Since only 73 specific vehicles are affected, dealers will not be allowed to stock the airbag assemblies. They will be placed on Manual Allocation Control. The Owner Letter requests the customers of the affected vehicles to contact their dealer, providing them with their VIN so that the correct parts can be ordered. To assist dealers in determining the correct part number to order, a website has been set up to look up part numbers by VIN. Please go to http://60b-lookup.imagespm.info/fra_home.cfm (also linked through TIS), enter the VIN, and the correct part number to order will be displayed. ***The website is for part application reference only and will not order the part nor will it confirm campaign completion status.***

If there are ***special*** circumstances where a dealer is having difficulty receiving parts, dealer associates may contact 310-468-5516 to research the airbag assembly order. The associate should have the following information ready to expedite research of the order status:

- Dealer Information (Dealer Code, Contact Name, Telephone Number)
- Order Reference Number
- Customer Name and Vehicle 17-digit VIN

Due to the small number of vehicles involved, if dealerships experience slight delays in receiving parts, a customer rental car through the Toyota Rent-A-Car (TRAC) Program is available. Follow the Toyota Transportation Assistance Program (TTAP) guidelines. DSPM authorization will be required for vehicle rentals exceeding 3 days.

7. **Repair Procedures**

Refer to the attached Technical Instructions and appropriate Repair Manual as indicated.

Please review this entire Special Service Campaign package with the appropriate associates so that they may provide the necessary support to your dealers and maximize our combined customer satisfaction efforts.

Thank you for your cooperation.

TOYOTA MOTOR SALES, U.S.A, INC.

Enclosures

cc: Region/Private Distributor Assistant General Managers
Region/Private Distributor Customer Service Operations Managers
Region/Private Distributor Service Managers/Directors/VPs
Region/Private Distributor Parts Managers/Directors/VPs
Region/Private Distributor Customer Services Field Managers
Region/Private Distributor Technical Services and Training Managers
Region/Private Distributor District Service and/or Parts Managers
Region/Private Distributor Customer Relations Managers
Region/Private Distributor PDC Managers
Region/Private Distributor Field Technical Specialists
Region/Private Distributor Service Training Specialists
Region/Private Distributor Vehicle Operations Managers
All NAPC General Managers
All TMS Sales Administration Managers
All TMS Product Quality & Service Support Managers
All Field Product Engineers

E. Bastien	D. Fleming	T. Nagashino
J. Beseda	Y. Funo	D. Ogilvie
G. Borst	J. Hanson	K. Ohara
R. Broughman	J. Hollis	D. Pettitt
G. Bryan	D. Illingworth	J. Press
A. Cabito	J. Kerr	M. Reding
D. Camden	M. King	R. Specht
B. Carter	J. Kobayashi	J. Stempkowski
J. Chernus	J. Lang	F. Stolle
B. Cooper	J. Lentz	H. Sunakawa
R. Daly	E. Matsuda	E. Taira
D. Danzer	T. Matsuno	T. Takada
A. DeCarr	D. Mercer	J. Tetherow
T. Devany	M. Michels	A. Vaish
T. Doi	I. Miller	R. Waltz
B. Ertmann	M. Mori	M. Yamaguchi
D. Esmond	M. Morrison	
G. Fogg	E. Nagano	



Toyota Motor Sales, U.S.A., Inc.
19001 South Western Avenue
P.O. Box 2991
Torrance, CA 90509-2991

TO: ALL TOYOTA DEALER PRINCIPALS,
SERVICE MANAGERS, PARTS MANAGERS

SUBJECT: SPECIAL SERVICE CAMPAIGN (SSC) – 60B (SAFETY RECALL)
(SUPPLEMENTAL RESTRAINT SYSTEM (SRS) AIRBAG REPLACEMENT))

Toyota will initiate a Special Service Campaign to replace specific SRS airbag assemblies (Side Airbag, Curtain Side Airbag or Driver Knee Airbag dependent upon the exact VIN) on 73 Toyota vehicles. The 73 vehicles consist of certain 2005 – 2006 Model Year Avalon, 2007 Model Year Camry, 2004 – 2006 Model Year Prius, 2005 Model Year RAV4, 2005 – 2006 Model Year Scion tC, and 2005 – 2006 Model Year Tacoma vehicles. Please refer to the technical instructions to determine the exact VIN and specific airbag assembly which requires replacement.

Due to improper assembly of the airbag inflator, which is incorporated into the SRS airbag assembly (Side Airbag, Curtain Side Airbag or Driver Knee Airbag), some inflators were produced with an insufficient amount of the heating agents necessary for proper airbag deployment. In this condition, the expansion force of the gas may be insufficient to properly inflate the airbag when the SRS system is activated during a collision.

The following vital information is provided to inform you and your staff of the owner notification phase of the campaign and your degree of involvement.

1. **Owner Notification Letter Mailing Date**

The owner notification will commence in early April, 2006.

Please note that only owners of the affected vehicles will be notified. If a dealer is contacted by an owner of an involved vehicle, who has not yet received a notification, please instruct them to **verify eligibility by confirming through Dealer Daily/TIS prior to performing repairs**. Dealers should perform the inspection as outlined in the attached Technical Instructions.

2. **Vehicles in Dealer Stock**

As required by Federal Regulation, dealers are not to deliver any vehicle acquired in their inventory, which is involved in a safety recall, until the necessary inspections/replacements have been performed.

3. **Dealer/Owner Lists**

Due to the limited number of vehicles involved in this campaign no Dealer/Owner list will be provided for this issue. However, please refer to the attached VIN list of affected vehicles.

4. Number and Identification of Involved Vehicles

The approximate numbers of vehicles involved in the U.S. are:

Model Year	Model	Vehicle's Involved
2005 – 2006	Avalon	6
2007	Camry	1
2004 – 2006	Prius	46
2005	RAV4	1
2005 – 2006	Scion tC	17
2005 – 2006	Tacoma	2
Total		73

Please note that only owners of the affected vehicles will be notified. If a dealer is contacted by an owner of an involved vehicle, who has not yet received a notification, please instruct them to **verify eligibility by confirming through Dealer Daily/TIS prior to performing repairs**. Dealers should perform the inspection as outlined in the attached Technical Instructions.

5. Parts Ordering

Since only 73 specific vehicles are affected, dealers will not be allowed to stock the airbag assemblies. They will be placed on Manual Allocation Control. The Owner Letter requests the customers of the affected vehicles to contact their dealer, providing them with their VIN so that the correct parts can be ordered. To assist dealers in determining the correct part number to order, a website has been set up to look up part numbers by VIN. Please go to http://60b-lookup.imagespm.info/fra_home.cfm (also linked through TIS), enter the VIN, and the correct part number to order will be displayed. **The website is for part application reference only and will not order the part nor will it confirm campaign completion status.**

If there are **special** circumstances where a dealer is having difficulty receiving parts, dealer associates may contact 310-468-5516 to research the airbag assembly order. The associate should have the following information ready to expedite research of the order status:

- Dealer Information (Dealer Code, Contact Name, Telephone Number)
- Order Reference Number
- Customer Name and Vehicle 17-digit VIN

Due to the small number of vehicles involved, if dealerships experience slight delays in receiving parts, a customer rental car through the Toyota Rent-A-Car (TRAC) Program is available. Follow the Toyota Transportation Assistance Program (TTAP) guidelines. DSPM authorization will be required for vehicle rentals exceeding 3 days.

A UIO by state matrix for **all models** is listed below to inform dealers of the number of vehicles in their area.

STATE	UIO	STATE	UIO	STATE	UIO	STATE	UIO	STATE	UIO
AK	0	GA	0	ME	1	NJ	2	SD	1
AL	1	IA	0	MI	3	NM	0	TN	0
AR	0	ID	0	MN	2	NV	0	TX	5
AZ	0	IL	3	MO	3	NY	8	UT	0
CA	17	IN	1	MS	0	OH	2	VA	3
CO	2	KS	0	MT	0	OK	0	VT	0
CT	3	KY	0	NC	1	OR	0	WA	3
DC	0	LA	0	ND	0	PA	4	WI	3
DE	0	MA	3	NE	0	RI	0	WV	0
FL	1	MD	1	NH	0	SC	0	WY	0

6. Repair Procedures

Refer to the attached Technical Instructions and appropriate Repair Manual as indicated.

7. Disposal of Undeployed Airbags

Undeployed airbags may be considered hazardous waste in certain states. In those states, they must be disposed of in the proper manner according to local, state, and federal regulations for hazmat waste. In most states the undeployed airbag will need to be picked up for disposal by a Hazmat disposal company.

8. Reimbursement Procedures

Submit Special Service Campaign claims following the procedures described in the Toyota Warranty Policy and Procedures Manual.

The operation codes to be used for this campaign are:

SSC #	Op. Code	Description	Vehicle Application	Flat Rate Hour
60B	6508CA	Replace left or right curtain side airbag	Camry	3.4 hr/vehicle
	6508CB	Replace left or right curtain side airbag	Prius	3.6 hr/vehicle
	6508CD	Replace driver or passenger side airbag (seat assembly replacement)	Tacoma	0.5 hr/vehicle
	6508CF	Replace driver or passenger side airbag (seat assembly replacement)	RAV4	0.4 hr/vehicle
	6508CG	Replace driver or passenger side airbag (seat assembly replacement)	Prius Scion tC	0.4 hr/vehicle
	6508CH	Replace the driver side knee airbag	Avalon	0.6 hr/vehicle
	6508CQ	Replace the driver side knee airbag	Scion tC	0.5 hr/vehicle

NOTE: The above flat rate time(s) include 0.1 hour in each campaign for administrative cost per unit for the dealership.

The undeployed airbag may require Hazmat disposal in some states. Hazmat disposal costs for each airbag may be claimed as a sublet type "ZZ". Hazmat disposal reimbursement is normally excluded under Policy and is specific to this SSC only as a one-time exception.

Due to the small number of vehicles involved, if dealerships experience slight delays in receiving parts, a customer rental car through the Toyota Rent-A-Car (TRAC) Program is available. Follow the Toyota Transportation Assistance Program (TTAP) guidelines. DSPM authorization will be required for vehicle rentals exceeding 3 days.

Please review this entire package with your Service and Parts staff to familiarize them with the proper step-by-step procedures required to implement this Special Service Campaign.

Thank you for your cooperation.
TOYOTA MOTOR SALES, U.S.A., INC.

60B VIN Dealer List
73 VINs Total

MODEL	VIN	REGION	SVC DLR	DEALER NAME
PRIUS	JTDKB20U757043153	11	04034	QUALITY TOYOTA
tC	JTKDE177960098197	11	04080	PENSKE TOYOTA
PRIUS	JTDKB20U853119938	11	04308	WONDRIES TOYOTA
PRIUS	JTDKB20UX63133342	11	04347	FRONTIER TOYOTA
tC	JTKDE167960086083	11	04347	FRONTIER TOYOTA
PRIUS	JTDKB20U053057239	12	04001	RON GOODE TOYOTA
PRIUS	JTDKB20U557025184	12	04072	HANSEL TOYOTA
PRIUS	JTDKB20U453032912	12	04088	SAN FRANCISCO TOYOTA
tC	JTKDE177660086007	12	04098	MICHAEL TOYOTA
PRIUS	JTDKB20U457046916	12	04313	HOBBIE AUTO CENTER
PRIUS	JTDKB20U253107221	12	04338	FREMONT TOYOTA
PRIUS	JTDKB20U557047136	12	04338	FREMONT TOYOTA
PRIUS	JTDKB20U453098876	12	04346	PIERCEY TOYOTA
AVALON	4T1BK36B15U006835	12	04426	CAPITOL TOYOTA
PRIUS	JTDKB20U753107358	12	04426	CAPITOL TOYOTA
PRIUS	JTDKB20U953107684	12	04426	CAPITOL TOYOTA
tC	JTKDE177350020190	12	04426	CAPITOL TOYOTA
PRIUS	JTDKB20U553106533	13	46073	I-5 TOYOTA
PRIUS	JTDKB20U353038281	13	46076	BURIEN TOYOTA
TACOMA	5TELU42N96Z190357	13	46090	MAGIC TOYOTA
PRIUS	JTDKB20U253119563	15	05043	LONGMONT TOYOTA, INC
CAMRY	JTNBK46K873000030	15	05999	DENVER REGION
AVALON	4T1BK36B36U088598	16	06026	GALE TOYOTA, INC.
tC	JTKDE177160089347	16	06039	TOYOTA OF WESTPORT
PRIUS	JTDKB20U440024826	16	06042	HOFFMAN TOYOTA
PRIUS	JTDKB20U553036838	16	06047	TOYOTA OF WALLINGFOR
PRIUS	JTDKB20U967062840	16	29008	PARKWAY TOYOTA
PRIUS	JTDKB20UX57010518	16	29081	CRESTMONT TOYOTA
PRIUS	JTDKB20U763134951	16	29098	MULLER TOYOTA
tC	JTKDE177960098054	16	29099	TOYOTA OF TURNERSVIL
PRIUS	JTDKB20U867061372	16	31062	TOYOTA NORTH
PRIUS	JTDKB20U453107673	16	31098	KENT BROWN TOYOTA
PRIUS	JTDKB20U453021425	16	31116	NEW COUNTRY TOYOTA
AVALON	4T1BK36BX5U044323	16	31119	LIA TOYOTA OF COLONI
PRIUS	JTDKB20U040009577	16	31119	LIA TOYOTA OF COLONI
tC	JTKDE177450057216	16	31136	VANDERSTYNE TOYOTA
PRIUS	JTDKB20U363135028	17	18023	SHEPARD TOYOTA
PRIUS	JTDKB20U753119574	17	20051	COPELAND TOYOTA
PRIUS	JTDKB20U553120318	17	20113	TOYOTA OF WELLESLEY
PRIUS	JTDKB20U253117005	17	20119	HYANNIS TOYOTA
tC	JTKDE167960086987	21	12103	GREEN TOYOTA
PRIUS	JTDKB20U740032113	21	12144	LIBERTYVILLE TOYOTA
AVALON	4T1BK36B65U002814	21	13049	BECK TOYOTA
PRIUS	JTDKB20U340032190	21	22017	CHESTER BERG TOYOTA
tC	JTKDE177450043655	21	22041	BURNSVILLE TOYOTA
RAV4	JTEHD20V556044476	21	48027	MARKQUART TOYOTA
PRIUS	JTDKB20U753099407	21	48030	WILDE TOYOTA, INC.
tC	JTKDE167960087296	21	48045	HESSER TOYOTA
PRIUS	JTDKB20U140028512	21	48053	RUDA CHEVROLET/TOYOT
tC	JTKDE177060083247	22	21065	TOYOTA OF GRAND RAPI

MODEL	VIN	REGION	SVC DLR	DEALER NAME
PRIUS	JTDKB20U553003208	22	21093	FOX TOYOTA
tC	JTKDE177060107644	22	21110	VICTORY TOYOTA
PRIUS	JTDKB20U657047114	22	34070	TOYOTA DIRECT
AVALON	4T1BK36B05U014165	22	34089	TOYOTA OF CINCINNATI
PRIUS	JTDKB20U540025760	23	24022	SEEGER TOYOTA
PRIUS	JTDKB20U163137165	23	24045	LOU FUSZ TOYOTA
PRIUS	JTDKB20U753122930	23	24077	JAY WOLFE TOYOTA OF
PRIUS	JTDKB20U057047416	23	40011	BILLION TOYOTA
PRIUS	JTDKB20U153099693	50	01059	SERRA TOYOTA, INC.
PRIUS	JTDKB20UX53005973	50	09205	KEITH PIERSON TOYOTA
tC	JTKDE167060089521	50	32001	RICE TOYOTA
PRIUS	JTDKB20U063134676	60	42208	METROPLEX TOYOTA
tC	JTKDE177150005378	60	42215	STEWART TOYOTA
tC	JTKDE167X60102632	60	42263	ATKINSON TOYOTA
AVALON	4T1BK36B96U086659	60	42268	TEXAS TOYOTA OF GRAP
tC	JTKDE177060086763	60	42282	FRED HAAS TOYOTA COU
tC	JTKDE177560086256	80	19026	KOONS TOYOTA
PRIUS	JTDKB20U163132824	80	37134	WILLIAMS TOYOTA
PRIUS	JTDKB20U353056361	80	37167	SAVAGE TOYOTA
PRIUS	JTDKB20U453107527	80	37172	CONICELLI TOY/SPRING
PRIUS	JTDKB20U953094452	80	45035	LUSTINE TOYOTA/DODGE
TACOMA	5TELU42N75Z081376	80	45038	OAK RIDGE TOYOTA
PRIUS	JTDKB20U763135307	80	45062	PRIORITY TOYOTA

**SSC 60B – Supplemental Restraint System (SRS) Airbag Replacement
SAFETY RECALL NOTICE**

DRAFT

Dear Toyota Customer:

Re: Your Vehicle, [VIN]

This notice is being sent to you in accordance with the requirements of the National Traffic and Motor Vehicle Safety Act. Toyota has decided that a defect, which relates to motor vehicle safety, exists in certain SRS airbag assemblies equipped in specific Toyota vehicles.

What is the problem?

Due to improper assembly of the airbag inflator, which is incorporated into the SRS airbag assembly (Side Airbag, Curtain Side Airbag or Driver Knee Airbag), some inflators were produced with an insufficient amount of the heating agents necessary for proper airbag deployment. In this condition, the expansion force of the gas may be insufficient to properly inflate the airbag when the SRS system is activated during a collision. In the worst case, this may increase the risk of injury to the occupant in the involved seating position in the event of a crash. Your vehicle has been identified by the airbag serial number and the Vehicle Identification Number as requiring an airbag replacement.

What will Toyota do?

Based upon your Vehicle Identification Number (VIN), any Toyota dealer will replace the specific SRS airbag requiring replacement. This repair will be conducted at **NO CHARGE** to you.

What should you do?

Please contact your authorized Toyota dealer to make an appointment so your dealer can order the airbag specific to your vehicle. You will need your Vehicle Identification Number (provided at the top of this letter) when making the appointment. We request that you replace the airbag as soon as possible.

The replacement will take approximately three hours. However, depending upon the dealer's work schedule, it may be necessary to make your vehicle available for a longer period of time.

We request that you present this notice to the dealer at the time of your service appointment.

If you no longer own the vehicle, please indicate so on the enclosed postage-paid form, providing us with the name and address of the new owner.

What if you have other questions?

Your local Toyota dealer will be more than happy to answer any of your questions and set up an appointment to perform the inspection. If you require further assistance, you may contact the Toyota Customer Experience Center at 1-888-270-9371 Monday through Friday, 5:00 am to 9:30 pm, Saturday and Sunday 7:00 am through 3:00 pm Pacific Standard Time.

If you believe that the dealer or Toyota has failed or is unable to remedy the defect within a reasonable time, you may submit a complaint to the Administrator, National Highway Traffic Safety Administration, 400 Seventh Street S.W., Washington, D.C. 20590, or call the toll free Auto Safety Hot Line at 1-888-327-4236 (TTY: 1-800-424-9153), or go to <http://www.safercar.gov>.

If you are a vehicle lessor, Federal law requires that any vehicle lessor receiving this recall notice must forward a copy of this notice to the lessee within ten days.

We have sent this notice in the interest of your continued satisfaction with our products, and we sincerely regret any inconvenience this condition may have caused you.

Thank you for driving a Toyota.

Sincerely,

TOYOTA MOTOR SALES, U.S.A., INC.

**SSC 60B – Supplemental Restraint System (SRS) Airbag Replacement
SAFETY RECALL NOTICE**

DRAFT

Dear Scion Customer:

Re: Your Vehicle, [VIN]

This notice is being sent to you in accordance with the requirements of the National Traffic and Motor Vehicle Safety Act. Toyota has decided that a defect, which relates to motor vehicle safety, exists in certain SRS airbag assemblies equipped in specific Scion vehicles.

What is the problem?

Due to improper assembly of the airbag inflator, which is incorporated into the SRS airbag assembly (Side Airbag or Driver Knee Airbag), some inflators were produced with an insufficient amount of the heating agents necessary for proper airbag deployment. In this condition, the expansion force of the gas may be insufficient to properly inflate the airbag when the SRS system is activated during a collision. In the worst case, this may increase the risk of injury to the occupant in the involved seating position in the event of a crash. Your vehicle has been identified by the airbag serial number and the Vehicle Identification Number as requiring an airbag replacement.

What will Scion/Toyota do?

Based upon your Vehicle Identification Number (VIN), any Scion or Toyota dealer will replace the specific SRS airbag requiring replacement. This repair will be conducted at **NO CHARGE** to you.

What should you do?

Please contact your authorized Scion or Toyota dealer to make an appointment so your dealer can order the airbag specific to your vehicle. You will need your Vehicle Identification Number (provided at the top of this letter) when making the appointment. We request that you replace the airbag as soon as possible.

The replacement will take approximately one hour. However, depending upon the dealer's work schedule, it may be necessary to make your vehicle available for a longer period of time.

We request that you present this notice to the dealer at the time of your service appointment.

If you no longer own the vehicle, please indicate so on the enclosed postage-paid form, providing us with the name and address of the new owner.

What if you have other questions?

Your local Scion or Toyota dealer will be more than happy to answer any of your questions and set up an appointment to perform the installation. If you require further assistance, you may contact the Scion Customer Experience Center at 1-866-548-1851 Monday through Friday, 5:00 am to 9:30 pm, Saturday and Sunday 7:00 am through 3:00 pm Pacific Standard Time.

If you believe that the dealer or Scion has failed or is unable to remedy the defect within a reasonable time, you may submit a complaint to the Administrator, National Highway Traffic Safety Administration, 400 Seventh Street S.W., Washington, D.C. 20590, or call the toll free Auto Safety Hot Line at 1-888-327-4236 (TTY: 1-800-424-9153), or go to <http://www.safercar.gov>.

If you are a vehicle lessor, Federal law requires that any vehicle lessor receiving this recall notice must forward a copy of this notice to the lessee within ten days.

We have sent this notice in the interest of your continued satisfaction with our products, and we

sincerely regret any inconvenience this condition may have caused you.

Thank you for driving a Scion.

Sincerely,

Scion,
A Marque of Toyota Motor Sales, U.S.A., Inc.



**Special Service Campaign (SSC) 60B Q&A
Supplemental Restraint System (SRS) Airbag Replacement**

Q1: What is the condition?

A1: Due to improper assembly of the airbag inflator, which is incorporated into the SRS airbag assembly (Side Airbag, Curtain Side Airbag or Driver Knee Airbag), some inflators were produced with an insufficient amount of the heating agents necessary for proper airbag deployment. In this condition, the expansion force of the gas may be insufficient to properly inflate the airbag when the SRS system is activated during a collision.

Q2: What is the cause of this condition?

A2: This condition is caused by the improper assembly of the airbag inflator.

Q3: Are there any warnings that this condition exists?

A3: No, there are no warnings that this condition will occur.

Q4: Which and how many vehicles are involved?

A4: There are 6 Avalon (2005 and 2006 MY), 2 Tacoma (2005 and 2006 MY), 46 Prius (2004, 2005 and 2006 MY), 1 RAV4 (2005 MY), 1 Camry (2007 MY) and 17 Scion tC (2005 and 2006 MY)

Q5: Are there any other Toyota, Scion or Lexus vehicles involved?

A5: Yes, there are some Lexus vehicles which are involved. They are 13 GS 300 (2006 MY), 4 GS 430 (2006 MY), 11 IS 250 (2006 MY), 9 IS 350 (2006 MY) and 23 LS 430 (2004, 2005 and 2006 MY) vehicles.

Q6: What is the production period of the affected vehicles?

A6: The affected Toyota, Scion and Lexus vehicles were produced between September 29, 2003 and January 10, 2006.

Q7: How many incidents of this condition have been reported?

A7: There have been no cases reported for this condition in the affected vehicles.

Q8: Have there been any accidents reported?

A8: There have been no reported cases of accidents related to this condition.

Q9: What is Toyota/Scion going to do?

A9: Owners of the involved vehicles will receive a Special Service Campaign notification by first class mail beginning in mid-April, 2006. Toyota/Scion dealers will replace the specific SRS Airbag at **NO CHARGE** to the vehicle owners.

Q10: How long will the repair take?

A10: The repair will take approximately three hours. However, depending upon the dealer's work schedule, it may be necessary to make the vehicle available for a longer period of time.

Q11: What should an owner do if they have a problem with their SRS Airbag?

A11: Owners are requested to contact their local Toyota/Scion dealer for diagnosis and repair.

TECHNICAL INSTRUCTIONS
FOR
SPECIAL SERVICE CAMPAIGN 60B

AIRBAG REPLACEMENT
FOR THE FOLLOWING VEHICLES

2005 THROUGH 2006 AVALON
2007 CAMRY
2004 THROUGH 2006 PRIUS
2005 RAV4
2005 THROUGH 2006 SCION tC
2005 THROUGH 2006 TACOMA

(73 Specific VINs Only!)

TABLE OF CONTENTS

Avalon Airbag Replacement.....	Page 03
Camry Airbag Replacement.....	Page 06
Prius Airbag Replacement.....	Page 09
RAV4 Airbag Replacement.....	Page 15
Scion tC Airbag Replacement.....	Page 18
Tacoma Airbag Replacement.....	Page 22
Undeployed Airbag Disposal.....	Page 25

AVALON AIRBAG REPLACEMENT INSTRUCTIONS

I. OPERATION FLOWCHART

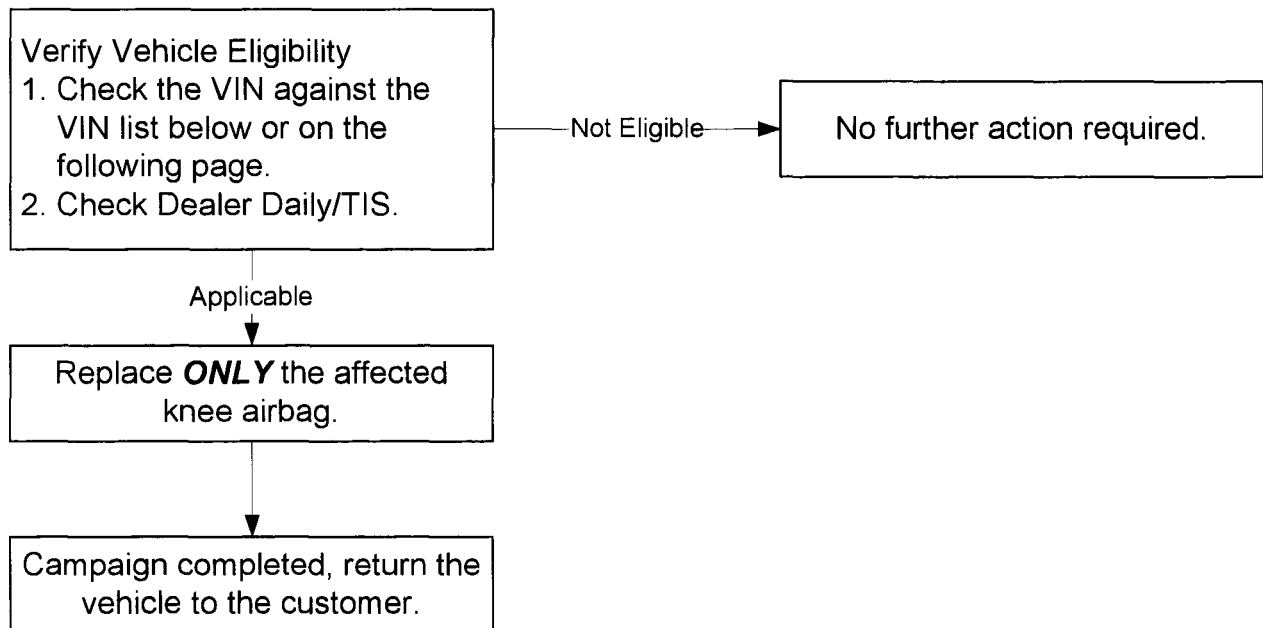

II. BACKGROUND

Due to improper assembly of the airbag inflator, which is incorporated into the SRS airbag assembly (Side Airbag, Curtain Side Airbag or Driver Knee Airbag), some inflators were produced with an insufficient amount of the heating agents necessary for proper airbag deployment. In this condition, the expansion force of the gas may be insufficient to properly inflate the airbag when the SRS system is activated during a collision.

III. IDENTIFICATION OF AFFECTED VEHICLES

A. AFFECTED VEHICLES WITH REPAIR AND PARTS APPLICATION

- **Driver Side Knee Airbag Replacement Only**

Year	VIN	Part Description and Part Number	Qty.
2005	4T1BK36B05U014165	Knee Airbag (Driver Side): 73900-07010-A0	1
	4T1BK36B15U006835	Knee Airbag (Driver Side): 73900-07010-A0	1
	4T1BK36B65U002814	Knee Airbag (Driver Side): 73900-07010-A0	1
	4T1BK36BX5U044323	Knee Airbag (Driver Side): 73900-07010-A0	1
2006	4T1BK36B36U088598	Knee Airbag (Driver Side): 73900-07010-B2	1
	4T1BK36B96U086659	Knee Airbag (Driver Side): 73900-07010-B0	1

IV. PREPARATION

A. TOOLS

- Standard hand tools
- Nylon pry tools
- Torque wrench

V. COMPONENTS

• Driver Side Knee Airbag

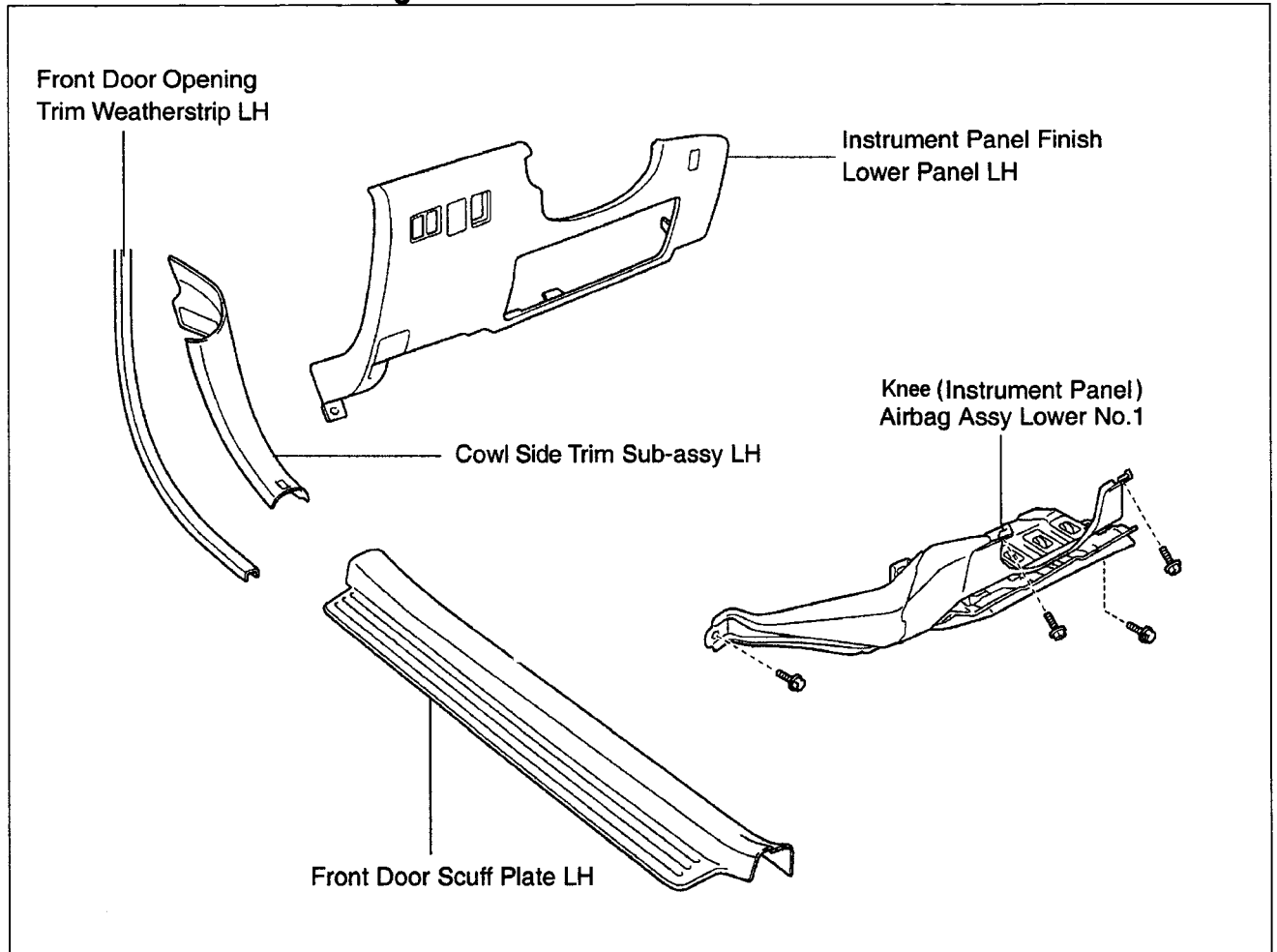

VI. WORK PROCEDURE

NOTE:

Before beginning any work, read and follow ALL the precautions listed in the Supplemental Restraint System: Airbag System: Precaution section of the appropriate Repair Manual for the vehicle you are working on.

NOTE:

Remember to wait at least 90 seconds after the engine switch is turned off and the negative (-) terminal cable is disconnected from the battery before starting work on the SRS system. (The SRS is equipped with a backup power source, so that if work is started within 90 seconds after disconnecting the negative (-) terminal cable of the battery, the SRS may be deployed).

NOTE:

When repairs are complete, inspect the operation of the SRS warning light. Confirm that it goes off approximately 6 seconds after the ignition switch is turned on.

- **DRIVER SIDE KNEE AIRBAG REPLACEMENT PROCEDURE**

- A. Replace the driver knee airbag following the procedures outlined in the Supplemental Restraint System section of the appropriate Repair Manual for the vehicle you are working on.

CAMRY AIRBAG REPLACEMENT INSTRUCTIONS

I. OPERATION FLOWCHART

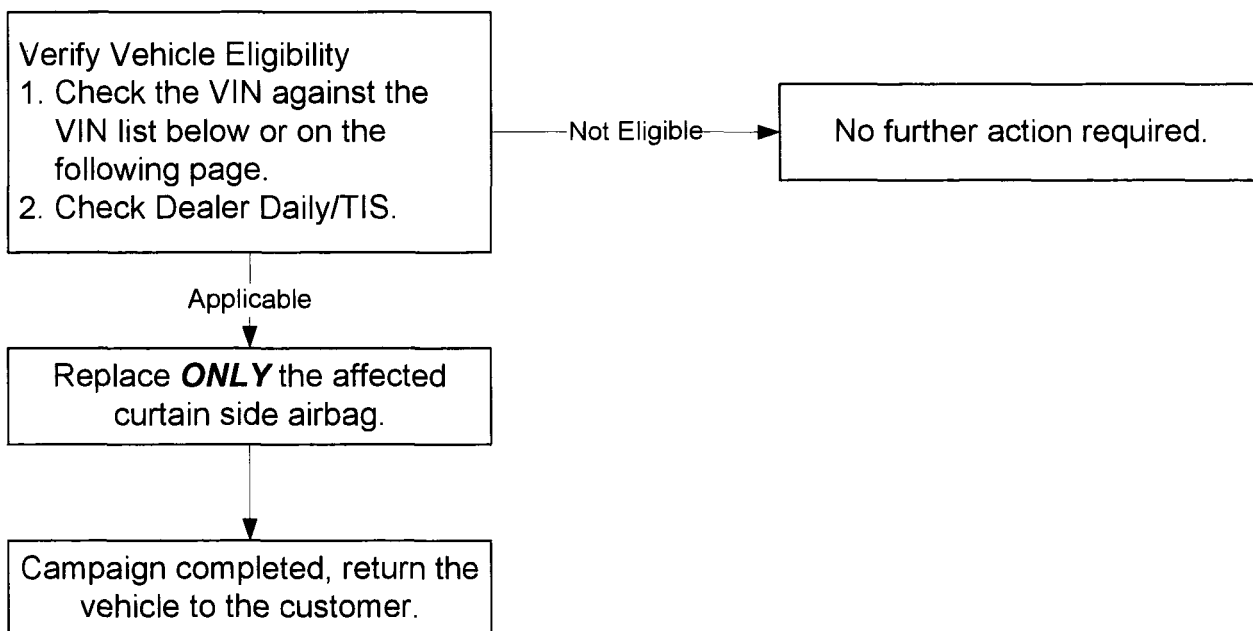

II. BACKGROUND

Due to improper assembly of the airbag inflator, which is incorporated into the SRS airbag assembly (Side Airbag, Curtain Side Airbag or Driver Knee Airbag), some inflators were produced with an insufficient amount of the heating agents necessary for proper airbag deployment. In this condition, the expansion force of the gas may be insufficient to properly inflate the airbag when the SRS system is activated during a collision.

III. IDENTIFICATION OF AFFECTED VEHICLES

A. AFFECTED VEHICLES WITH REPAIR AND PARTS APPLICATION

- **Left Curtain Side Airbag Replacement Only**

Year	VIN	Part Description and Part Number	Qty.
2007	JTNBK46K873000030	Curtain Side Airbag (LH): 62180-33031*	1
		Bolt: 90080-11628	5
		Front Pillar Garnish Clip: 90950-08004	2

NOTE:

* The Curtain Side Airbag assembly includes new clips and spacers.

IV. PREPARATION

A. TOOLS

- Standard hand tools
- Nylon pry tools
- Torque wrench

V. COMPONENTS

- **Curtain Side Airbag**

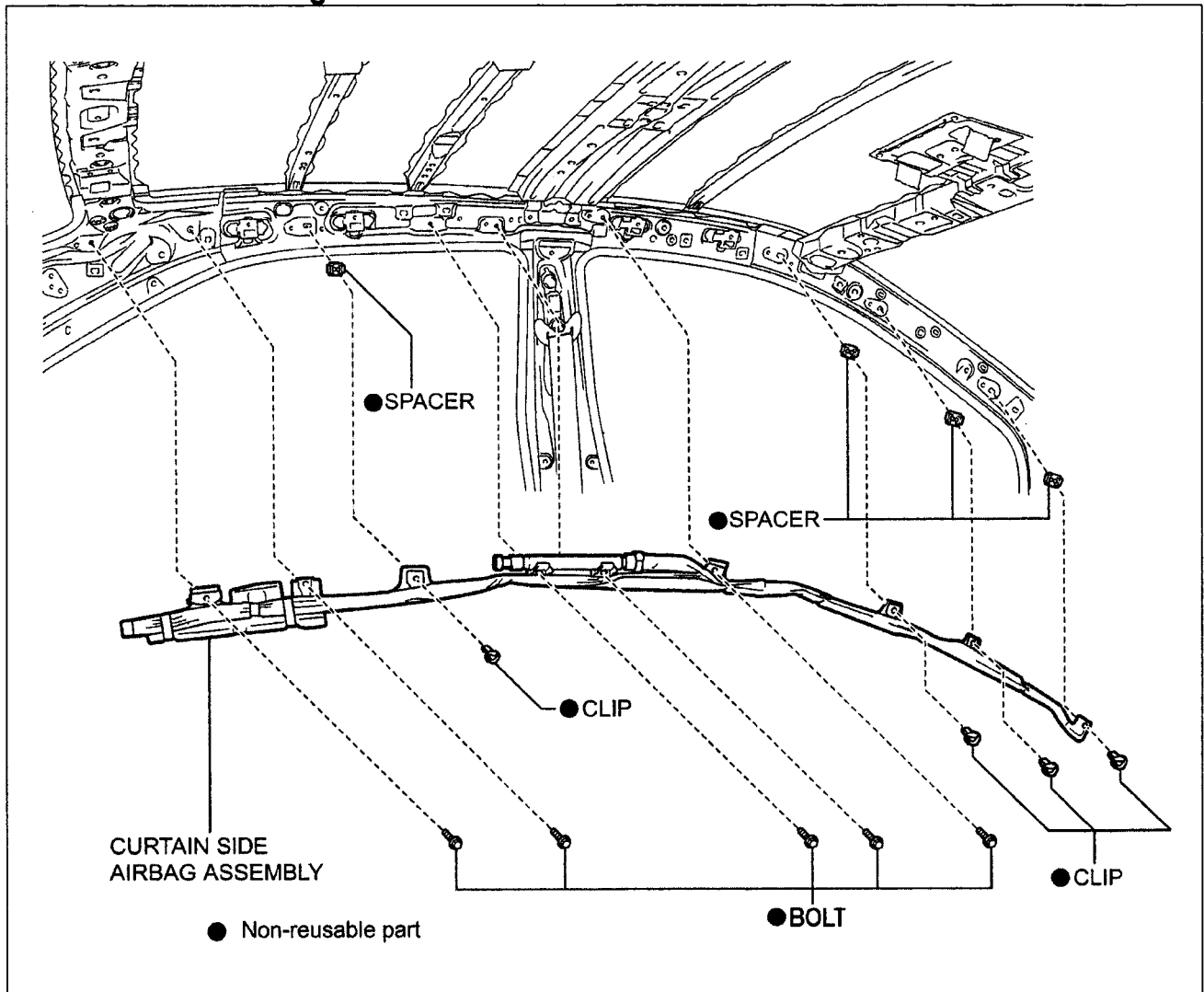

VI. WORK PROCEDURE

NOTE:

Before beginning any work, read and follow ALL the precautions listed in the Supplemental Restraint System: Airbag System: Precaution section of the appropriate Repair Manual for the vehicle you are working on.

NOTE:

Remember to wait at least 90 seconds after the engine switch is turned off and the negative (-) terminal cable is disconnected from the battery before starting work on the SRS system. (The SRS is equipped with a backup power source, so that if work is started within 90 seconds after disconnecting the negative (-) terminal cable of the battery, the SRS may be deployed).

NOTE:

When repairs are complete, inspect the operation of the SRS warning light. Confirm that it goes off approximately 6 seconds after the ignition switch is turned on.

- **CURTAIN SIDE AIRBAG REPLACEMENT PROCEDURE**

- A. Replace the curtain side airbag following the procedures outlined in the Supplemental Restraint System section of the appropriate Repair Manual for the vehicle you are working on.

PRIUS

AIRBAG REPLACEMENT INSTRUCTIONS

I. OPERATION FLOWCHART

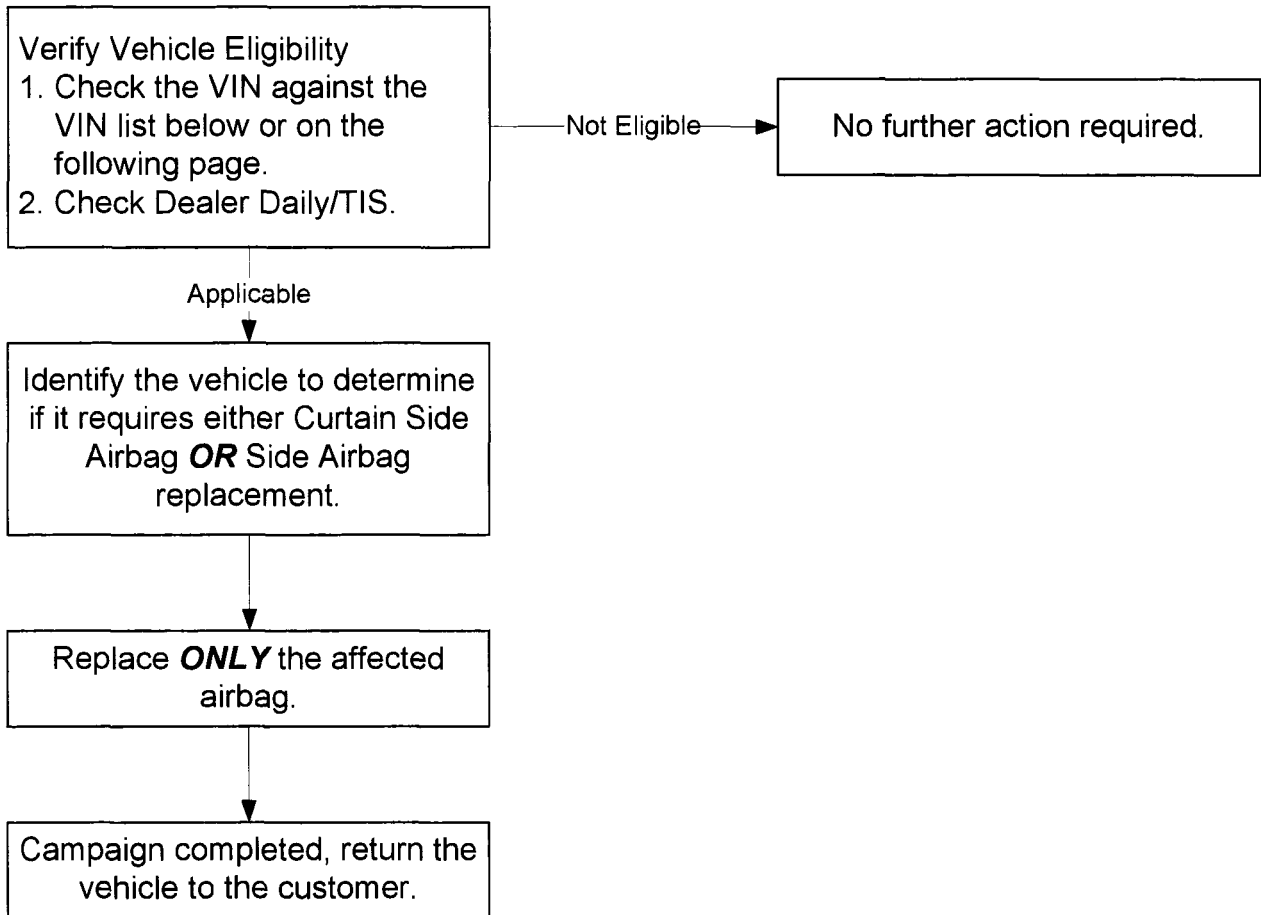

II. BACKGROUND

Due to improper assembly of the airbag inflator, which is incorporated into the SRS airbag assembly (Side Airbag, Curtain Side Airbag or Driver Knee Airbag), some inflators were produced with an insufficient amount of the heating agents necessary for proper airbag deployment. In this condition, the expansion force of the gas may be insufficient to properly inflate the airbag when the SRS system is activated during a collision.

III. IDENTIFICATION OF AFFECTED VEHICLES

A. AFFECTED VEHICLES WITH REPAIR AND PARTS APPLICATION

- Left Curtain Side Airbag Replacement Only

Year	VIN	Part Description and Part Number	Qty.	
2004	JTDKB20U540025760	Curtain Side Airbag (LH): 62180-47010	1	
		Front Pillar Garnish Clip: 90950-08004	2	
	JTDKB20U040009577	Curtain Side Airbag (LH): 62180-47010	1	
		Front Pillar Garnish Clip: 90950-08004	2	
	JTDKB20U440024826	Curtain Side Airbag (LH): 62180-47010	1	
		Front Pillar Garnish Clip: 90950-08004	2	
	JTDKB20U340032190	Curtain Side Airbag (LH): 62180-47010	1	
		Front Pillar Garnish Clip: 90950-08004	2	
	JTDKB20U140028512	Curtain Side Airbag (LH): 62180-47010	1	
		Front Pillar Garnish Clip: 90950-08004	2	
	2005	JTDKB20U453098876	Curtain Side Airbag (LH): 62180-47010	1
			Front Pillar Garnish Clip: 90950-08004	2
JTDKB20U553036838		Curtain Side Airbag (LH): 62180-47010	1	
		Front Pillar Garnish Clip: 90950-08004	2	
JTDKB20UX57010518		Curtain Side Airbag (LH): 62180-47010	1	
		Front Pillar Garnish Clip: 90950-08004	2	
JTDKB20U953094452		Curtain Side Airbag (LH): 62180-47010	1	
		Front Pillar Garnish Clip: 90950-08004	2	
JTDKB20U853119938		Curtain Side Airbag (LH): 62180-47010	1	
		Front Pillar Garnish Clip: 90950-08004	2	
JTDKB20U753122930		Curtain Side Airbag (LH): 62180-47010	1	
		Front Pillar Garnish Clip: 90950-08004	2	
2006	JTDKB20U163132824	Curtain Side Airbag (LH): 62180-47010	1	
		Front Pillar Garnish Clip: 90950-08004	2	
	JTDKB20U967062840	Curtain Side Airbag (LH): 62180-47010	1	
		Front Pillar Garnish Clip: 90950-08004	2	
	JTDKB20U763134951	Curtain Side Airbag (LH): 62180-47010	1	
		Front Pillar Garnish Clip: 90950-08004	2	
	JTDKB20U763135307	Curtain Side Airbag (LH): 62180-47010	1	
		Front Pillar Garnish Clip: 90950-08004	2	

[Identification of Affected Vehicles Continued...]

• **Right Curtain Side Airbag Replacement Only**

Year	VIN	Part Description and Part Number	Qty.
2004	JTDKB20U740032113	Curtain Side Airbag (RH): 62170-47010	1
		Front Pillar Garnish Clip: 90950-08004	2
2005	JTDKB20U353038281	Curtain Side Airbag (RH): 62170-47010	1
		Front Pillar Garnish Clip: 90950-08004	2
	JTDKB20U453107673	Curtain Side Airbag (RH): 62170-47010	1
		Front Pillar Garnish Clip: 90950-08004	2
	JTDKB20U453021425	Curtain Side Airbag (RH): 62170-47010	1
		Front Pillar Garnish Clip: 90950-08004	2
	JTDKB20U353056361	Curtain Side Airbag (RH): 62170-47010	1
		Front Pillar Garnish Clip: 90950-08004	2
	JTDKB20U553003208	Curtain Side Airbag (RH): 62170-47010	1
		Front Pillar Garnish Clip: 90950-08004	2
	JTDKB20U253119563	Curtain Side Airbag (RH): 62170-47010	1
		Front Pillar Garnish Clip: 90950-08004	2
	JTDKB20U253117005	Curtain Side Airbag (RH): 62170-47010	1
		Front Pillar Garnish Clip: 90950-08004	2
	JTDKB20U153099693	Curtain Side Airbag (RH): 62170-47010	1
		Front Pillar Garnish Clip: 90950-08004	2
	JTDKB20U053057239	Curtain Side Airbag (RH): 62170-47010	1
		Front Pillar Garnish Clip: 90950-08004	2
	JTDKB20U757043153	Curtain Side Airbag (RH): 62170-47010	1
		Front Pillar Garnish Clip: 90950-08004	2
JTDKB20U753119574	Curtain Side Airbag (RH): 62170-47010	1	
	Front Pillar Garnish Clip: 90950-08004	2	
JTDKB20U553120318	Curtain Side Airbag (RH): 62170-47010	1	
	Front Pillar Garnish Clip: 90950-08004	2	
JTDKB20U753099407	Curtain Side Airbag (RH): 62170-47010	1	
	Front Pillar Garnish Clip: 90950-08004	2	
2006	JTDKB20UX63133342	Curtain Side Airbag (RH): 62170-47010	1
		Front Pillar Garnish Clip: 90950-08004	2
	JTDKB20U163137165	Curtain Side Airbag (RH): 62170-47010	1
		Front Pillar Garnish Clip: 90950-08004	2
	JTDKB20U363135028	Curtain Side Airbag (RH): 62170-47010	1
		Front Pillar Garnish Clip: 90950-08004	2
JTDKB20U867061372	Curtain Side Airbag (RH): 62170-47010	1	
	Front Pillar Garnish Clip: 90950-08004	2	

[Identification of Affected Vehicles Continued...]

• **Left Side Airbag Replacement Only**

Year	VIN	Part Description and Part Number	Qty.
2005	JTDKB20U657047114	Side Airbag (LH): 71200-47151-B1	1
	JTDKB20U953107684	Side Airbag (LH): 71200-47151-A1	1
	JTDKB20U253107221	Side Airbag (LH): 71200-47151-A1	1
	JTDKB20U753107358	Side Airbag (LH): 71200-47151-A1	1
	JTDKB20U453107527	Side Airbag (LH): 71200-47151-A1	1
	JTDKB20U553106533	Side Airbag (LH): 71200-47151-A1	1
	JTDKB20U557047136	Side Airbag (LH): 71200-47151-B1	1
2006	JTDKB20U063134676	Side Airbag (LH): 71200-47240-B1	1

• **Right Side Airbag Replacement Only**

Year	VIN	Part Description and Part Number	Qty.
2005	JTDKB20U057047416	Side Airbag (RH): 71100-47161-B1	1
	JTDKB20UX53005973	Side Airbag (RH): 71100-47161-B1	1
	JTDKB20U557025184	Side Airbag (RH): 71100-47161-B1	1
	JTDKB20U457046916	Side Airbag (RH): 71100-47161-A1	1
	JTDKB20U453032912	Side Airbag (RH): 71100-47161-A1	1

IV. PREPARATION

A. TOOLS

- Standard hand tools
- Nylon pry tools
- Torque wrench

V. COMPONENTS

- **Curtain Side Airbag**

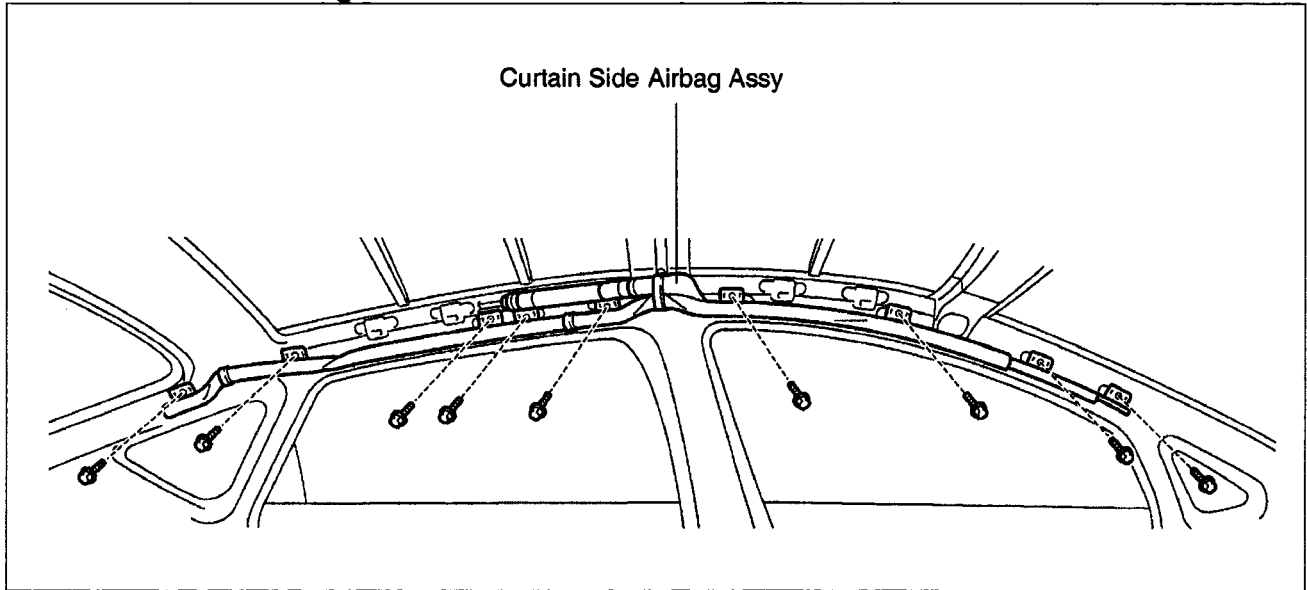

- **Side Airbag**

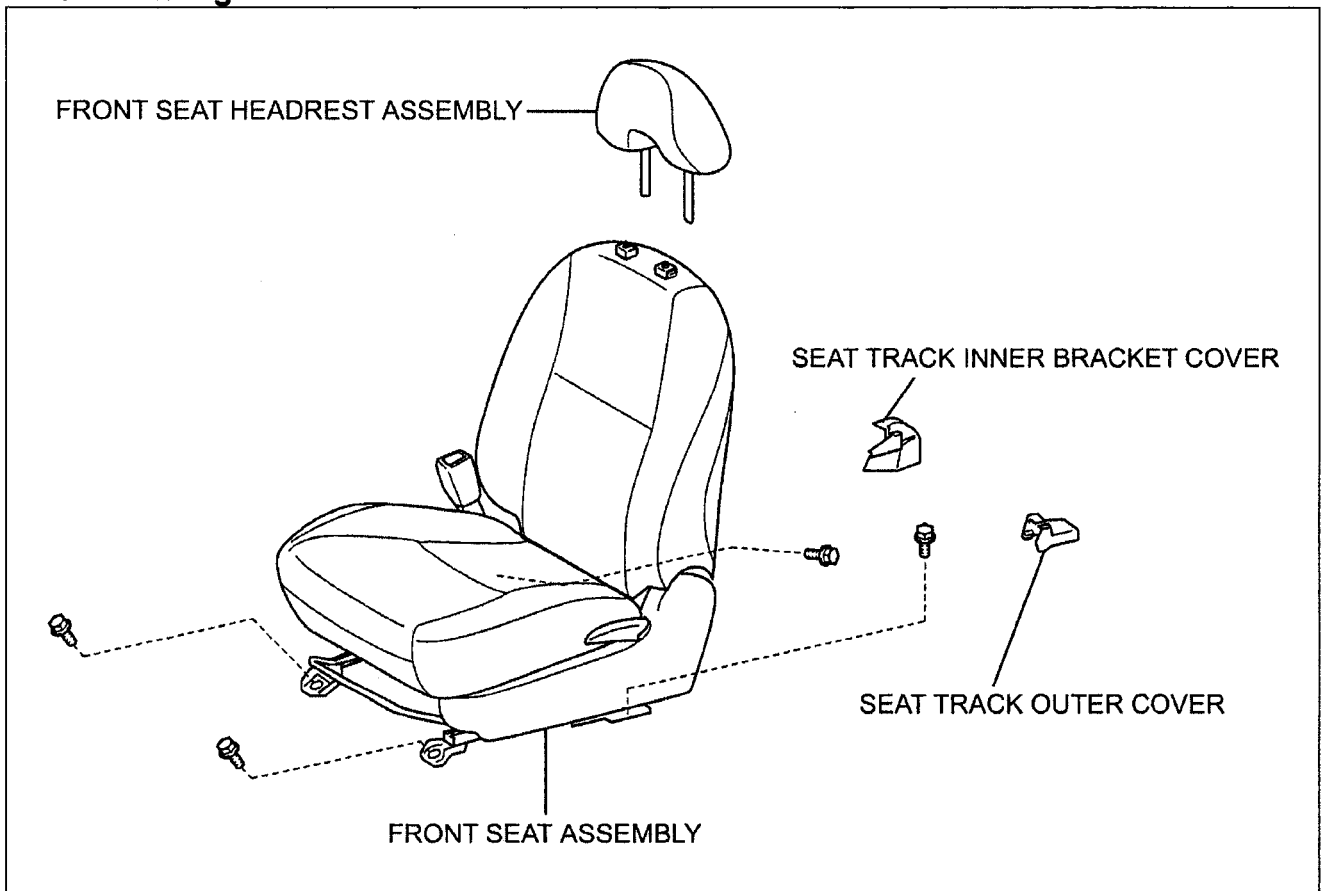

VI. WORK PROCEDURE

NOTE:

Before beginning any work, read and follow ALL the precautions listed in the appropriate section of the Repair Manual for the vehicle you are working on.

- For 2004 and 2005 refer to the Supplemental Restraint System: Supplemental Restraint System: Precaution section.
- For 2006 refer to the Supplemental Restraint System: Airbag System: Precaution section.

NOTE:

Remember to wait at least 90 seconds after the engine switch is turned off and the negative (-) terminal cable is disconnected from the battery before starting work on the SRS system. (The SRS is equipped with a backup power source, so that if work is started within 90 seconds after disconnecting the negative (-) terminal cable of the battery, the SRS may be deployed).

NOTE:

When repairs are complete, inspect the operation of the SRS warning light. Confirm that it goes off approximately 6 seconds after the ignition switch is turned on.

- **CURTAIN SIDE AIRBAG REPLACEMENT PROCEDURE**

- A. Replace the curtain side airbag following the procedures outlined in the Supplemental Restraint System section of the appropriate Repair Manual for the vehicle you are working on.

- **SIDE AIRBAG REPLACEMENT PROCEDURE**

- A. Replace the side airbag following the procedures outlined in the Seat: Front Seat section of the appropriate Repair Manual for the vehicle you are working on.

NOTE:

To replace the side airbag, the entire seat must be replaced.

RAV4 AIRBAG REPLACEMENT INSTRUCTIONS

I. OPERATION FLOWCHART

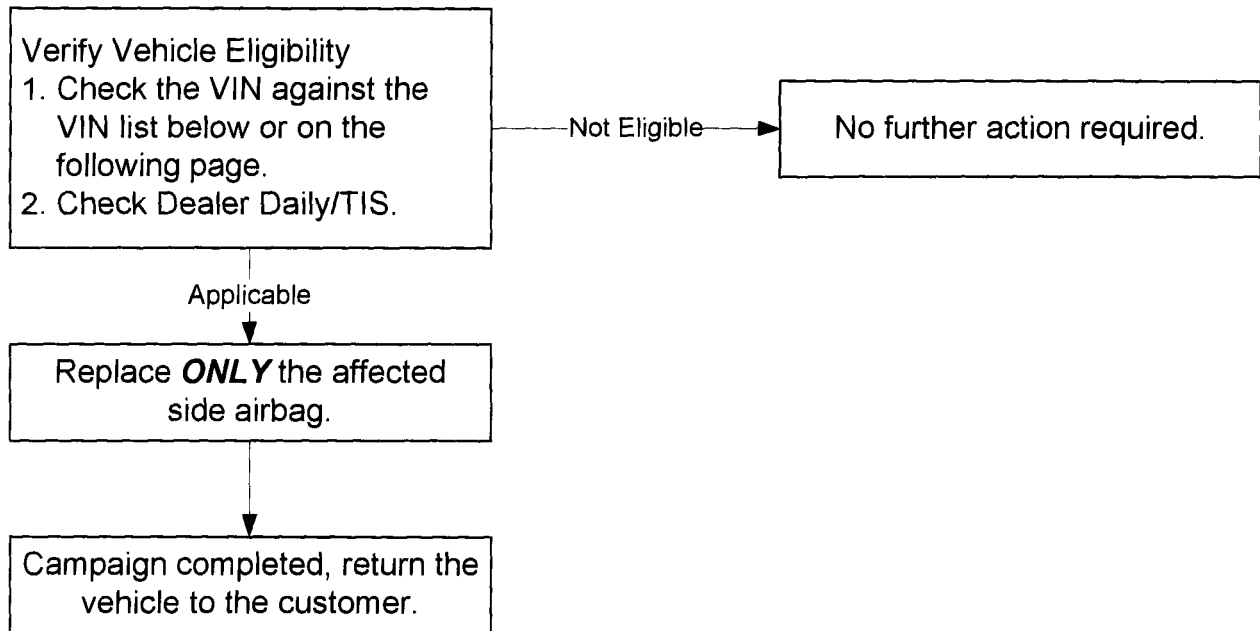

II. BACKGROUND

Due to improper assembly of the airbag inflator, which is incorporated into the SRS airbag assembly (Side Airbag, Curtain Side Airbag or Driver Knee Airbag), some inflators were produced with an insufficient amount of the heating agents necessary for proper airbag deployment. In this condition, the expansion force of the gas may be insufficient to properly inflate the airbag when the SRS system is activated during a collision.

III. IDENTIFICATION OF AFFECTED VEHICLES

A. AFFECTED VEHICLES WITH REPAIR AND PARTS APPLICATION

- **Left Side Airbag Replacement Only**

Year	VIN	Part Description and Part Number	Qty.
2005	JTEHD20V556044476	Side Airbag (LH): 71200-42A90-E0	1

IV. PREPARATION

A. TOOLS

- Standard hand tools
- Nylon pry tools
- Torque wrench

V. COMPONENTS

- Side Airbag

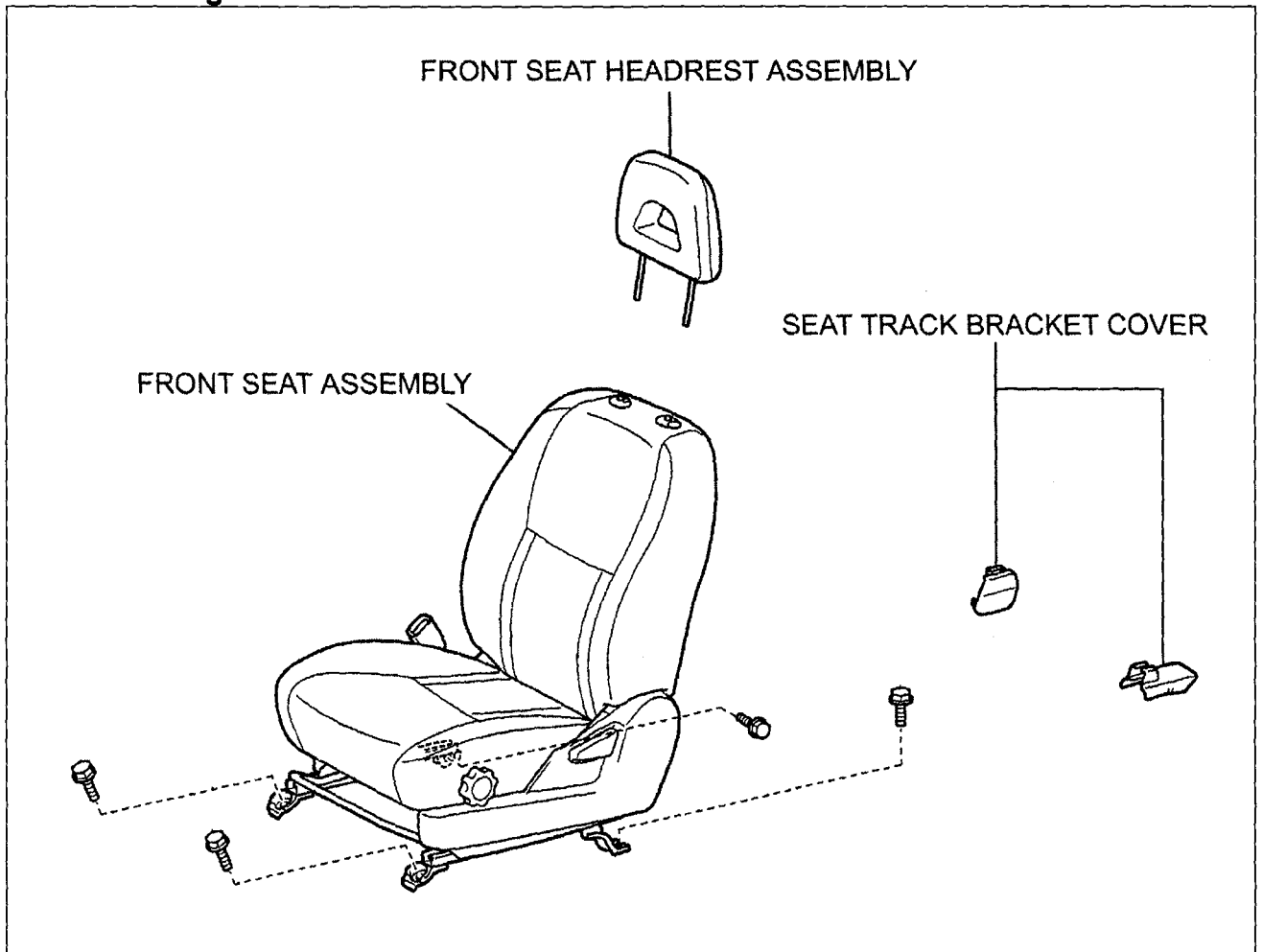

VI. WORK PROCEDURE

NOTE:

Before beginning any work, read and follow ALL the precautions listed in the Supplemental Restraint System: SRS Airbag: Precaution section of the appropriate Repair Manual for the vehicle you are working on.

NOTE:

Remember to wait at least 90 seconds after the engine switch is turned off and the negative (-) terminal cable is disconnected from the battery before starting work on the SRS system. (The SRS is equipped with a backup power source, so that if work is started within 90 seconds after disconnecting the negative (-) terminal cable of the battery, the SRS may be deployed).

NOTE:

When repairs are complete, inspect the operation of the SRS warning light. Confirm that it goes off approximately 6 seconds after the ignition switch is turned on.

- **SIDE AIRBAG REPLACEMENT PROCEDURE**

- A. Replace the side airbag following the procedures outlined in the Body: Front Seat section of the appropriate Repair Manual for the vehicle you are working on.

NOTE:

To replace the side airbag, the entire seat must be replaced.

SCION tC AIRBAG REPLACEMENT INSTRUCTIONS

I. OPERATION FLOWCHART

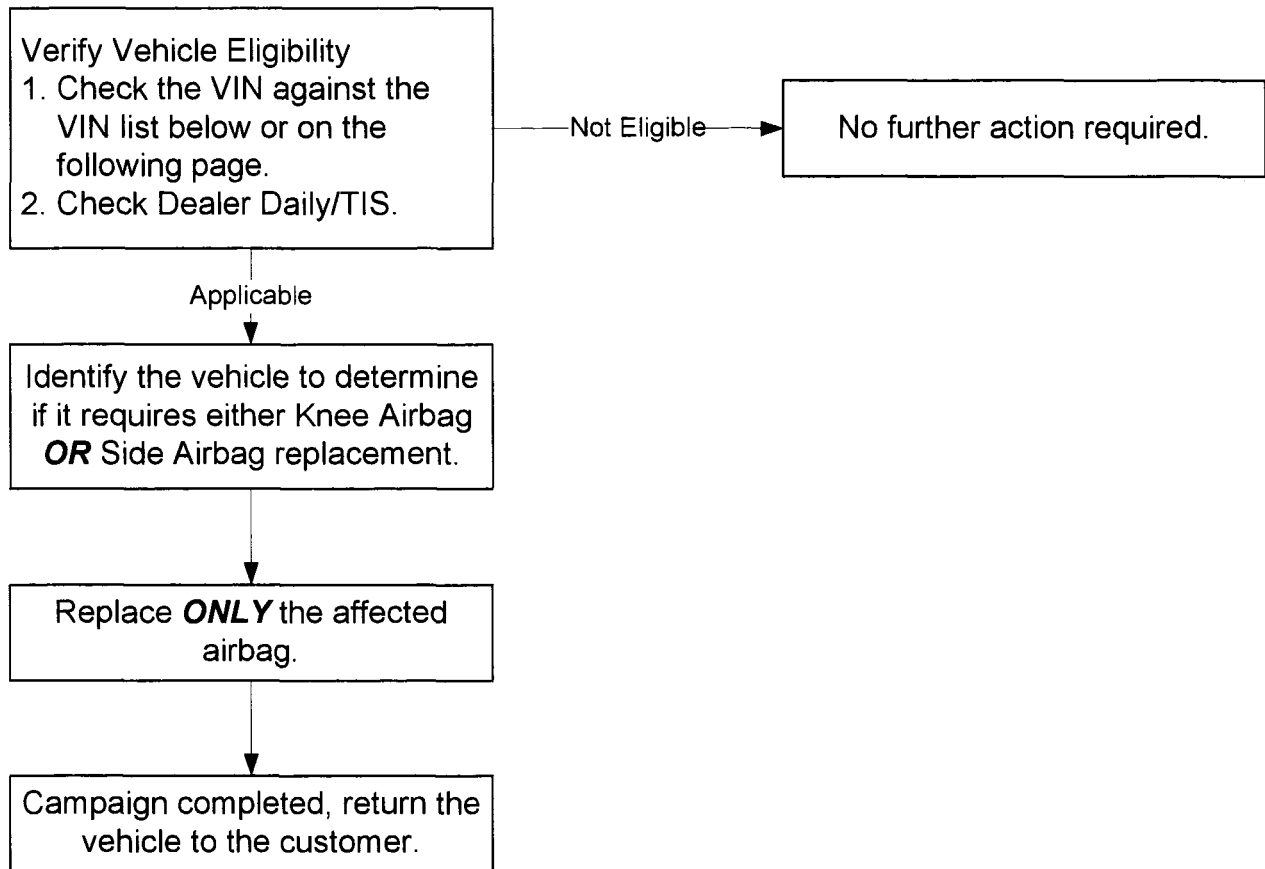

II. BACKGROUND

Due to improper assembly of the airbag inflator, which is incorporated into the SRS airbag assembly (Side Airbag, Curtain Side Airbag or Driver Knee Airbag), some inflators were produced with an insufficient amount of the heating agents necessary for proper airbag deployment. In this condition, the expansion force of the gas may be insufficient to properly inflate the airbag when the SRS system is activated during a collision.

III. IDENTIFICATION OF AFFECTED VEHICLES

A. AFFECTED VEHICLES WITH REPAIR AND PARTS APPLICATION

- **Driver Side Knee Airbag Replacement Only**

Year	VIN	Part Description and Part Number	Qty.
2005	JTKDE177150005378	Knee Airbag (Driver Side): 73900-21020-B0	1
	JTKDE177350020190	Knee Airbag (Driver Side): 73900-21020-B0	1
	JTKDE177450043655	Knee Airbag (Driver Side): 73900-21020-B0	1
	JTKDE177450057216	Knee Airbag (Driver Side): 73900-21020-B0	1
2006	JTKDE167060089521	Knee Airbag (Driver Side): 73900-21020-B0	1
	JTKDE167960086083	Knee Airbag (Driver Side): 73900-21020-B0	1
	JTKDE167960086987	Knee Airbag (Driver Side): 73900-21020-B0	1
	JTKDE167X60102632	Knee Airbag (Driver Side): 73900-21020-B0	1
	JTKDE177060083247	Knee Airbag (Driver Side): 73900-21020-B0	1
	JTKDE177060086763	Knee Airbag (Driver Side): 73900-21020-B0	1
	JTKDE177060107644	Knee Airbag (Driver Side): 73900-21020-B0	1
	JTKDE177160089347	Knee Airbag (Driver Side): 73900-21020-B0	1
	JTKDE177560086256	Knee Airbag (Driver Side): 73900-21020-B0	1
	JTKDE177660086007	Knee Airbag (Driver Side): 73900-21020-B0	1
	JTKDE177960098054	Knee Airbag (Driver Side): 73900-21020-B0	1
	JTKDE177960098197	Knee Airbag (Driver Side): 73900-21020-B0	1

- **Right Side Airbag Replacement Only**

Year	VIN	Part Description and Part Number	Qty.
2006	JTKDE167960087296	Side Airbag (RH): 71100-21670-B1	1

IV. PREPARATION

A. TOOLS

- Standard hand tools
- Nylon pry tools
- Torque wrench

V. COMPONENTS

- Driver Side Knee Airbag

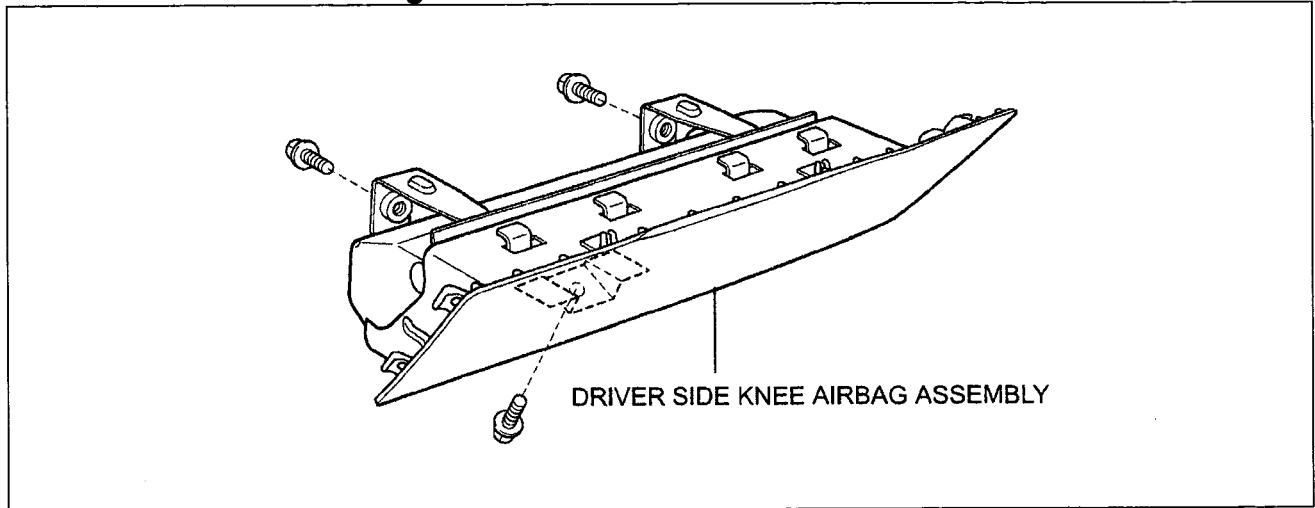

- Side Airbag

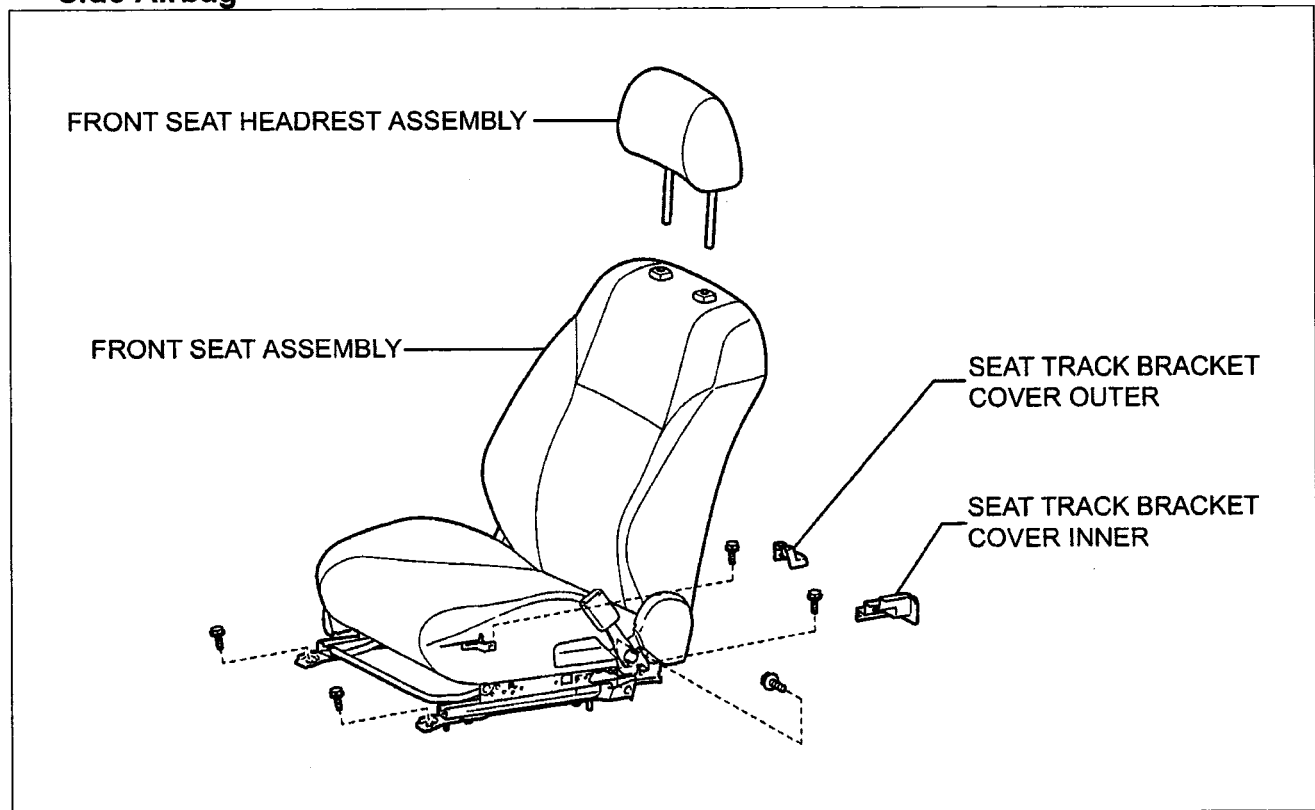

VI. WORK PROCEDURE

NOTE:

Before beginning any work, read and follow ALL the precautions listed in the appropriate section of the Repair Manual for the vehicle you are working on.

- For 2005 refer to the Supplemental Restraint System: Supplemental Restraint System: Precaution section.
- For 2006 refer to the Supplemental Restraint System: Airbag System: Precaution section.

NOTE:

Remember to wait at least 90 seconds after the engine switch is turned off and the negative (-) terminal cable is disconnected from the battery before starting work on the SRS system. (The SRS is equipped with a backup power source, so that if work is started within 90 seconds after disconnecting the negative (-) terminal cable of the battery, the SRS may be deployed).

NOTE:

When repairs are complete, inspect the operation of the SRS warning light. Confirm that it goes off approximately 6 seconds after the ignition switch is turned on.

• DRIVER SIDE KNEE AIRBAG REPLACEMENT PROCEDURE

- A. Replace the driver knee airbag following the procedures outlined in the Supplemental Restraint System section of the appropriate Repair Manual for the vehicle you are working on.

• SIDE AIRBAG REPLACEMENT PROCEDURE

- A. Replace the side airbag following the procedures outlined in the Seat: Front Seat section of the appropriate Repair Manual for the vehicle you are working on.

NOTE:

To replace the side airbag, the entire seat must be replaced.

TACOMA

AIRBAG REPLACEMENT INSTRUCTIONS

I. OPERATION FLOWCHART

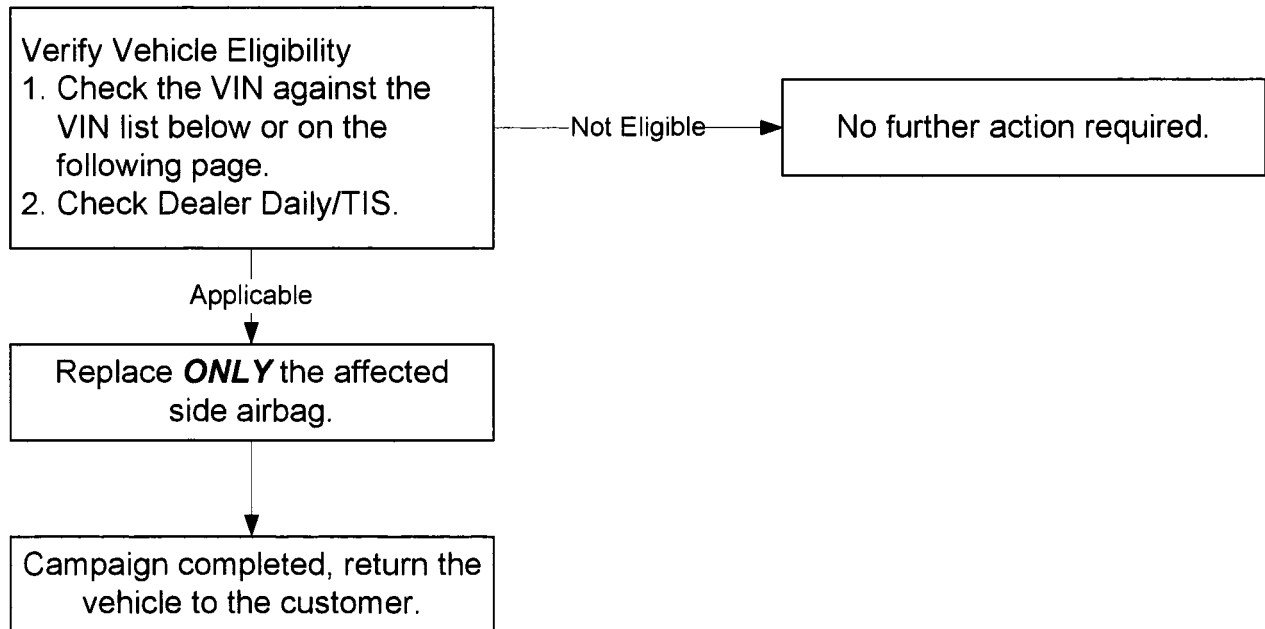

II. BACKGROUND

Due to improper assembly of the airbag inflator, which is incorporated into the SRS airbag assembly (Side Airbag, Curtain Side Airbag or Driver Knee Airbag), some inflators were produced with an insufficient amount of the heating agents necessary for proper airbag deployment. In this condition, the expansion force of the gas may be insufficient to properly inflate the airbag when the SRS system is activated during a collision.

III. IDENTIFICATION OF AFFECTED VEHICLES

A. AFFECTED VEHICLES WITH REPAIR AND PARTS APPLICATION

- **Left Side Airbag Replacement Only**

Year	VIN	Part Description and Part Number	Qty.
2005	5TELU42N75Z081376	Side Airbag (LH): 71200-AD070-B3	1
2006	5TELU42N96Z190357	Side Airbag (LH): 71200-AD070-B3	1

IV. PREPARATION

A. TOOLS

- Standard hand tools
- Nylon pry tools
- Torque wrench

V. COMPONENTS

- Side Airbag

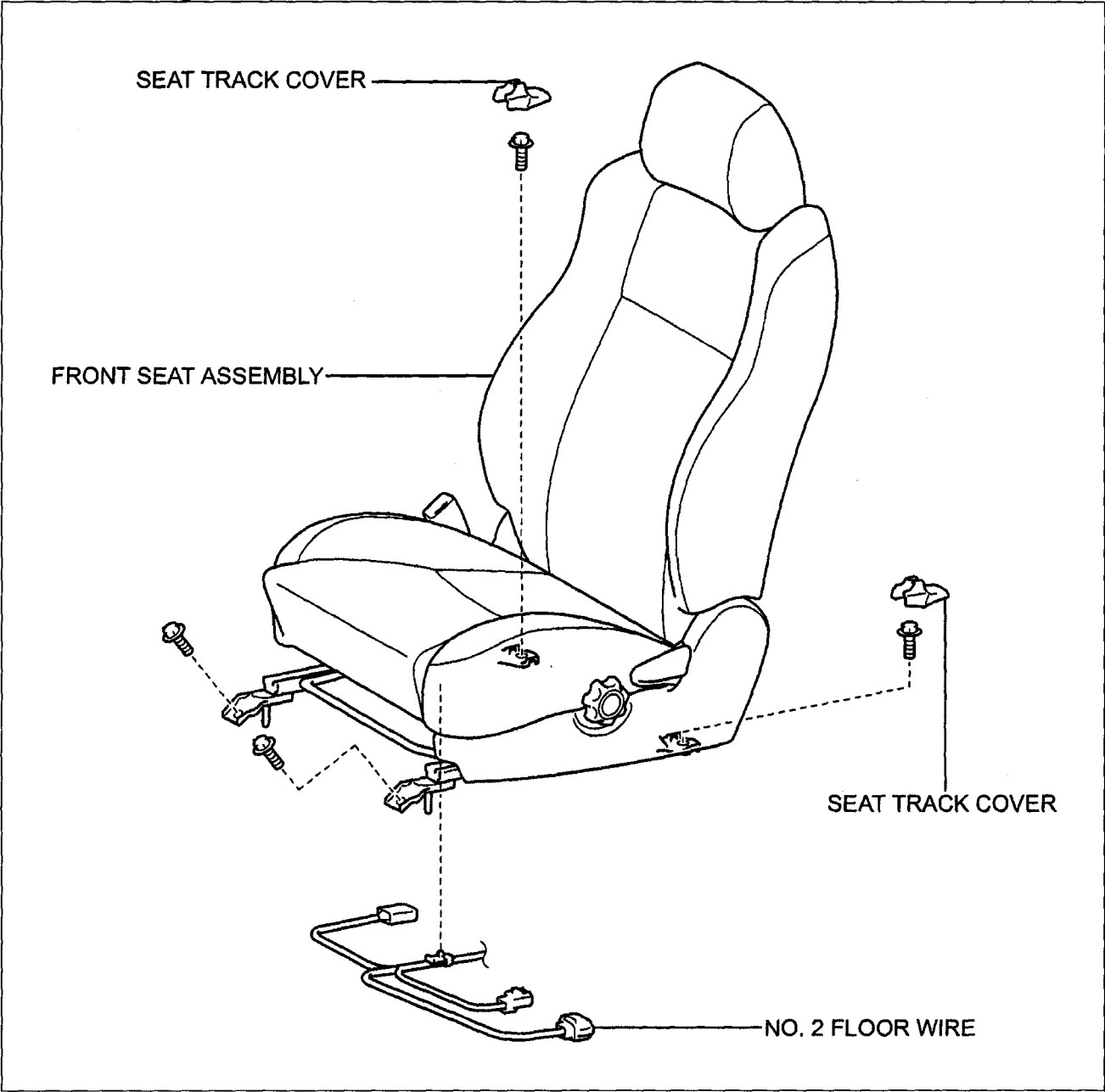

VI. WORK PROCEDURE

NOTE:

Before beginning any work, read and follow ALL the precautions listed in the appropriate section of the Repair Manual for the vehicle you are working on.

- For 2005 refer to the Supplemental Restraint System: Supplemental Restraint System: Precaution section.
- For 2006 refer to the Supplemental Restraint System: Airbag System: Precaution section.

NOTE:

Remember to wait at least 90 seconds after the engine switch is turned off and the negative (-) terminal cable is disconnected from the battery before starting work on the SRS system. (The SRS is equipped with a backup power source, so that if work is started within 90 seconds after disconnecting the negative (-) terminal cable of the battery, the SRS may be deployed).

NOTE:

When repairs are complete, inspect the operation of the SRS warning light. Confirm that it goes off approximately 6 seconds after the ignition switch is turned on.

• SIDE AIRBAG REPLACEMENT PROCEDURE

- A. Replace the side airbag following the procedures outlined in the Seat: Front Seat section of the appropriate Repair Manual for the vehicle you are working on.

NOTE:

To replace the side airbag, the entire seat must be replaced.

UNDEPLOYED AIRBAG DISPOSAL INSTRUCTIONS

Undeployed airbags are considered hazardous waste that must be disposed of in the proper manner according to local, state, and federal regulations for hazmat waste. In most states the undeployed airbag will need to be picked up for disposal by a Hazmat disposal company.