

# NISSAN

---

**NISSAN NORTH AMERICA, INC.**

Corporate Office  
18501 South Figueroa St.  
Gardena, California 90248-4500  
Mailing Address: P.O. Box 191  
Gardena, California 90248-0191  
Telephone: 310.532.3111

March 20, 2006

Mr. George Person  
Chief, Recall Analysis Division  
Office of Defects Investigation  
Safety Assurance  
National Highway Traffic Safety Administration  
400 Seventh Street, S.W.  
Washington, D.C. 20590

Ref: 06V-054

Dear Mr. Person:

The enclosed communication is being provided pursuant to 49 CFR Part 573.6(c)(9).

Technical Compliance Department

Encl.

RECEIVED  
2006 MAR 22 P 3:01  
OFFICE OF DEFECTS  
INVESTIGATION



# RECALL CAMPAIGN BULLETIN

Reference: NTB06-025	Date: March 17, 2006
-------------------------	-------------------------

## VOLUNTARY RECALL CAMPAIGN 2005 MURANO FUEL TANK REPLACEMENT

**CAMPAIGN I.D. # / NHTSA #: R0601 / 06V-54**

**APPLIED VEHICLES:** 2005 Murano (Z50)

**APPLIED VINS:** JN8AZ08T(\*)5W 316465 to 322411 (2WD models)  
JN8AZ08W(\*)5W 424621 to 433572 (AWD models)

**NOTE: Use Service Comm to confirm campaign eligibility.**

### INTRODUCTION

Nissan has determined that some 2005 model year Nissan Murano vehicles may have a defect which relates to motor vehicle safety. There is the possibility that a vapor hose fitting attached to the fuel tank may come off. This will result in the malfunction indicator lamp (MIL) in the instrument panel coming on and may result in some fuel leakage. If an ignition source is present, a fire could occur. To prevent this condition from occurring, Nissan is conducting a Voluntary Safety Recall Campaign to replace the fuel tank with a new one free of charge.

### IDENTIFICATION NUMBER

Nissan has assigned identification number 06V-54 to this campaign. This number must appear on all communications and documentation of any nature dealing with this campaign.

### NUMBER OF VEHICLES POTENTIALLY AFFECTED

The number of vehicles potentially affected is approximately 14,268.

### DEALER RESPONSIBILITY

It is the retailer's responsibility to check Service Comm for the campaign status on each vehicle falling within the range of this voluntary safety recall which for any reason enters the service department. This includes vehicles purchased from private parties or presented by transient (tourist) owners and vehicles in a dealer's inventory. **Federal law requires that new vehicles in dealer inventory which are the subject of a safety recall must be corrected prior to delivery under a sale or lease. Failure to do so can result in civil penalties by the National Highway Traffic Safety Administration.** While federal law applies only to new vehicles, Nissan strongly encourages dealers to correct any used vehicles in their inventory before they are retailed.

## Repair Overview

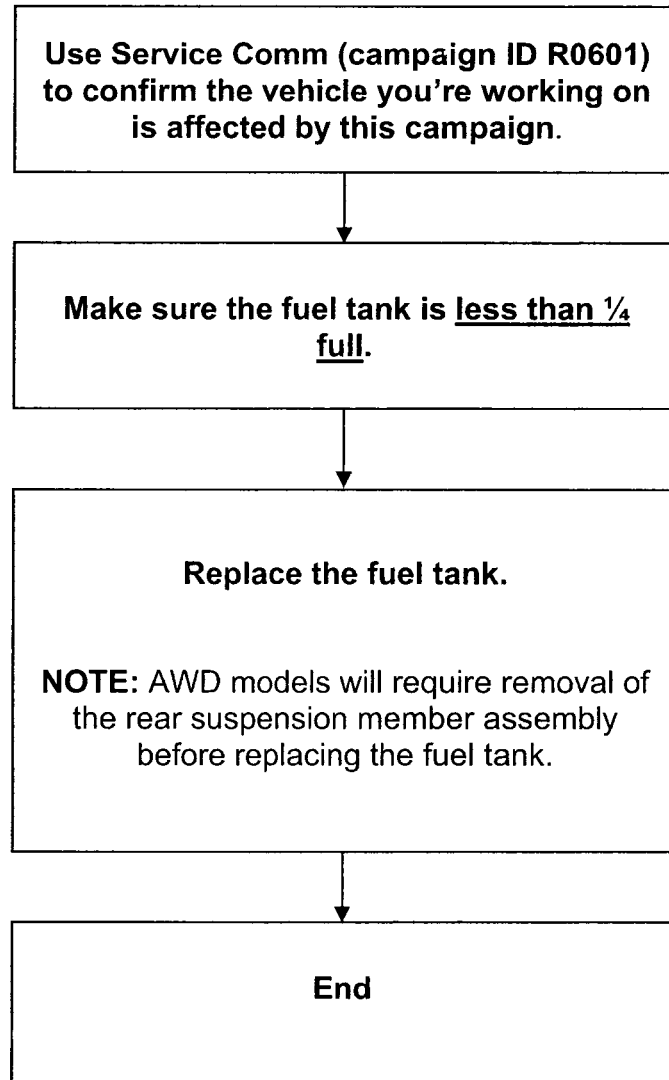

**REQUIRED PARTS**

Refer to Parts Information for the part numbers.

- Fuel Tank Kit; Figure 1a.

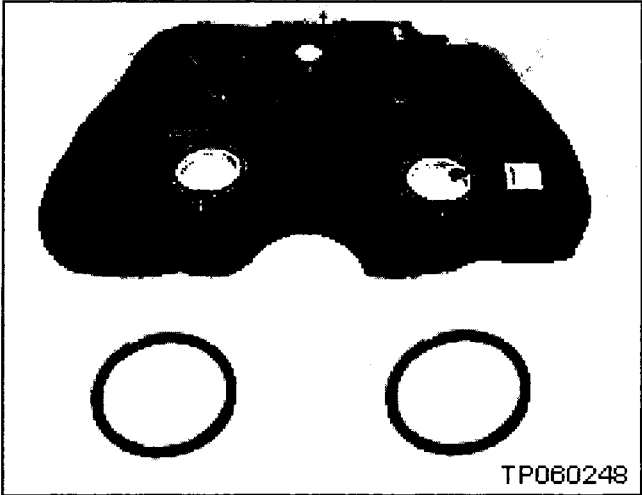

Figure 1a

- Propeller shaft bolt kit; Figure 1b.  
(AWD models only)

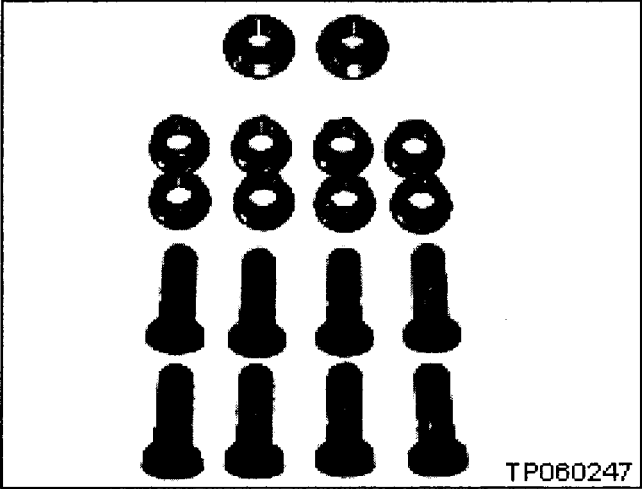

Figure 1b

- Exhaust tube gaskets; Figure 1c.

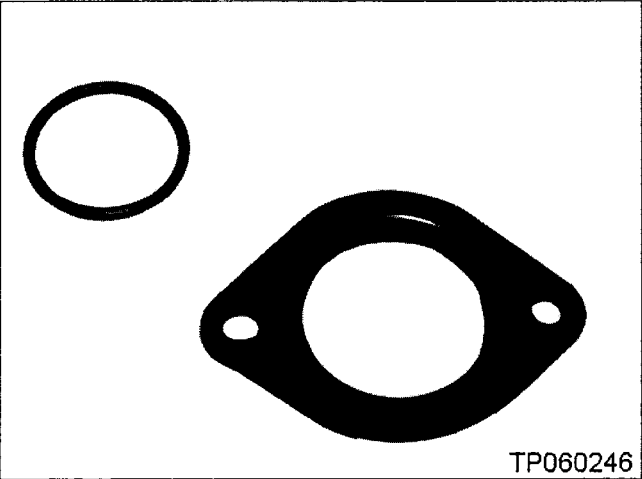

Figure 1c

## REQUIRED SPECIAL TOOL

Essential tool J-46211 (Fuel Tank Lock Ring Wrench) is required for the procedure in this bulletin.

This special tool was assigned to drawer # 6 in the Special Tool Storage System (STSS).

Replacement tools can be ordered from Nissan TECH-MATE at 1-800-662-2001—option 1.

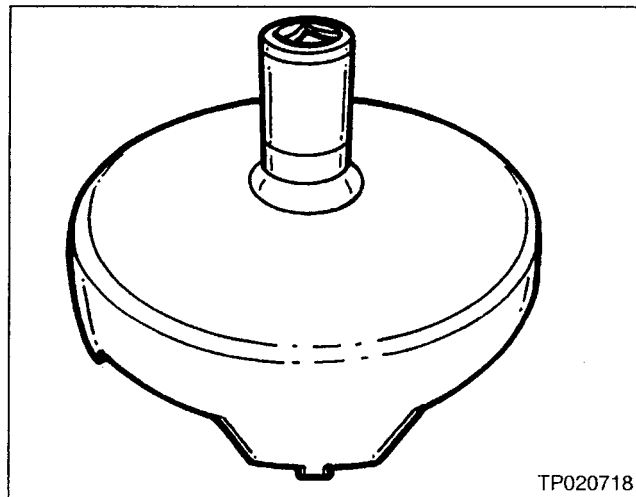

Figure 1d

## SERVICE PROCEDURE

**IMPORTANT:** The fuel tank must be **less than ¼ full** before starting this procedure.

### Preliminary Steps (2WD and AWD vehicles)

1. Release the fuel pressure.
  - a. Remove the 15A fuel pump fuse.
  - b. Start the engine and let it run until it stops.
  - c. Crank the engine 3 times for 3 seconds each time. This will release all fuel pressure.
  - d. Turn the ignition OFF.
  - e. Reinstall the fuel pump fuse.

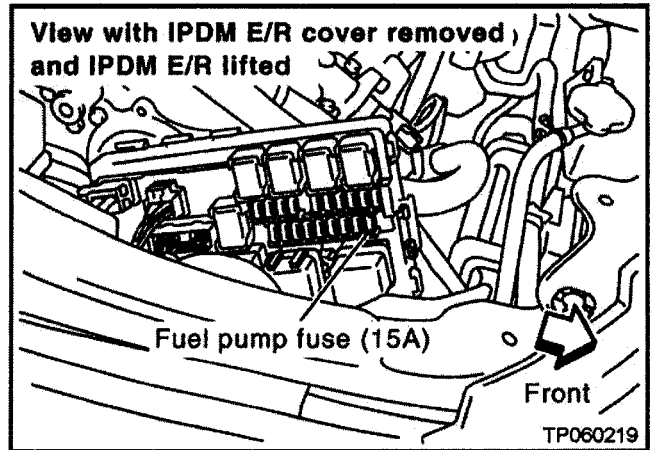

Figure 2

2. Record all radio station presets.
3. Disconnect the negative battery cable.
4. Remove the trim covers at the front of the left rear seat cushion (driver side).

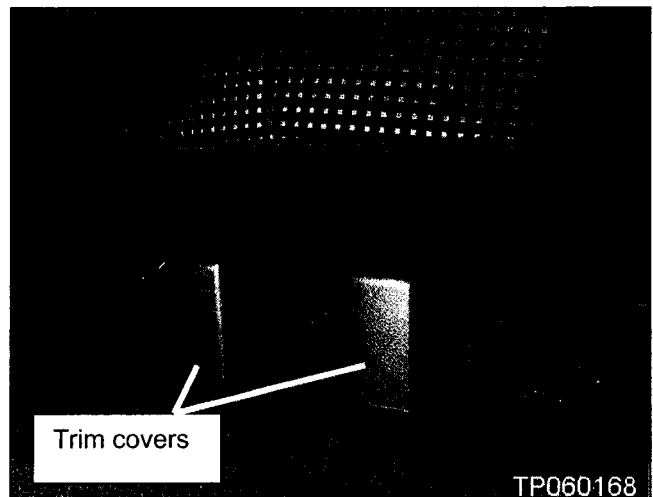

Figure 3

5. Remove the bolts from the front of the left rear seat cushion.

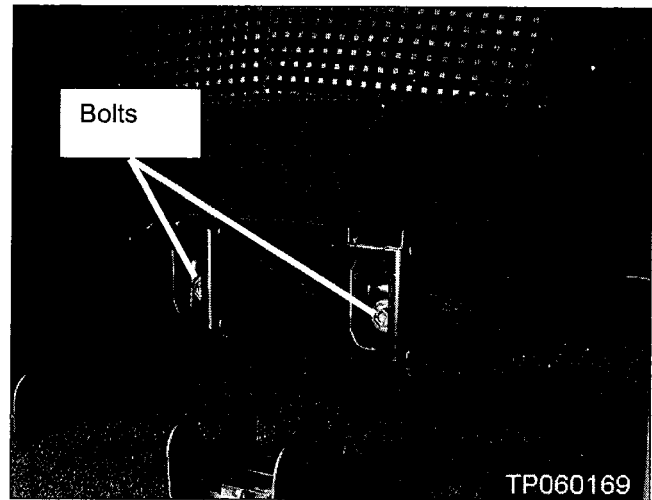

Figure 4

6. Lift the left rear seat cushion.

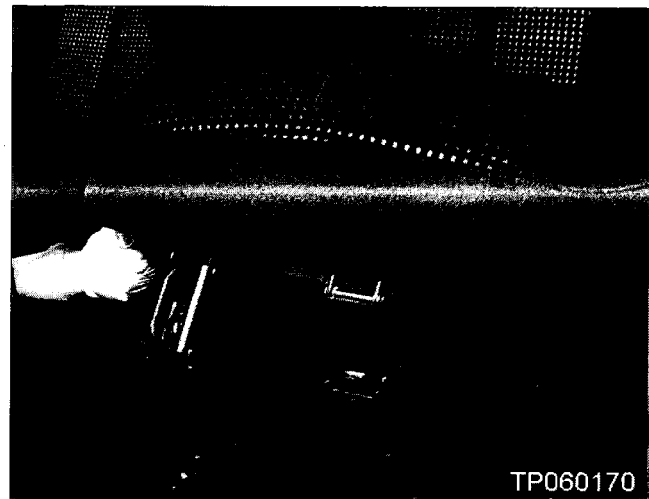

Figure 5

7. Pull the carpet flap off of the fuel pump cover.

8. Twist the 4 clips (one at each corner) to the release position.

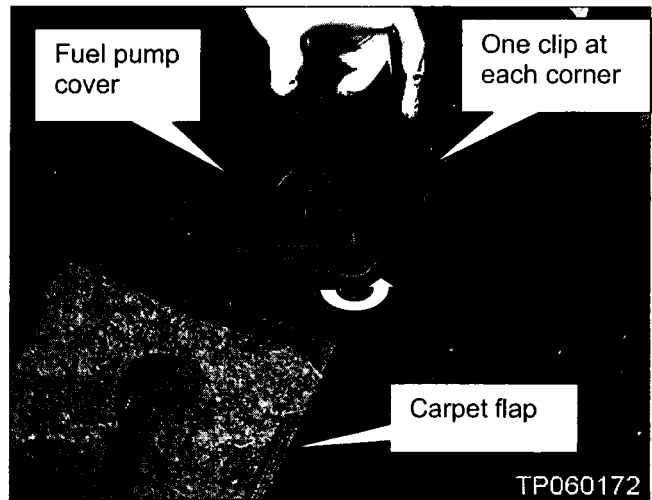

Figure 6

9. Lift the fuel pump cover and disconnect the harness connector.

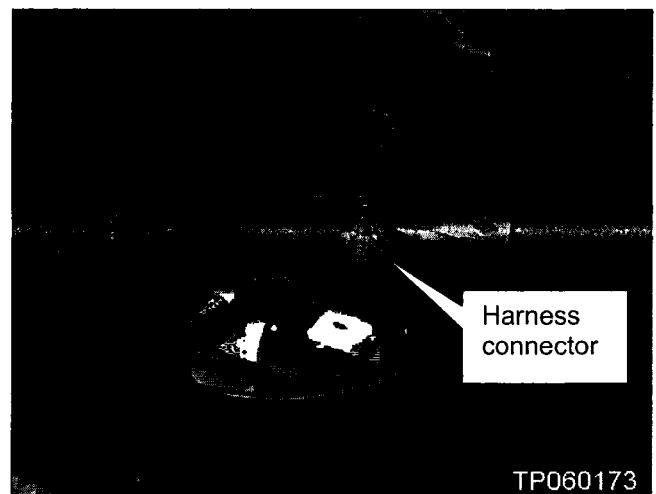

Figure 7



10. Disconnect the fuel feed tube.

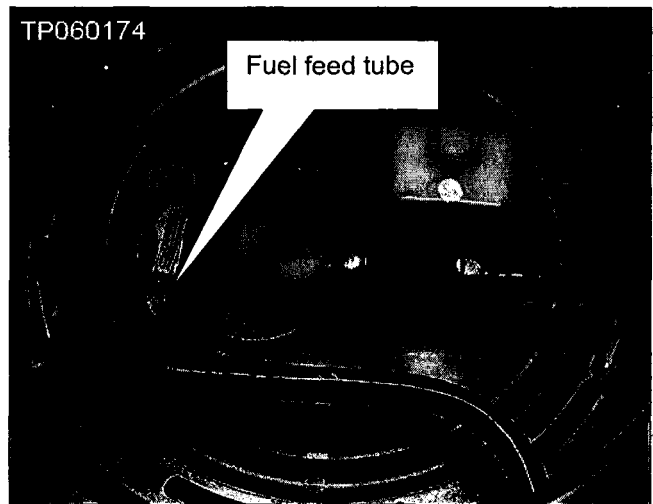

Figure 8

- Push in on the tabs and pull off the fuel feed tube as shown in Figure 9.

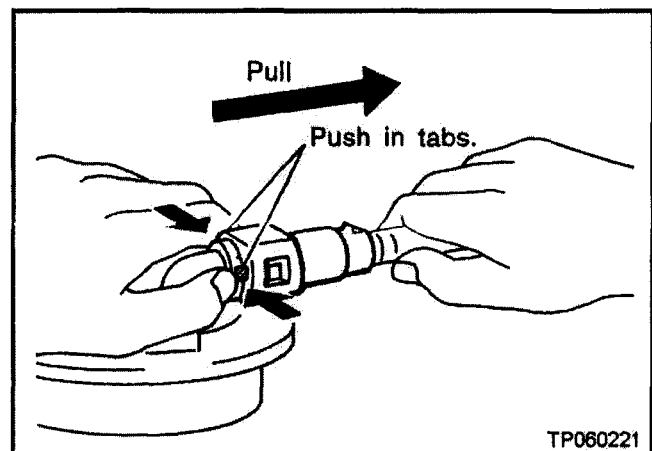

Figure 9

11. Release the parking brake.

12. Raise the vehicle on a hoist.

### Remove Center Exhaust Tube

13. Remove the front center exhaust tube nuts.

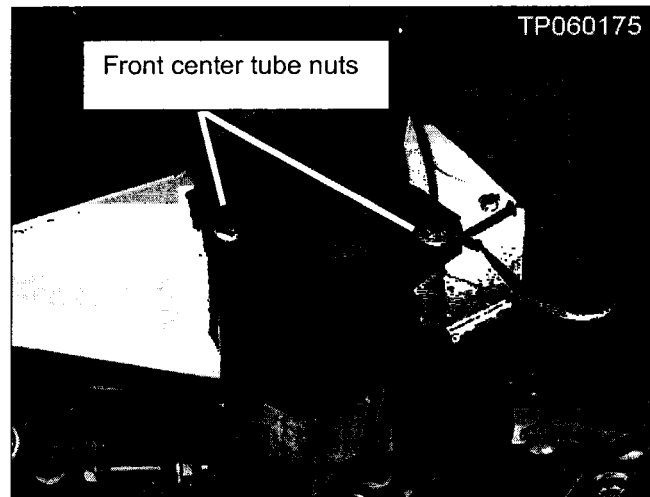

Figure 10

14. Remove the rear center exhaust tube nuts.

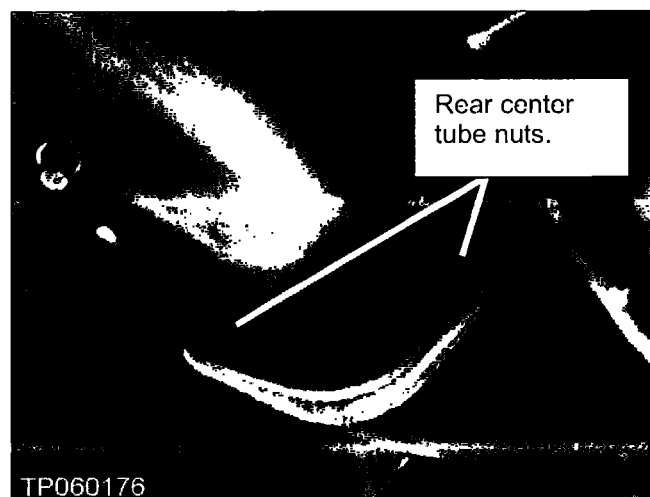

Figure 11

15. Remove the bolts for the center exhaust tube hanger.

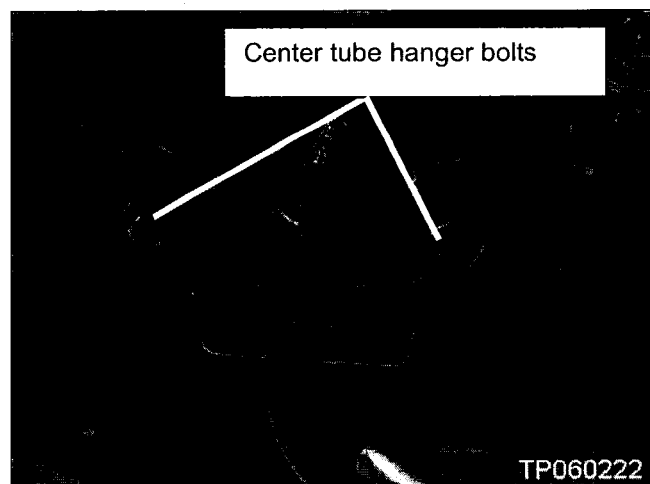

Figure 12

16. Remove the center tube from the vehicle.



Figure 13

**For 2WD models, go to page 30;** the rear suspension does not need to be removed.

**AWD models Only:** Proceed with step 1 below.

**Remove the Rear Suspension Assembly and Replace the Fuel Tank:**

1. Remove both rear wheels/tires.

2. Remove the heat shield bolts shown in Figure 14 and remove the heat shield.

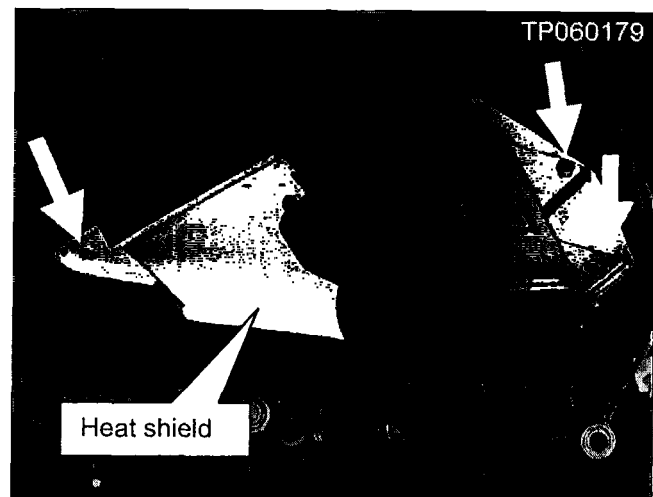

Figure 14

3. Remove both rear brake calipers and hang them from the brake line supports.

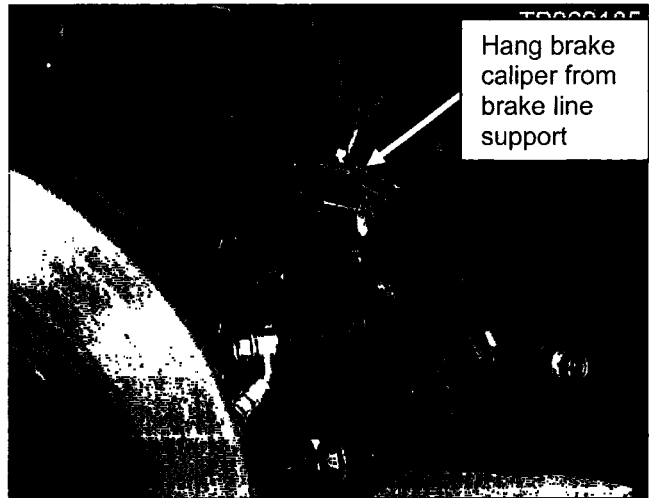

Figure 15

4. Apply an "index" (line-up) mark across the propeller shaft and differential pinion flange.
5. Remove the propeller shaft/differential pinion flange nuts and bolts.

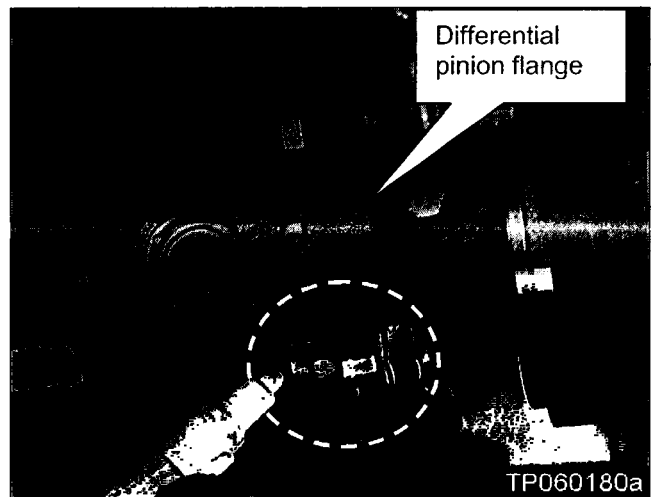

Figure 16

6. Apply an "index" (line-up) mark across the propeller shaft and transmission output flange.
7. Remove the propeller shaft / transmission flange nuts and bolts.

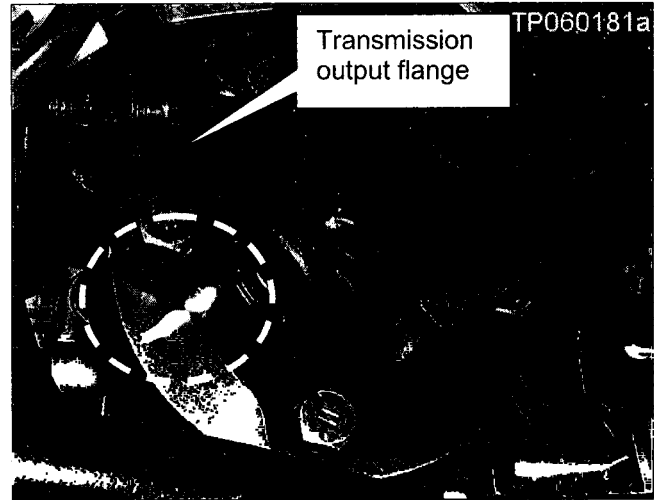

Figure 17

8. Remove the propeller shaft center support nuts and the body brace nuts shown in Figure 18.

**NOTE:** Use new center support nuts when reassembled.

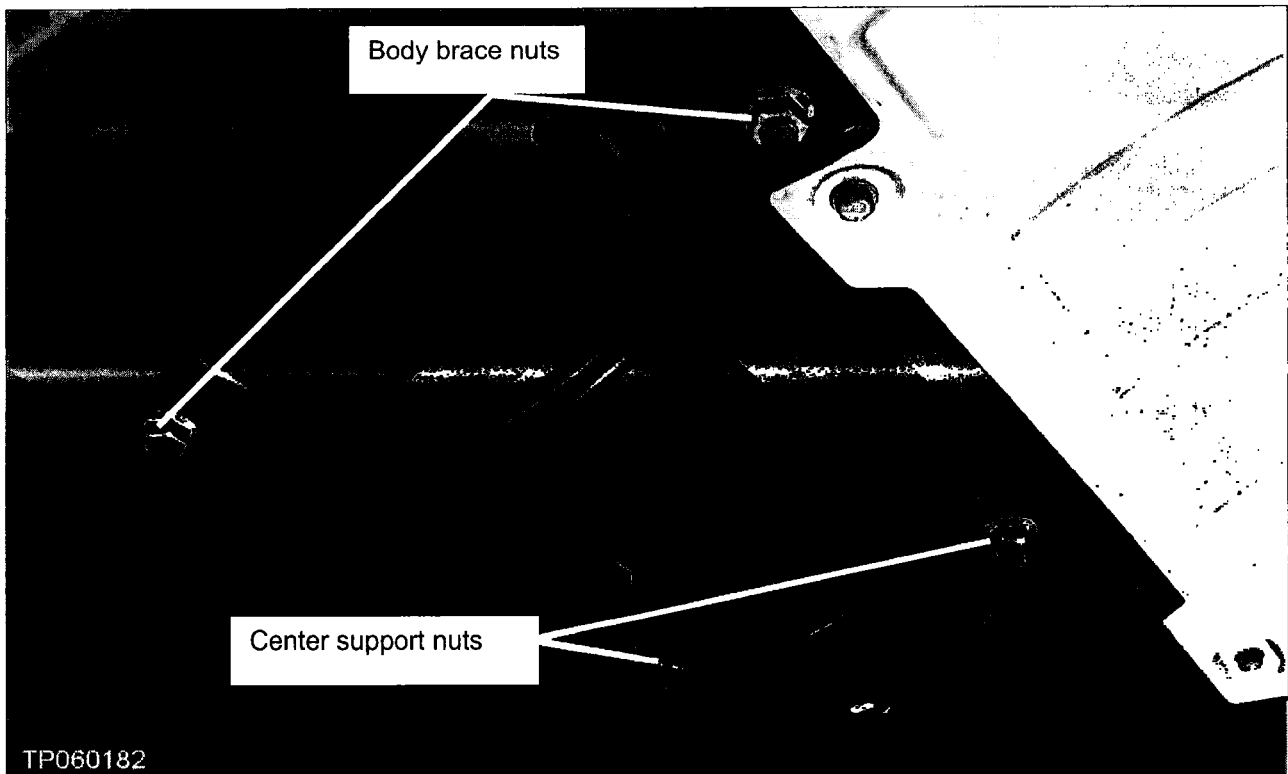

Figure 18

9. Remove the propeller shaft from the vehicle.

10. Remove the parking brake cable nuts shown in Figure 19.

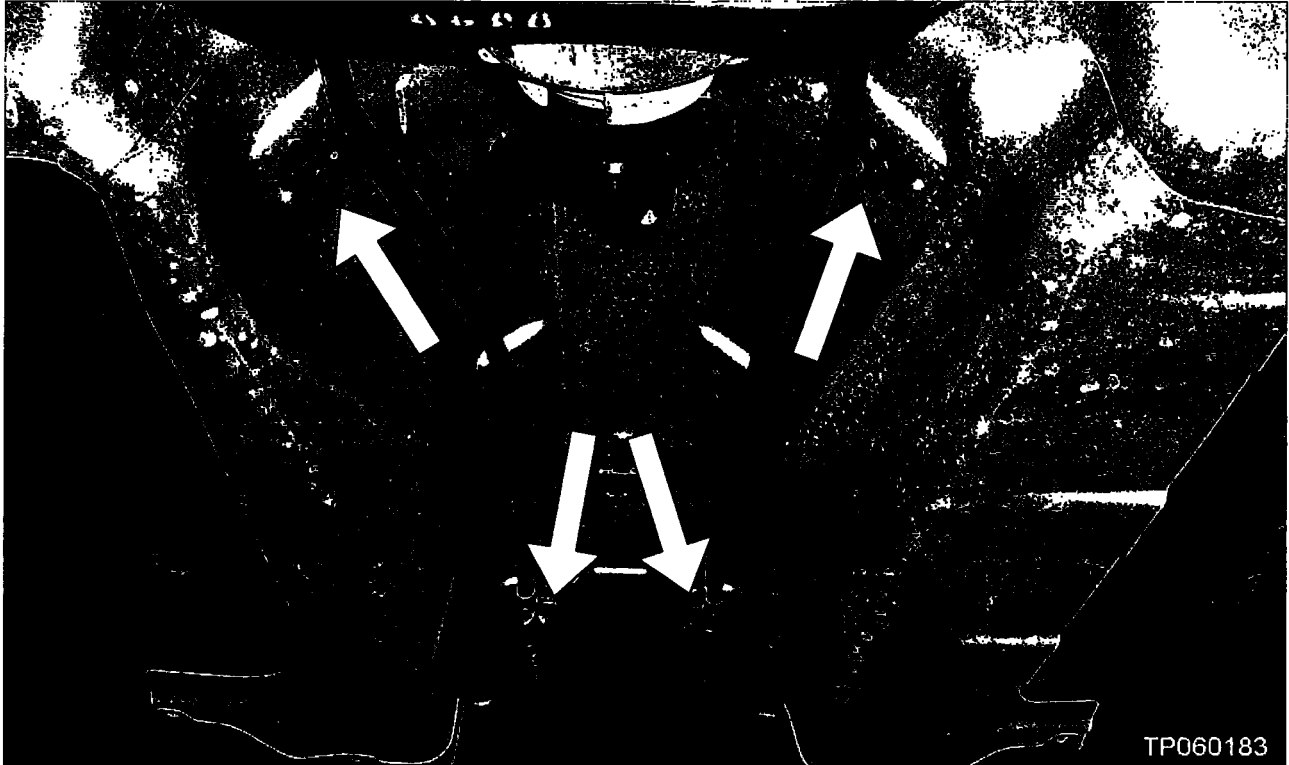

Figure 19

11. Remove (unsnap) the parking brake cables from the metal support brackets.

12. Disconnect the cables from the front equalizer.

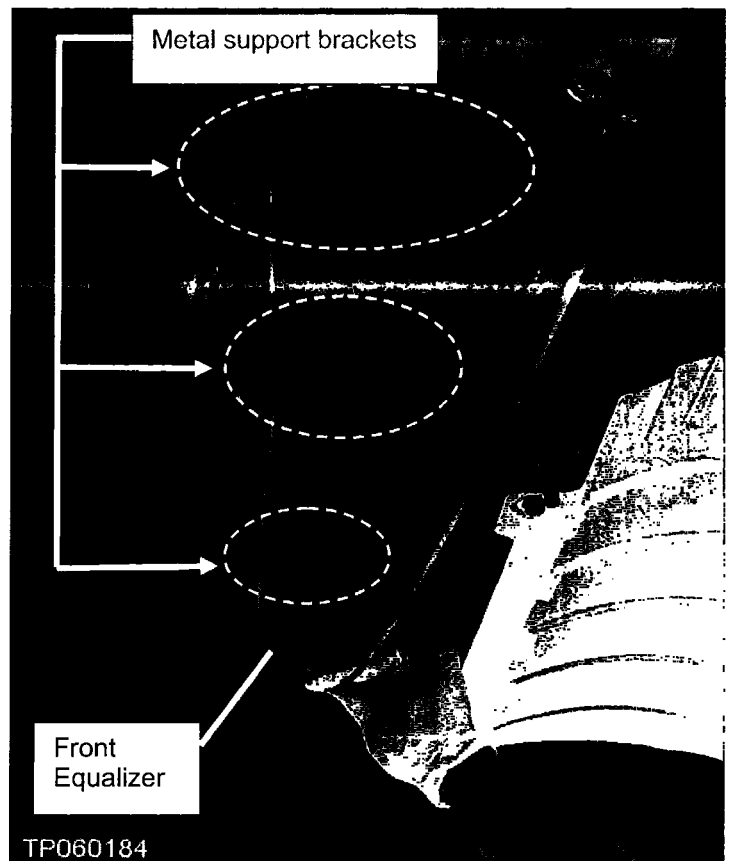

Figure 20

13. Locate the harness connector shown in Figure 21 and disconnect it.

14. Remove the tie wrap shown in Figure 21 from the suspension member using a pair of needle-nose pliers.

NOTE: If you accidentally break the tie wrap, install a new one at re-assembly. The tie wrap part number is 24225-89960.

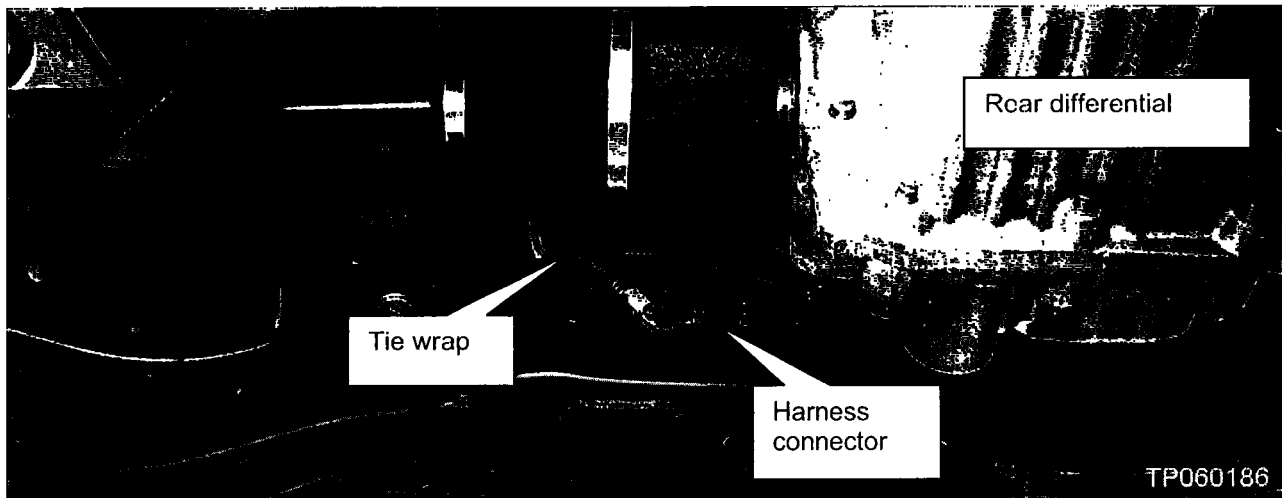

Figure 21

15. One at a time; remove the lower mounting bolts for both rear shocks.

- Support the lower link with a jack while removing the bolt.

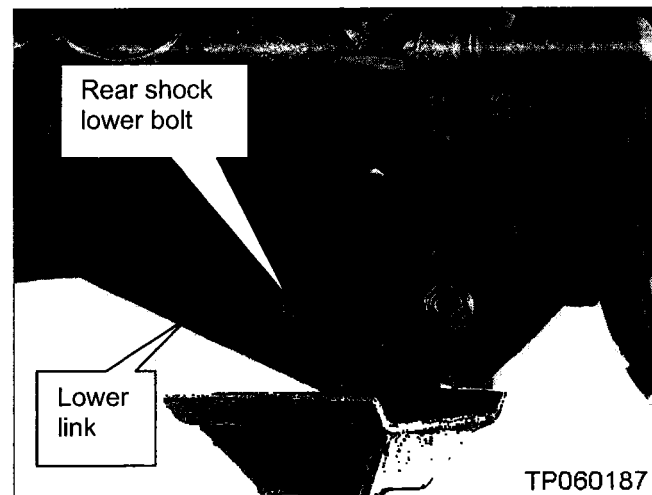

Figure 22

16. Place an "index" (line-up) mark across the rear coil springs and upper spring seats.

- Do this for the left and right rear coil spring.

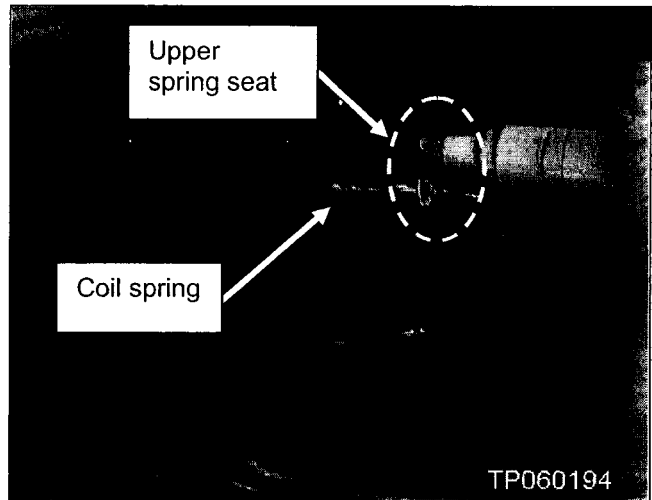

Figure 23

17. Place a support jack (jack stand) under the front of the vehicle to help stabilize the vehicle on the lift (see Figure 24).

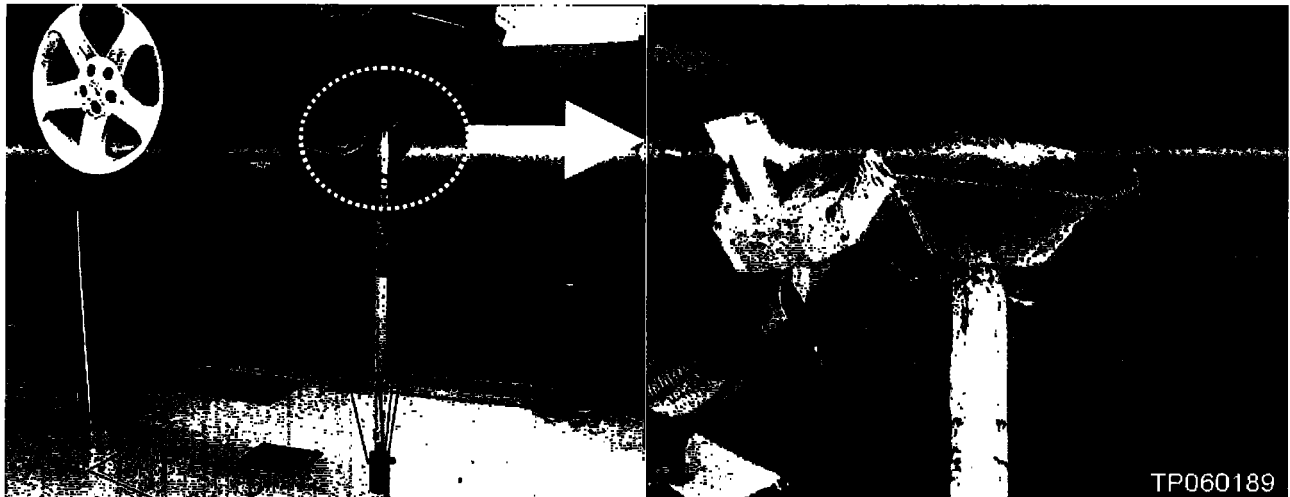

Figure 24



18. Position a transmission jack under the rear suspension member/rear differential.

- Make sure the suspension member/differential is centered on the transmission jack.
- Use a tie-down strap to secure the suspension member to the jack.

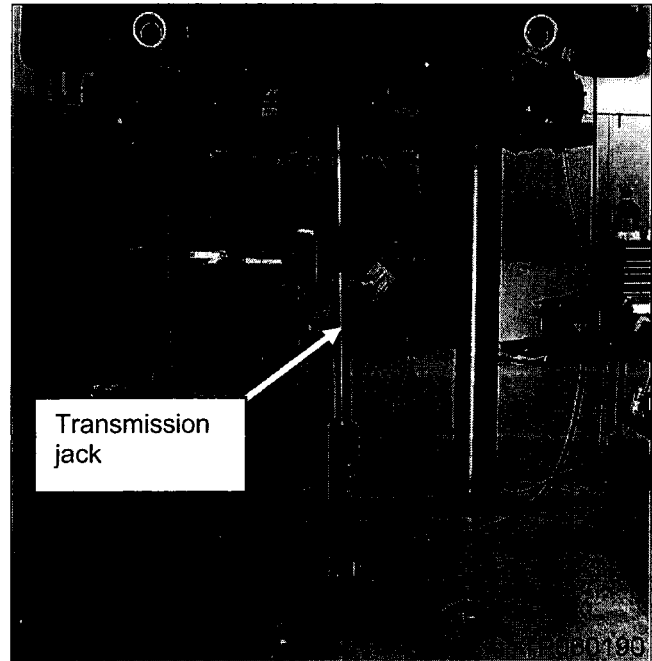

Figure 25

19. Remove the bolts and nut shown in Figure 26.

- Do this for both the left and right side.

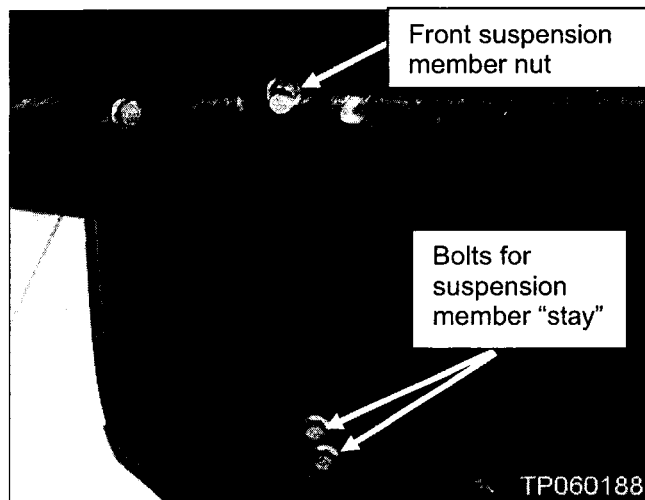

Figure 26

20. Remove both the left and right side rear suspension member nuts.

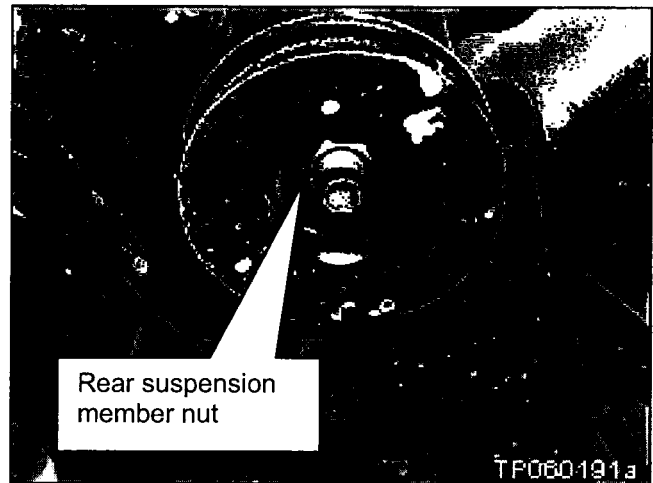

Figure 27

**IMPORTANT:**

- Make sure the suspension member/differential is centered and balanced on the transmission jack.
- Make sure the suspension member is secured to the jack with a tie-down strap.

21. Carefully lower the rear suspension member and remove it from the vehicle.

- Place the suspension member out of the way.

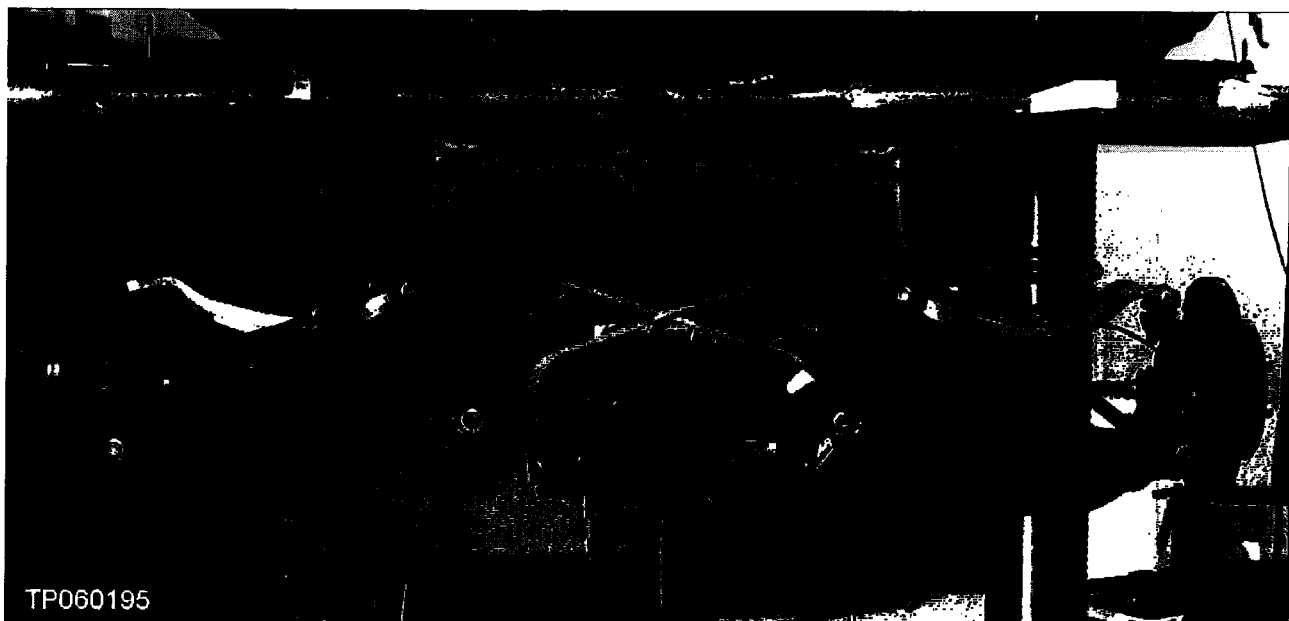

Figure 28

22. Remove the nuts shown in Figure 29.

- These nuts secure the front of the fuel tank protector.

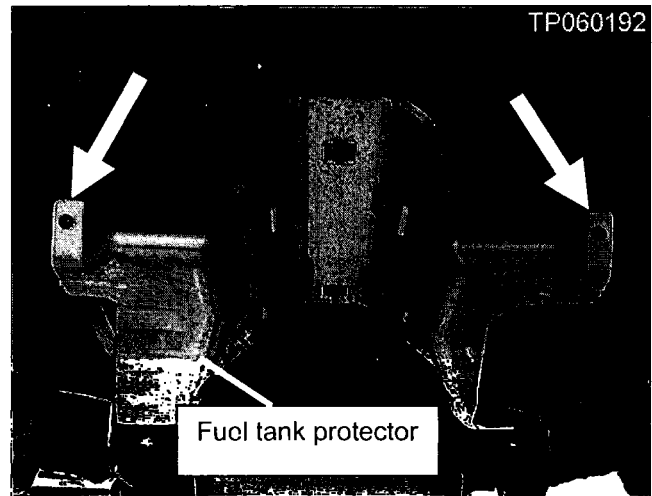

Figure 29

23. Remove the nuts shown in Figure 30.

- These nuts secure the rear of the fuel tank protector.

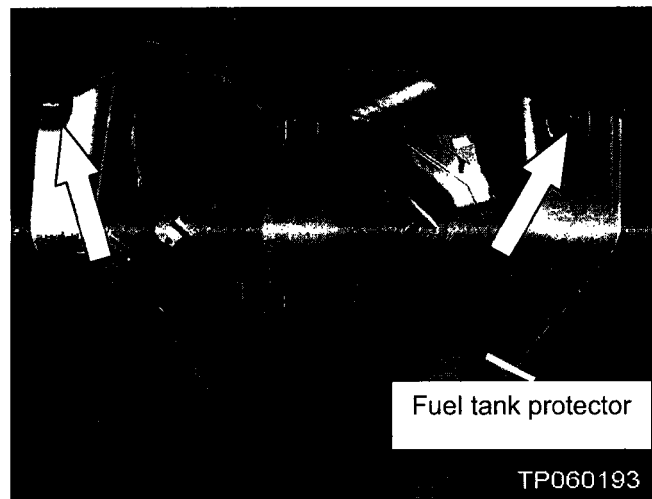

Figure 30

24. Use a small flat blade screwdriver (pocket screwdriver) to release the 2 clips show in Figure 31, then remove the fuel tank protector.

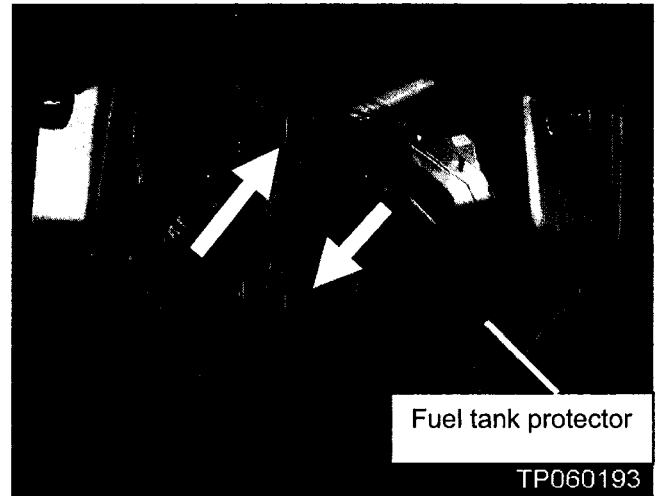

Figure 31

**IMPORTANT:** The fuel tank must be **less than ¼ full.**

25. Disconnect the three fuel lines / hoses shown in Figure 32 from the fuel tank.

- Disconnect them at the points shown in Figure 32.

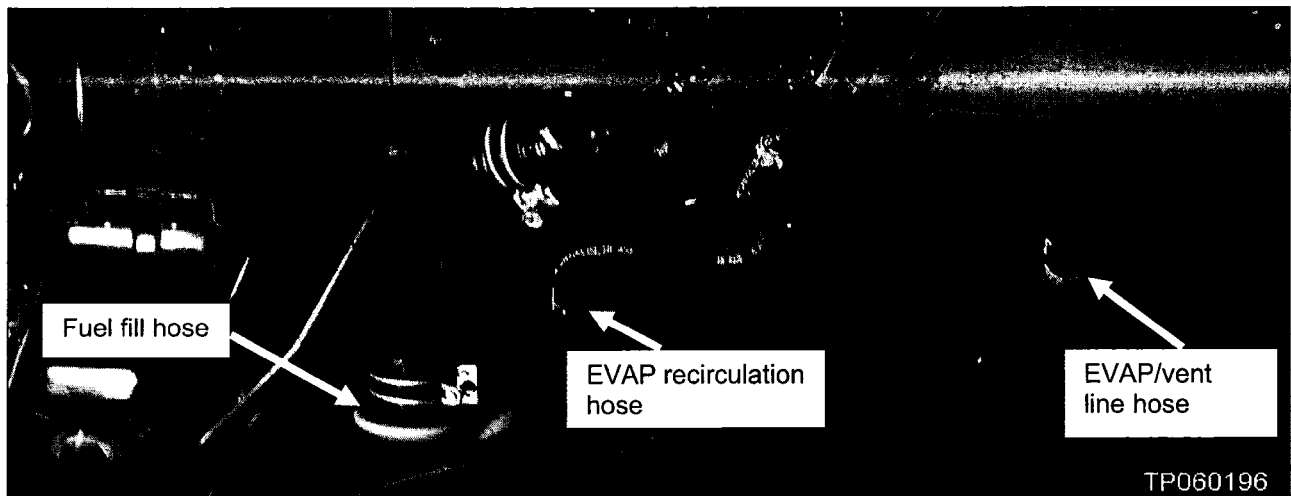

Figure 32

26. Use 2 transmission jacks to support both sides of the fuel tank.

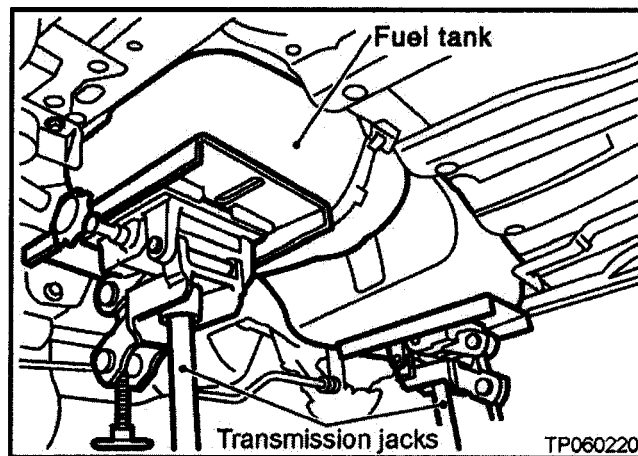

Figure 33

27. Remove the fuel tank strap bolts shown in Figure 34.

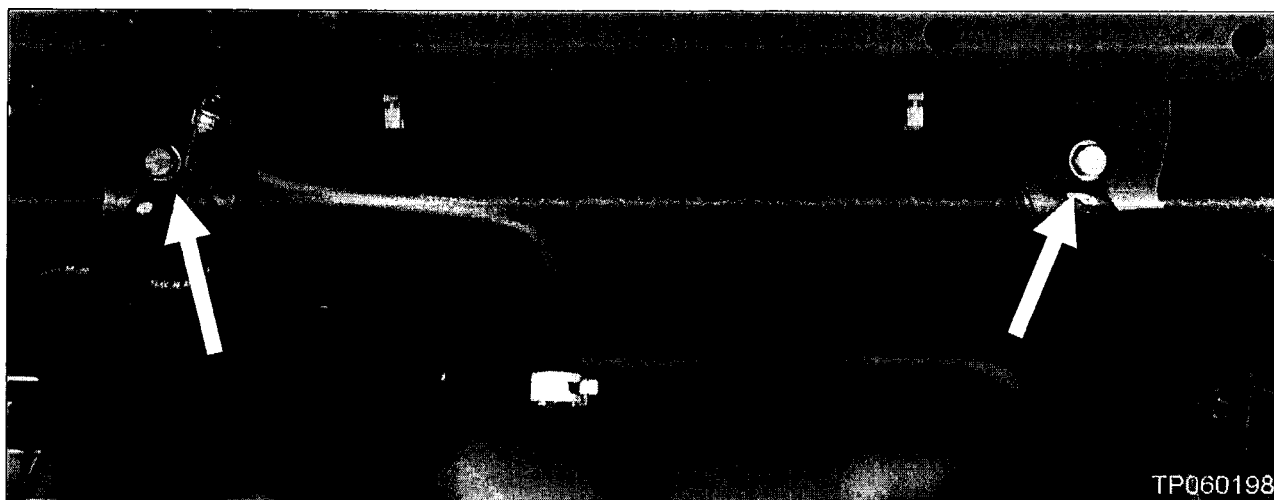

Figure 34

28. Carefully lower the fuel tank out of the vehicle.

**CAUTION:** Both jacks should be lowered evenly at the same time to keep the fuel tank from slipping.

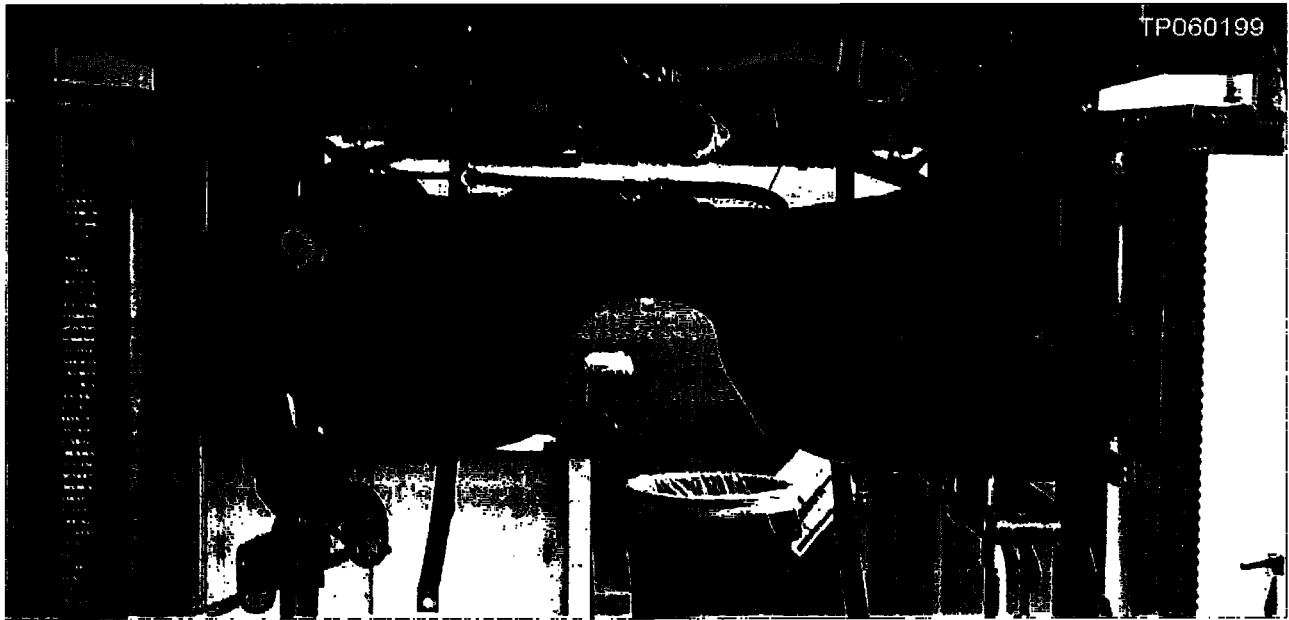

Figure 35

29. Lift the fuel tank from the transmission jacks and set it in a clean working area.

### Remove Parts From the Old Fuel Tank

30. Disconnect the EVAP line from the top of the fuel pump.

- a. Push the locking tab down.
- b. Pull the hose off.

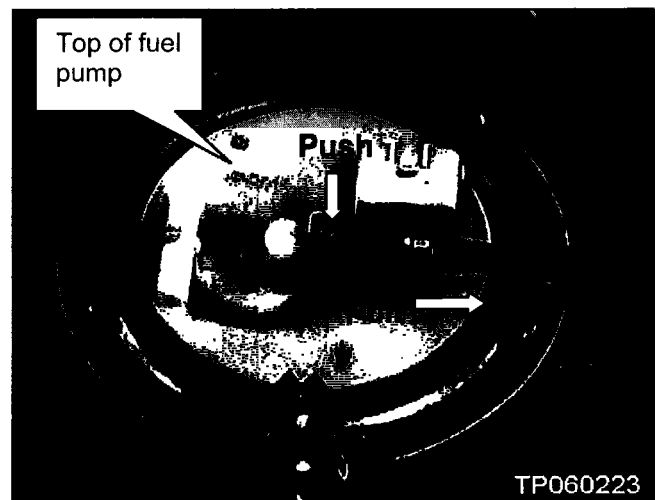

Figure 36

31. Remove the lock ring from the top of the fuel pump.



Figure 37

32. Lift the fuel pump out of the tank.

33. Disconnect the electrical connector shown in Figure 38.

34. Disconnect the fuel line.

- a. Push the locking tab down.
- b. Pull the hose off.

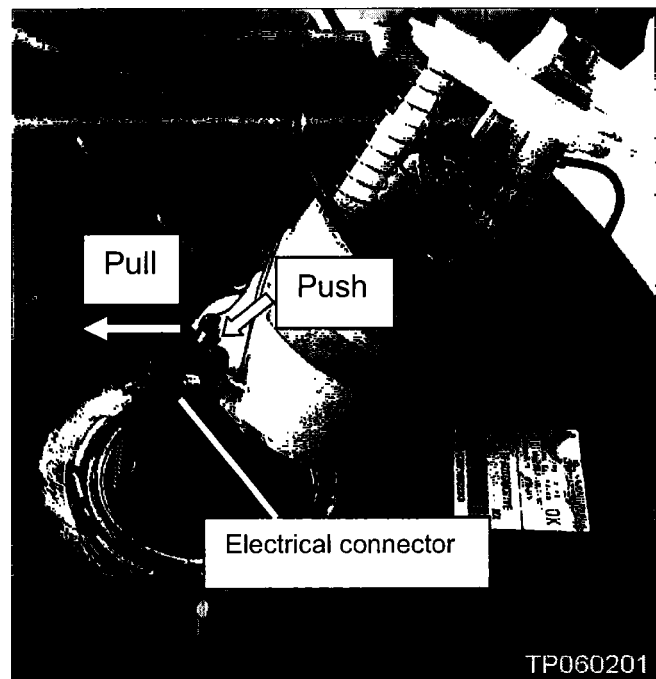

Figure 38

TP060201

35. Remove the lock ring from the top of the sub fuel level sensor.

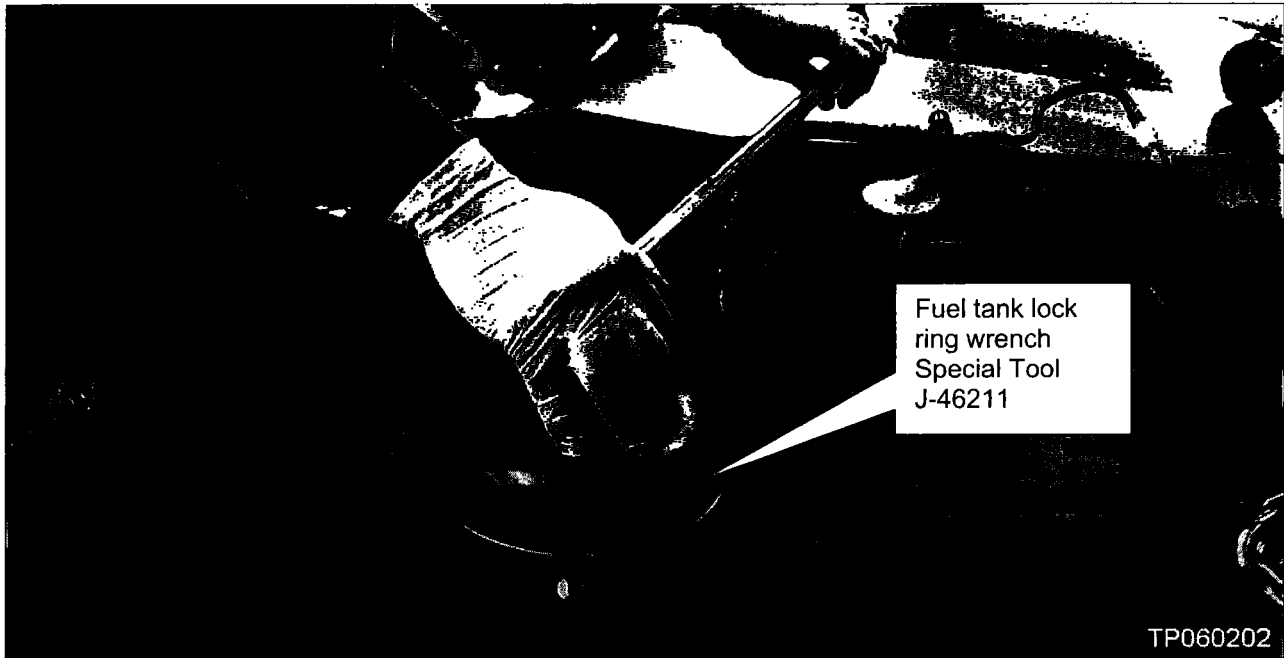

Figure 39

36. Lift the sub fuel level sensor half way out of the tank.

37. Then reach in the tank and pull out the fuel line. Then pull the level sensor completely out of the tank.

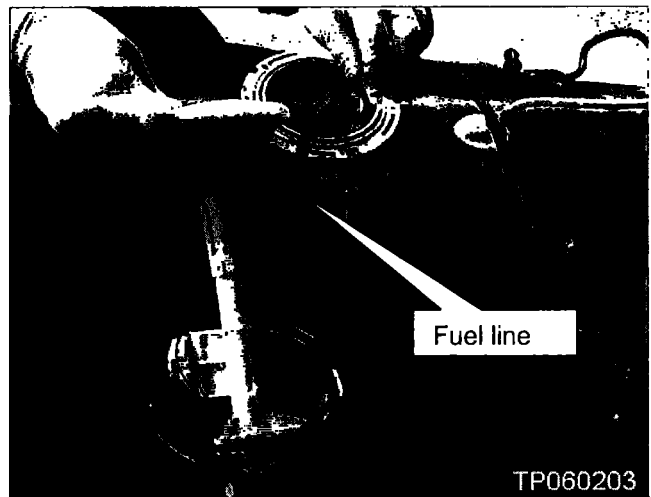

Figure 40



## Install Parts Into the New Fuel Tank.

38. Install the new seal on the sub fuel level sensor opening of the new fuel tank.



Figure 41

39. Install the sub fuel level sensor half way, then feed the fuel line across to the other side of the new tank (see Figure 42).

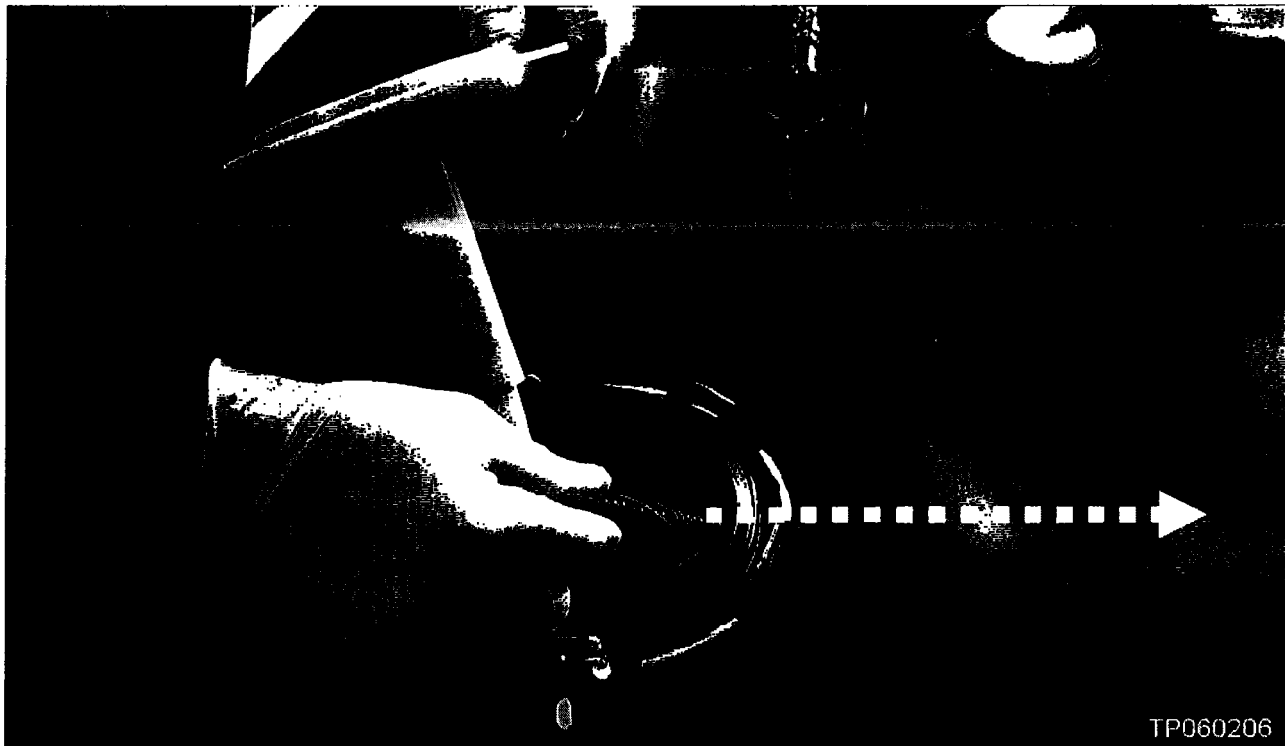

Figure 42

40. Fully install the sub fuel level sensor into the tank.

41. Make sure the arrow on the tank and the arrow on the top of the sensor are aligned as shown in Figure 43.

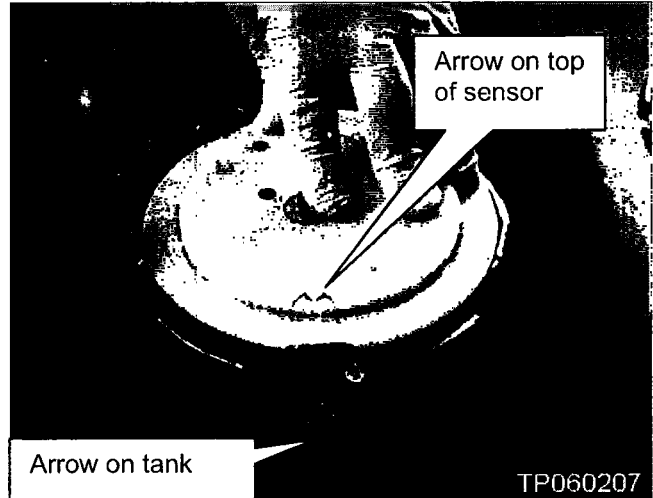

Figure 43

42. Install the lock ring on top of the sub fuel level sensor.

- Use fuel tank lock ring wrench, Special Tool J-46211.
- For additional information on the use of this special tool, see NTB02-126.

43. Install the new seal on the fuel pump opening of the new fuel tank.

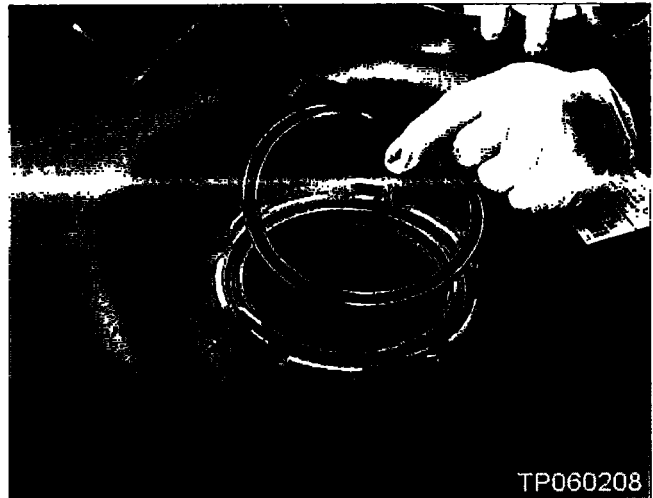

Figure 44

44. Pull the fuel line out of the tank.

45. Connect the electrical connector shown in Figure 45.

46. Push the fuel line on until it snaps in place.

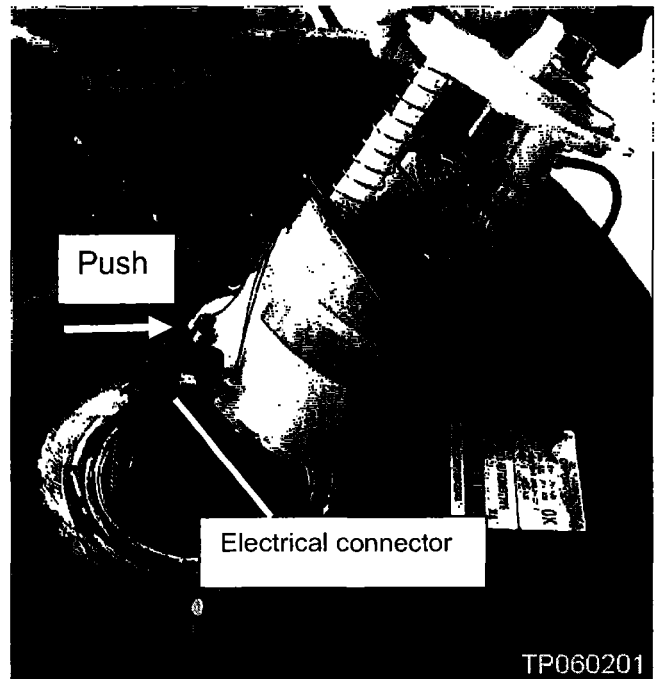

Figure 45

47. Install the fuel pump into the tank.

48. Make sure the arrow on the tank and the arrow on the top of the fuel pump are aligned as shown in Figure 46.

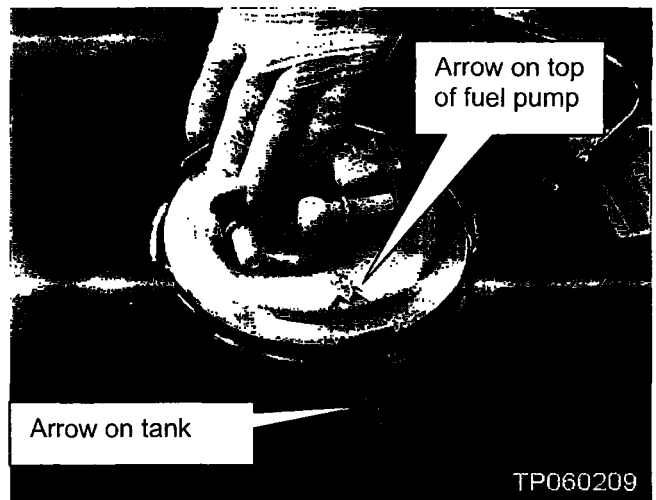

Figure 46

49. Install the lock ring on top of the fuel pump.

- Use fuel tank lock ring wrench, Special Tool J-46211.
- For additional information on the use of this special tool, see NTB02-126.

## Re-Assembly

50. Re-install all components in the reverse order of removal, making sure of the following:

- Tighten the fuel filler hose clamp at the fuel tank so the distance between the bolt head and metal plate is set to the proper dimension (see Figure 47a).

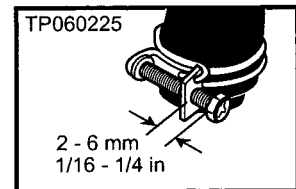

Figure 47a

- Index marks across the rear coil springs and upper spring seats are lined up.

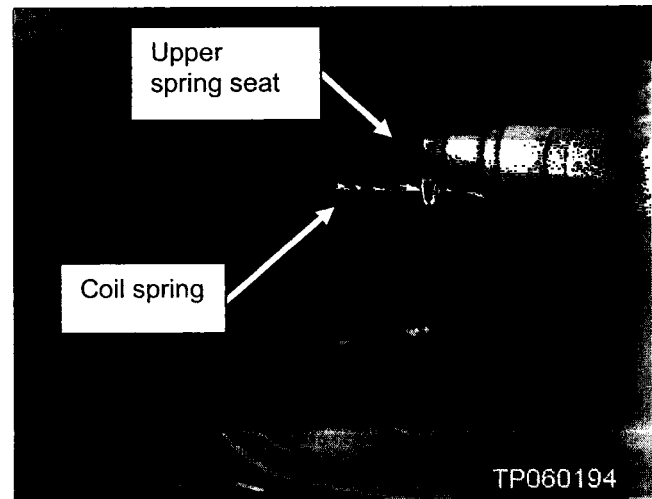

Figure 47b

- Torque rear suspension member nuts to 123 N.m (13 kg-m, **91 ft-lb**).



Figure 47c

- Torque front suspension member nuts to 123 N.m (13 kg-m, **91 ft-lb**)
- Torque suspension member stay bolts to 55 N.m (5.6 kg-m, **41 ft-lb**)

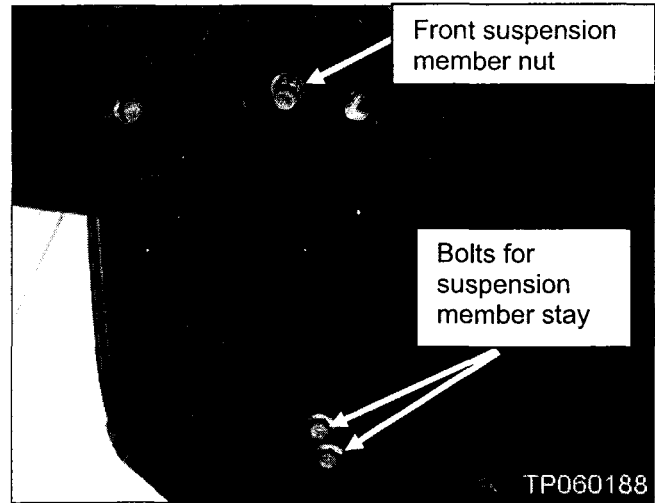

Figure 47d

- Torque lower shock bolts to 110 N.m (11 kg-m, **81 ft-lb**)

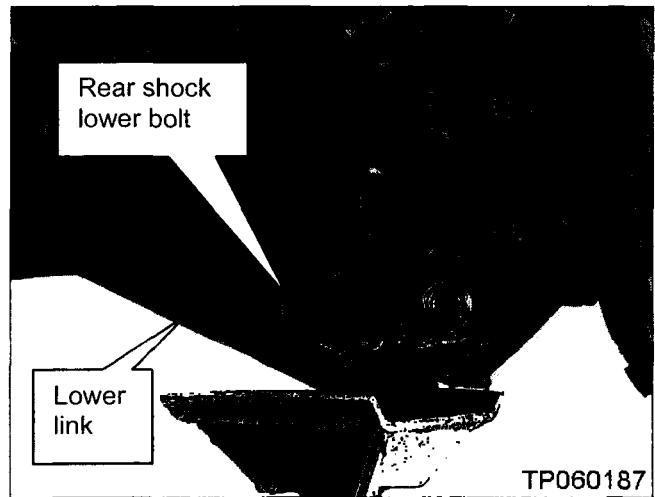

Figure 47e

- Index mark across the propeller shaft and differential pinion flange is lined up.

Use new bolts and nuts.

Torque bolts/nuts to 59.9 N.m (6.1 kg-m, **44 ft-lb**)

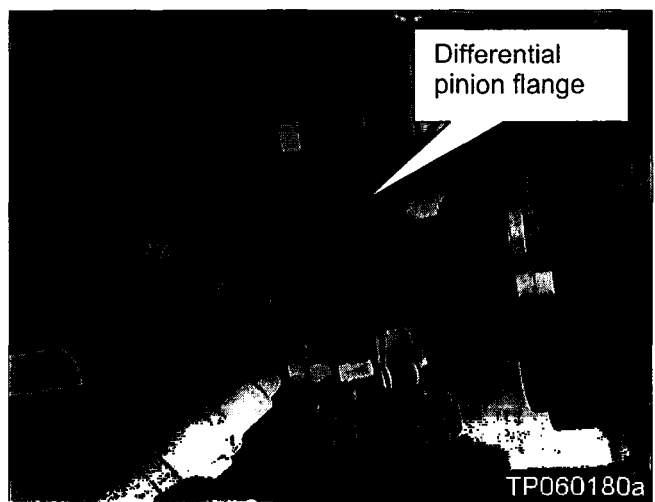

Figure 47f

- Index mark across the propeller shaft and transmission output flange is lined up.

Use new bolts and nuts.

Torque bolts/nuts to  
59.9 N.m (6.1 kg-m, **44 ft-lb**)

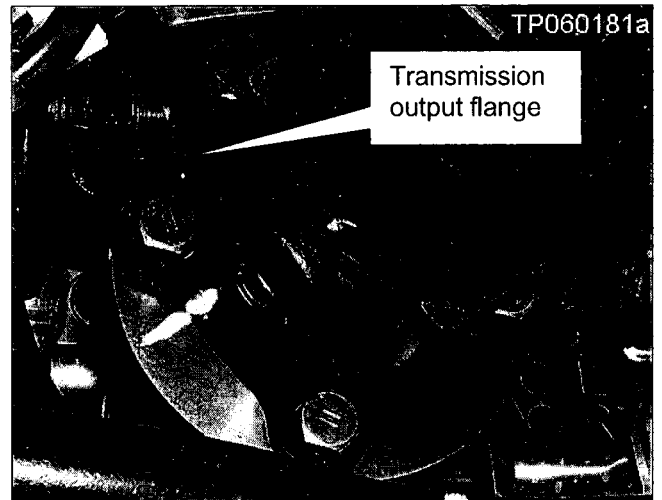

Figure 47g

- Rear brake caliper torque member bolts are tightened to 84.3 N.m (8.6 kg-m, **62 ft-lb**)
- Use new gaskets at the front and rear of the center exhaust tube.

51. Re-connect the negative battery cable.

52. Re-program all radio station pre-sets.

53. Transfer fuel from the old fuel tank to the new tank.

## 2WD Models Only: Replace the Fuel Tank

For AWD models, go back to page 10.

1. Remove the parking brake cable nuts shown in Figure 48.

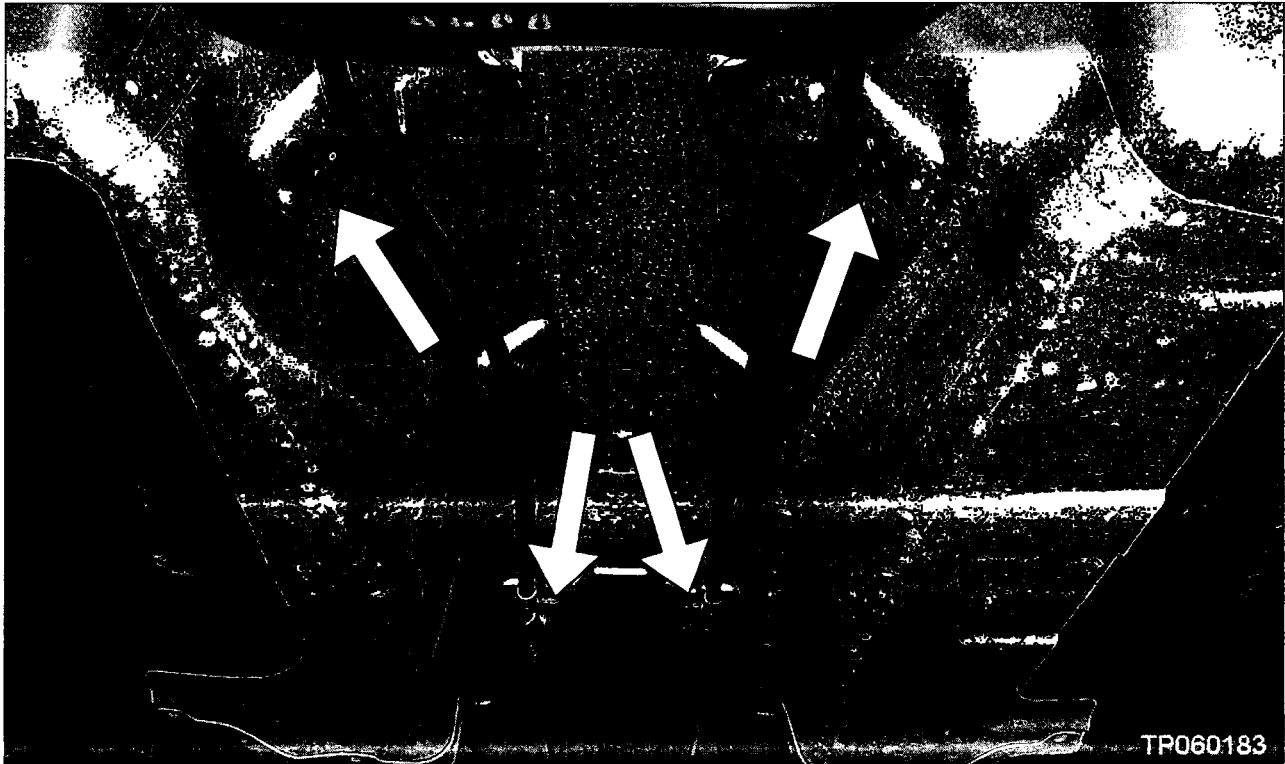

Figure 48

2. Remove (unsnap) the parking brake cables from the metal support brackets.

3. Disconnect the cables from the front equalizer.

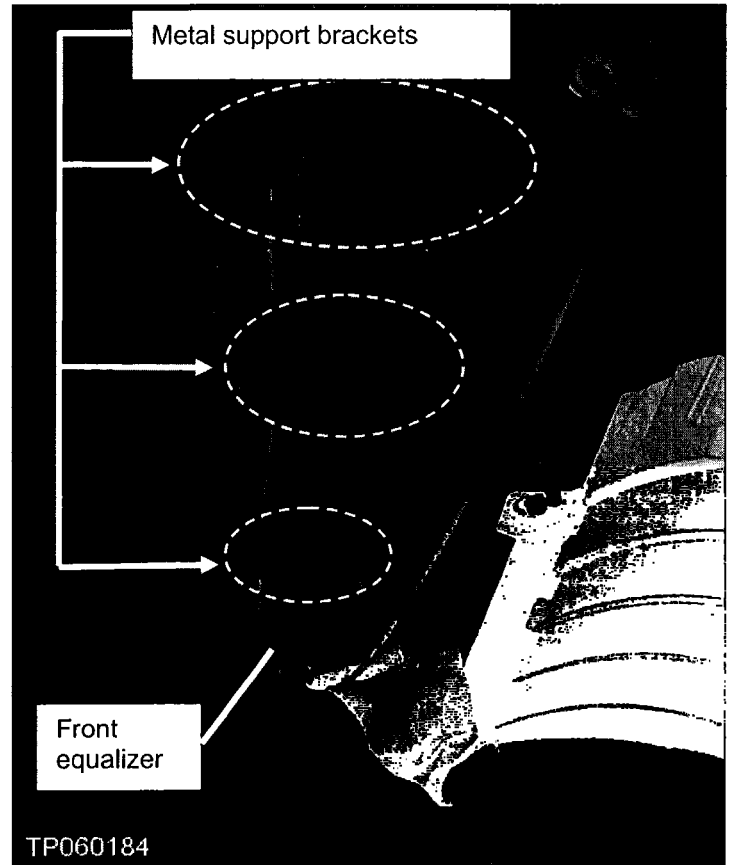

Figure 49

4. Remove the nuts shown in Figure 50.

- These nuts secure the front of the fuel tank protector.

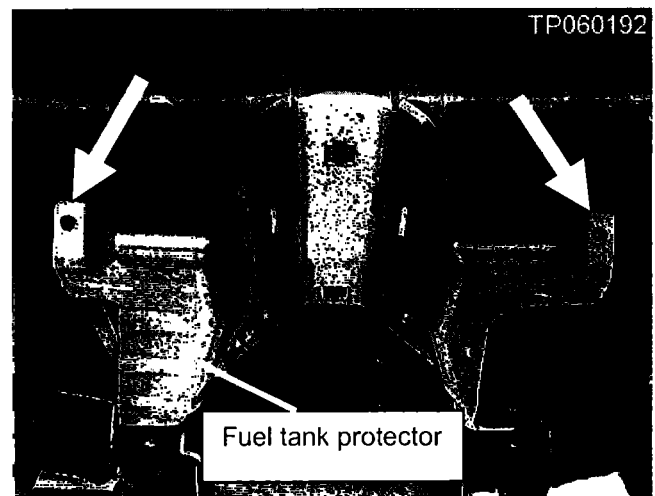

Figure 50



5. Remove the nuts shown in Figure 51.

- These nuts secure the rear of the fuel tank protector.

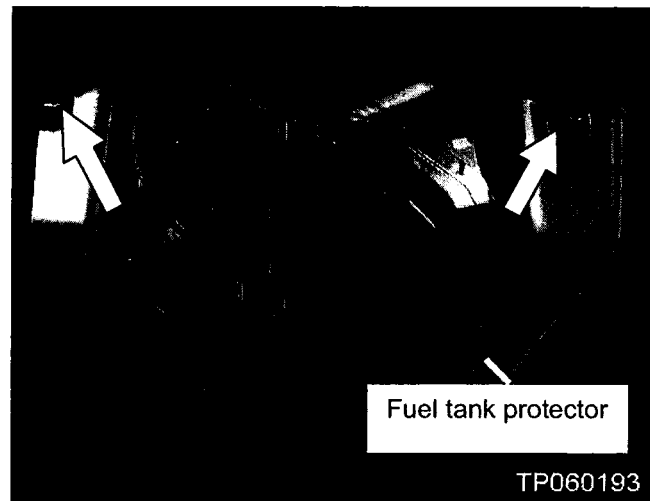

Figure 51

6. Use a small flat blade screwdriver (pocket screwdriver) to release the 2 clips show in Figure 52, then remove the fuel tank protector.

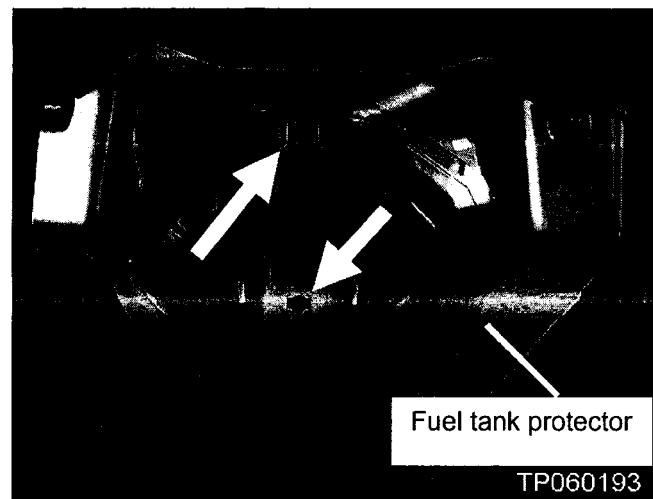

Figure 52

**IMPORTANT:** The fuel tank must be **less than ¼ full**.

7. Disconnect the EVAP recirculation hose from the metal line.

- Disconnect at the point shown in Figure 53.

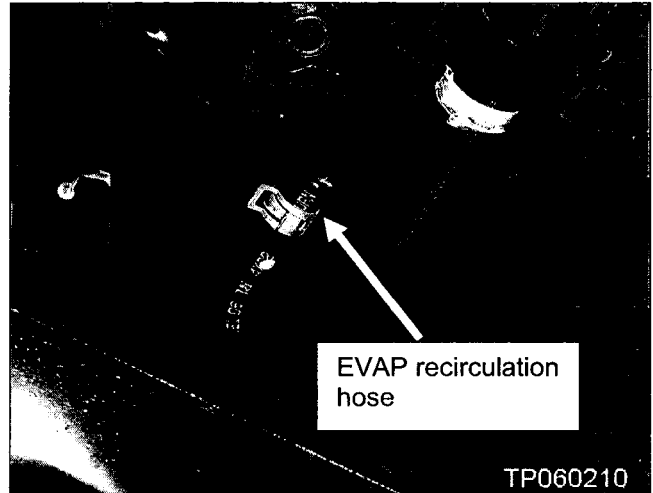

Figure 53

8. Disconnect the fuel fill hose from the metal tube.

- Disconnect at the point shown in Figure 54.

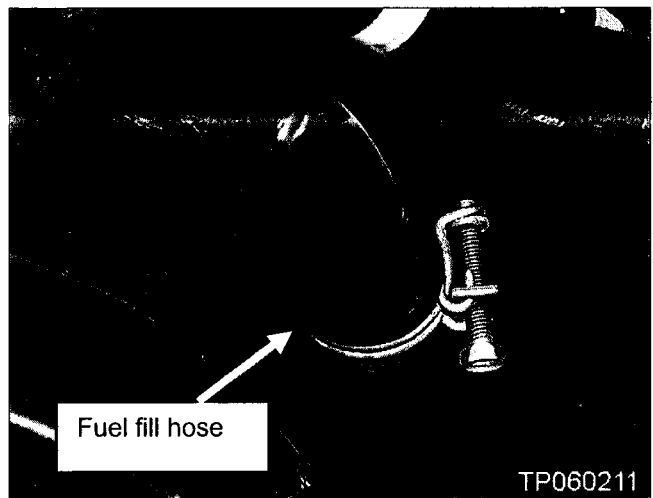

Figure 54

9. Use 2 transmission jacks to support both sides of the fuel tank.

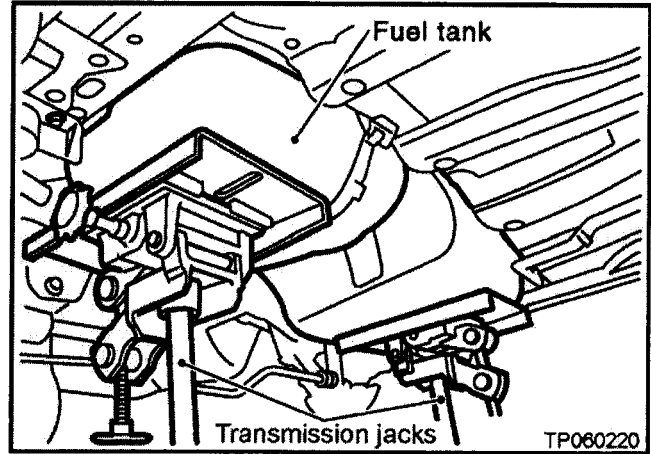

Figure 55

10. Remove the fuel tank strap bolts shown in Figure 56.



Figure 56

11. Carefully lower the fuel tank just enough to disconnect the EVAP/vent line hose shown in Figure 57.

- Disconnect the hose from the fuel tank at the point shown in Figure 57.

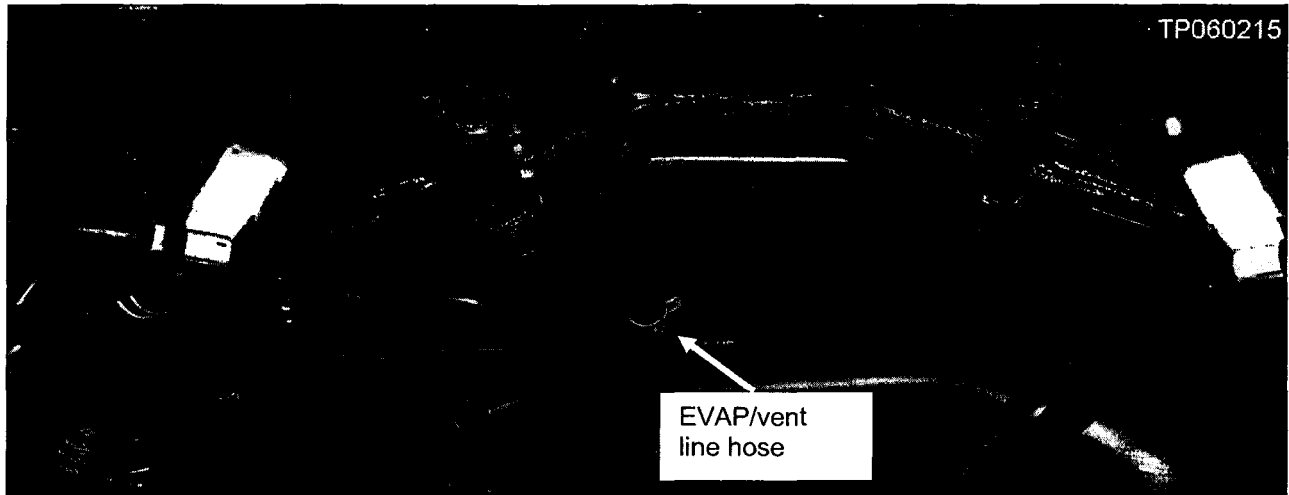

Figure 57

12. Carefully lower the fuel tank completely out to the vehicle.

**CAUTION:** Both jacks should be lowered evenly at the same time to keep the fuel tank from slipping.



Figure 58

13. Lift the fuel tank from the transmission jacks and set it in a clean working area.

### Remove Parts From the Old Fuel Tank

14. Disconnect the EVAP line from the top of the fuel pump.

- a. Push the locking tab down.
- b. Pull the hose off.

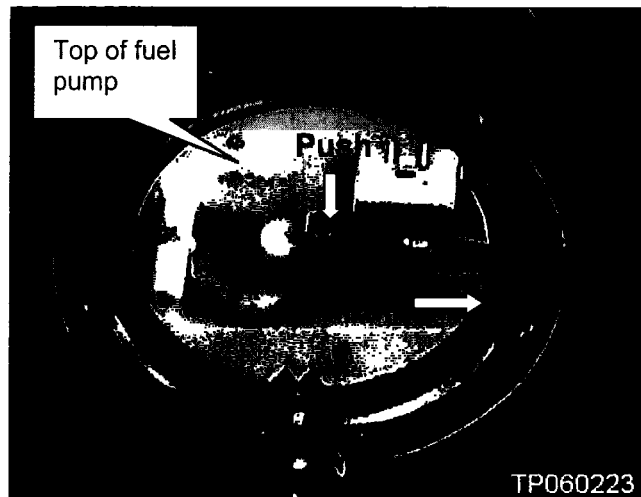

Figure 59

15. Remove the lock ring from the top of the fuel pump.

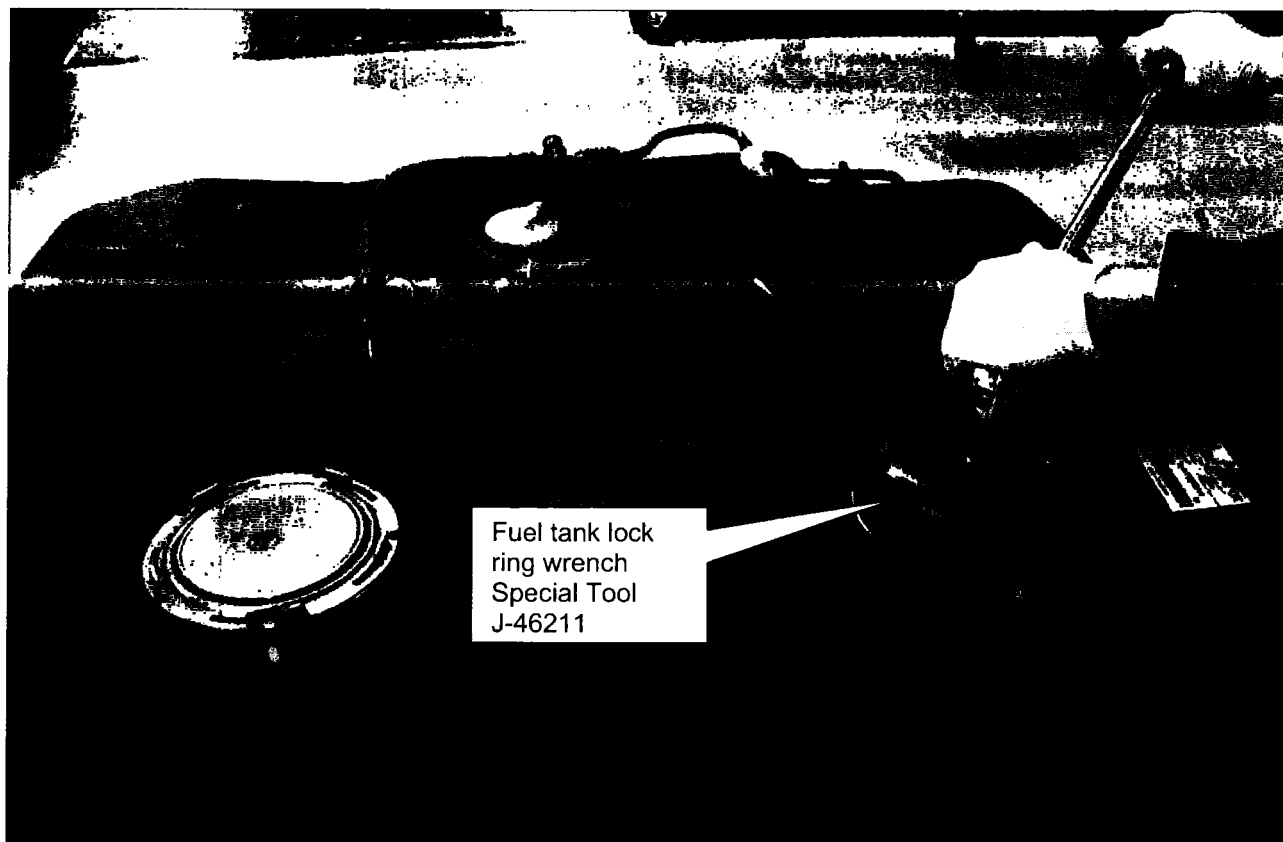

Figure 60

16. Lift the fuel pump out of the tank.

17. Disconnect the electrical connector shown in Figure 61.

18. Disconnect the fuel line.

- a. Push the locking tab down.
- b. Pull the hose off.

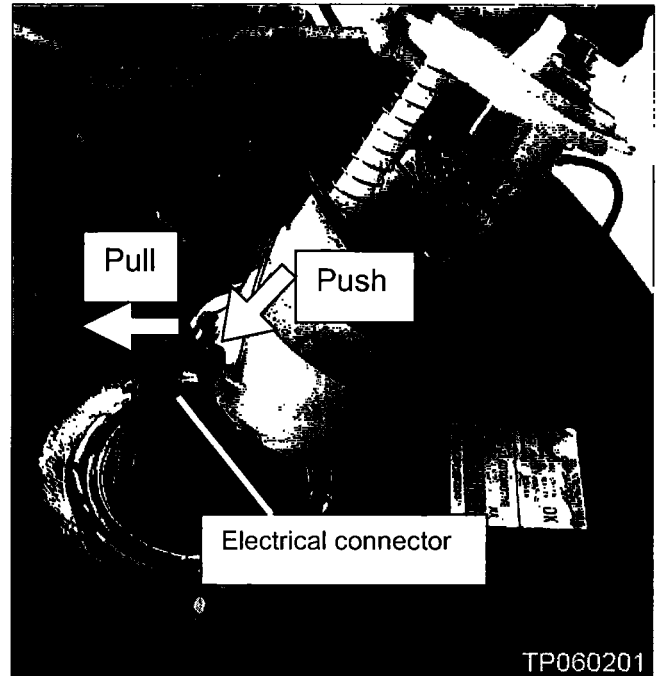

Figure 61

19. Remove the lock ring from the top of the sub fuel level sensor.

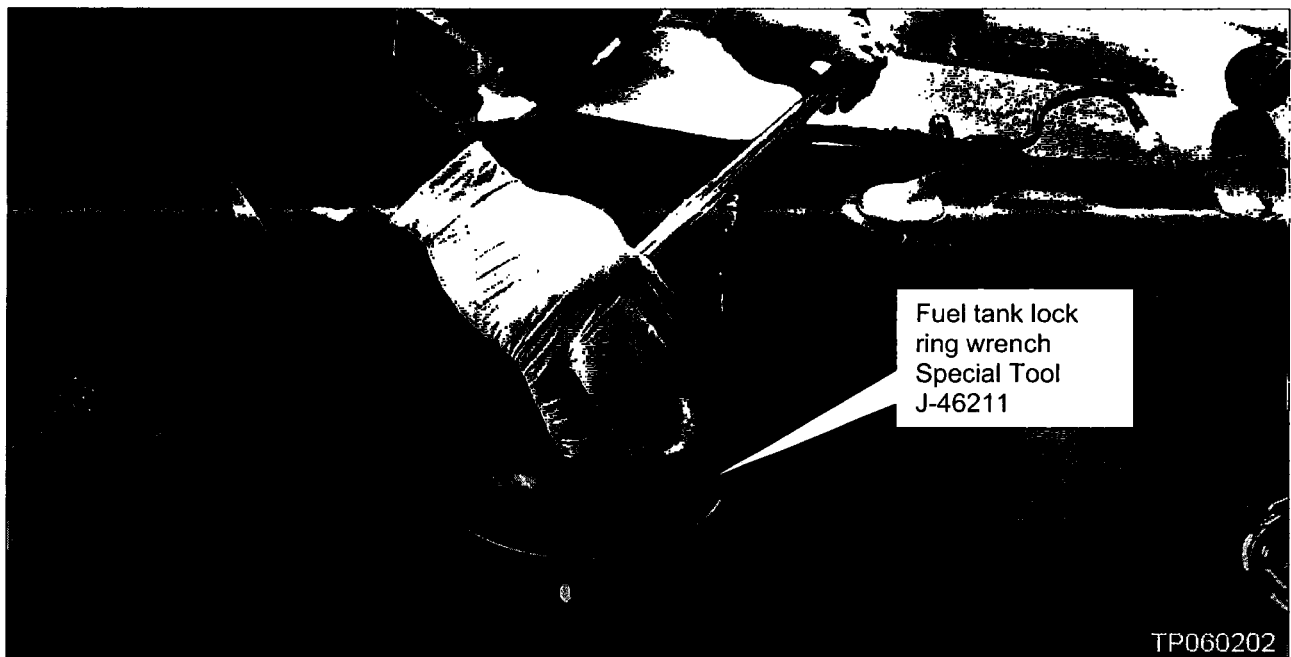

Figure 62

20. Lift the sub fuel level sensor half way out of the tank.

21. Then reach in the tank and pull out the fuel line. Then pull the level sensor completely out of the tank.

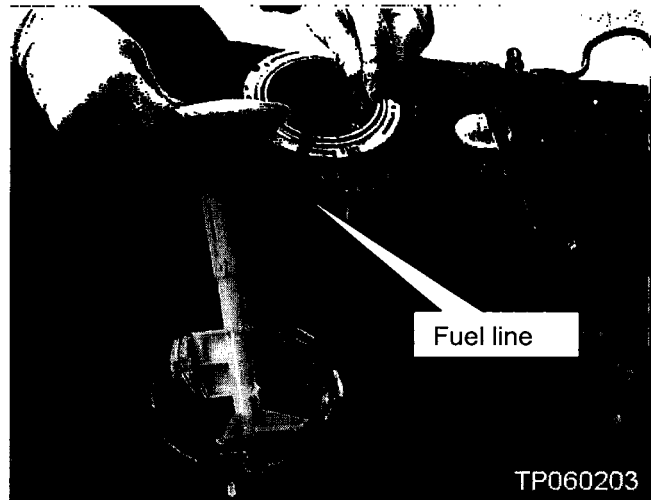

Figure 63

### Install Parts Into the New Fuel Tank

22. Install the new seal on the sub fuel level sensor opening of the new fuel tank.



Figure 64

23. Install the sub fuel level sensor half way, then feed the fuel line across to the other side of the new tank (see Figure 65).

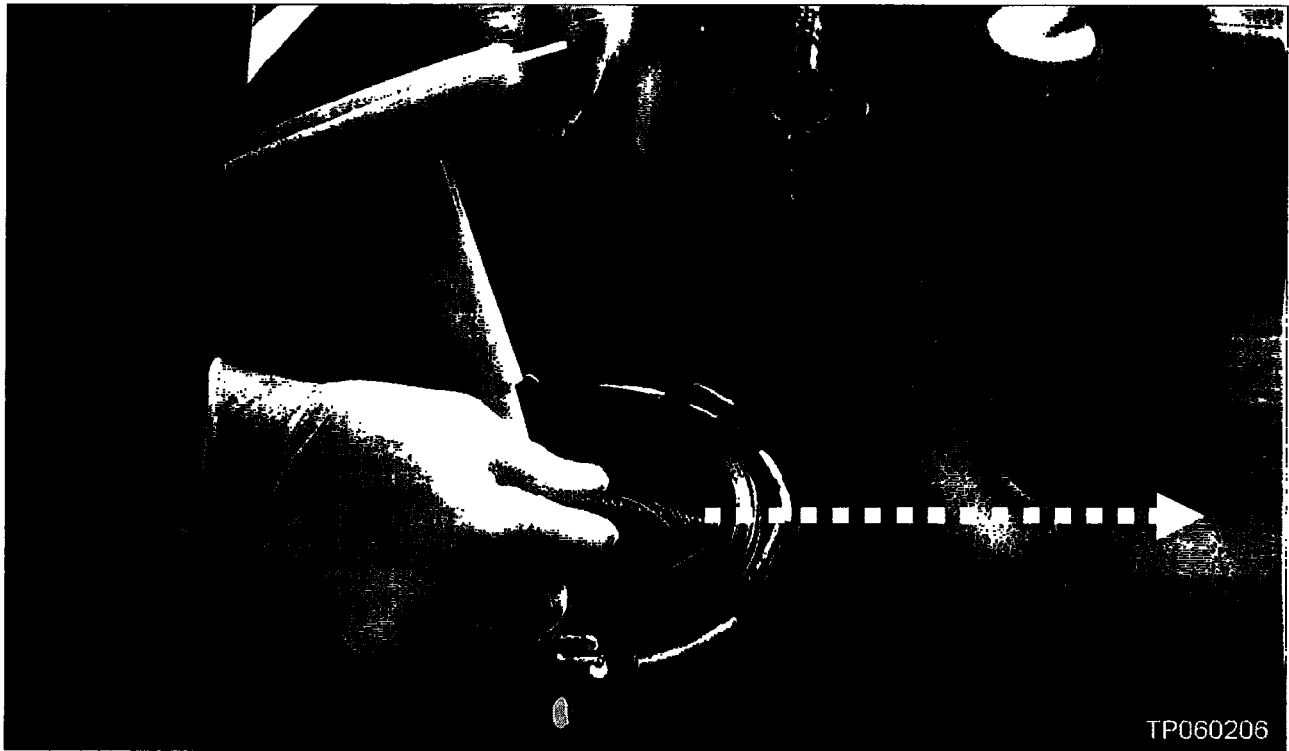

Figure 65

24. Fully install the sub fuel level sensor into the new tank.

25. Make sure the arrow on the tank and the arrow on the top of the sensor are aligned as shown in Figure 66.

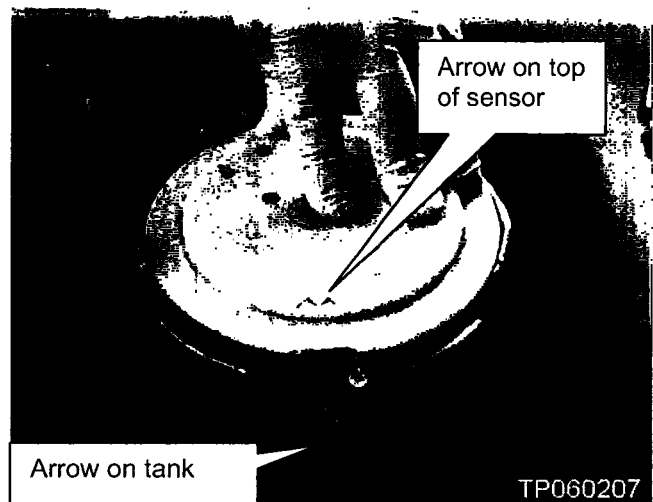

Figure 66



26. Install the lock ring on top of the sub fuel level sensor.

- Use fuel tank lock ring wrench, Special Tool J-46211.
- For additional information on the use of this special tool, see NTB02-126.

27. Install the new seal on the fuel pump opening of the new fuel tank.



Figure 67

28. Pull the fuel line out of the tank.

29. Connect the electrical connector shown in Figure 45.

30. Push the fuel line on until it snaps in place.

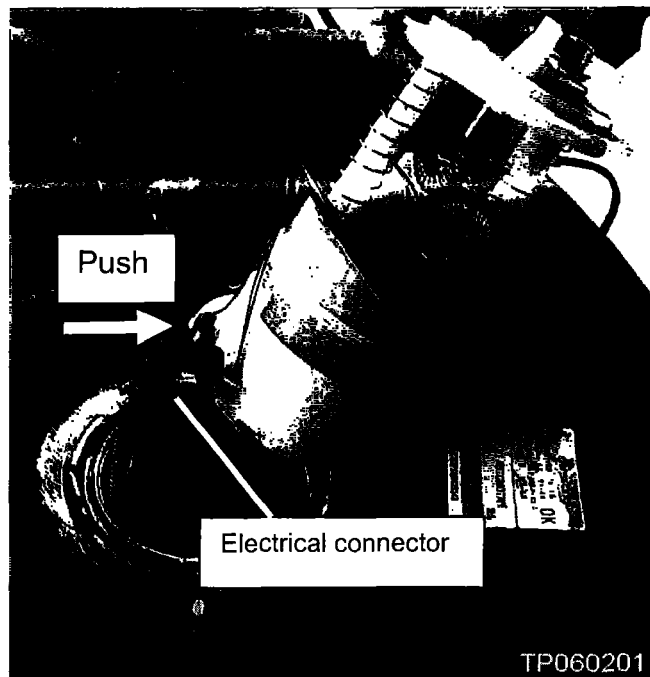

Figure 68

31. Install the fuel pump into the tank.

32. Make sure the arrow on the tank and the arrow on the top of the fuel pump are aligned as shown in Figure 69.

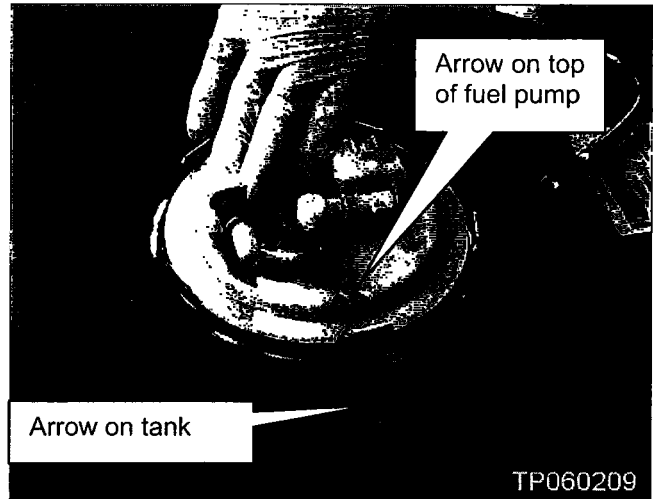

Figure 69

33. Install the lock ring on top of the fuel pump.

- Use fuel tank lock ring wrench, Special Tool J-46211.
- For additional information on the use of this special tool, see NTB02-126.

34. Swap the fuel fill hose from the old tank to the new tank.

- Line-up the mark on the hose with the mark on the tank (see Figure 70).

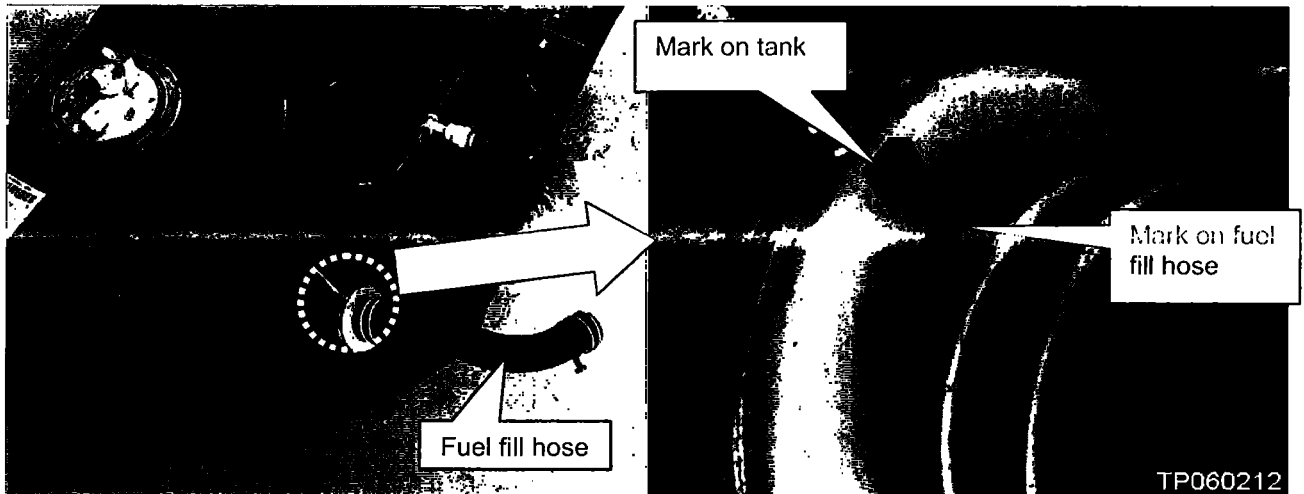

Figure 70

35. Tighten the fuel filler hose clamp at the tank so the distance between the bolt head and metal plate is set to the proper dimension (see Figure 71).

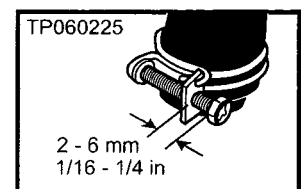

Figure 71

36. Swap the EVAP recirculation hose from the old tank to the new tank.

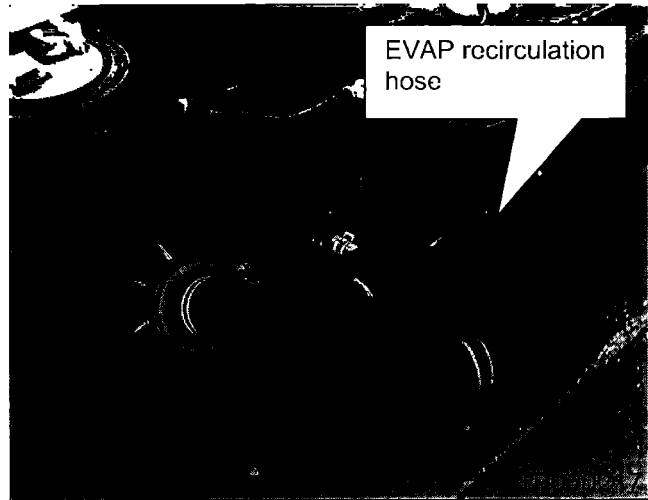

Figure 72

### Re-Assembly

37. Re-install all components in the reverse order of removal, making sure of the following:

- Tighten the fuel filler hose clamp at the fuel fill tube so the distance between the bolt head and metal plate is set to the proper dimension (see Figure 73).
- Use new gaskets at the front and rear of the center exhaust tube.

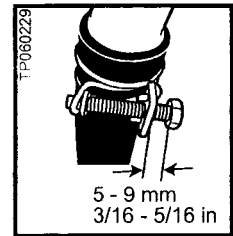

Figure 73

38. Re-connect the negative battery cable.

39. Re-program all radio station pre-sets.

40. Transfer the fuel from the old fuel tank to the new tank.

## PARTS INFORMATION

DESCRIPTION	PART NUMBER	QUANTITY
Fuel Tank Kit (Includes 2 seals; one for the sub fuel level sensor and one for the fuel pump)	17202-CC25A	1
Propeller Shaft Nut/Bolt Kit (for AWD models only)	37171-0P025	1
Gasket – Center Exhaust Tube Front	20692 – 65J00	1
Gasket – Center Exhaust Tube Rear	20691 – 30P00	1

## CLAIMS INFORMATION

Submit a Campaign (CM) line claim using the following claims coding:

“CM” I.D.: R0601

DESCRIPTION	OP CODE	FRT
RPL Fuel Tank (2 WD models)	R06010	2.0 hrs
RPL Fuel Tank (AWD models)	R06011	2.8 hrs

**NOTE:** Rear wheel alignment is not necessary.

## OWNER'S LETTER

Dear Nissan Owner:

This notice is sent to you in accordance with the requirements of the National Traffic and Motor Vehicle Safety Act. Nissan has decided that a defect that relates to motor vehicle safety exists in some 2005 model year Nissan Murano vehicles.

### Reason for Recall

There is the possibility that a vapor hose fitting attached to the fuel tank may come off. This will result in the malfunction indicator lamp (MIL) in the instrument panel coming on and may result in some fuel leakage. If an ignition source is present, a fire could occur.

### What Nissan Will Do

Your Nissan dealer will replace the fuel tank with a new one. This free service should take about four hours to complete, but your Nissan dealer may require your vehicle for a longer period of time based upon their work schedule.

### What You Should Do

Contact your Nissan dealer at your earliest convenience in order to arrange an appointment to have your vehicle repaired. Please bring this notice with you when you keep your service appointment. **It will be necessary that your fuel tank be no more than one-quarter full when you bring your vehicle to the dealer in order to minimize the possibility of fuel spill during the repair.** Instructions have been sent to your Nissan dealer. If you have additional questions you may contact the National Consumer Affairs Office, Nissan North America, Inc. at P.O. Box 191, Gardena, California 90248-0191. The toll free number is (800) 647-7261.

You may also submit a complaint to the Administrator, National Highway Traffic Safety Administration, 400 Seventh Street, SW., Washington, DC 20590; or call the toll-free Vehicle Safety Hotline at 1-888-327-4236 (TTY: 1-800-424-9153); or go to <http://www.safercar.gov>.

Federal law requires that any vehicle lessor receiving this recall notice must forward a copy of this notice to the lessee within ten days.

Thank you for your cooperation. We are indeed sorry for any inconvenience this may cause you.

