



Service Bulletin

MOTORCYCLE / ATV DIVISION

RECEIVED
395-21
2006 FEB -8 A 10:11
OFFICE OF
DEFECTS INVESTIGATION

4 - STROKE
VS/VX/VZ/VL BULLETIN NO. 34
DATE: 1/31/2006

**SAFETY RECALL CAMPAIGN
ALL 1998-2005 AND CERTAIN 2006 VL1500
AND C90/T BOULEVARD MODELS
FUEL TANK INSPECTION/REPLACEMENT**

SUBJECT: RECALL CAMPAIGN - FUEL TANK INSPECTION/REPLACEMENT

AFFECTED UNITS: All 1998-2005 and certain 2006 VL1500 and C90/T Boulevard models

**REFERENCE: VL1500 SERVICE MANUAL (PN 99500-39167-03E) WITH SERVICE
MANUAL SUPPLEMENT (PN 99501-39550-03E) OR
VL1500 SERVICE MANUAL (PN 99500-39168-03E)**

ATTACHMENT: CUSTOMER LETTER

NOTICE:

This notice is sent to you in accordance with the requirements of the National Traffic and Motor Vehicle Safety Act. Suzuki Motor Corporation has decided that a defect relating to motor vehicle safety exists in all 1998-2005 and certain 2006 VL1500 and C90/T Boulevard model motorcycles. Suzuki Motor Corporation is conducting a voluntary Safety Recall Campaign.

***STOP DELIVERY OF 1998-2005 AND CERTAIN 2006 VL1500 AND C90/T
BOULEVARD MODEL MOTORCYCLES IMMEDIATELY***

DO NOT DELIVER an affected **NEW** or **USED** 1998-2005 and certain 2006 VL1500 and C90/T model motorcycle to a customer until you have completed, or verified completion of, the procedures in this bulletin.

It is a violation of Federal law to deliver any new vehicle subject to a safety recall campaign under a sale or lease until the defect or noncompliance has been corrected. You must verify this on the Suzuki "Certificate of Vehicle Pre-Delivery" form, which is to be completed for all new and used vehicle sales.

WHAT IS THE PROBLEM?

Suzuki Motor Corporation has determined that under certain rare operating conditions, repeated stress around the right front fuel tank mounting point can cause a hairline crack to form due to metal fatigue. This can allow fuel seepage to occur. In the presence of an ignition source, seeped fuel can cause a fire.

WHAT WILL SUZUKI DO?

Suzuki is recalling affected units for inspection of the fuel tank and the installation of improved cushions that mount and support the fuel tank. An additional cushion rubber will also be installed between the lower front part of the fuel tank and the fuel tank frame support. These improved cushions better isolate the fuel tank to prevent vibration that could cause a stress crack in the fuel tank right front mount area. Any fuel tanks that are found to have a crack will be replaced.

AFFECTED UNIT VIN RANGES:

All 1998-2005 VL1500 and C90/T Boulevard models are affected. The VIN ranges of the affected 2006 motorcycles are listed below.

VL1500 (C90)	W	ALL
	X	ALL
	Y	ALL
	K1	ALL
	K2	ALL
	K3	ALL
	K4	ALL
	K5	ALL
	K6	JS1VY52A*62100003 ~ JS1VY52A*62104891
VL1500T (C90T)	K5	ALL
	K6	JS1VY52A*62100008 ~ JS1VY52A*62104951

NOTE: A notice stating that the recall repair has been performed will be included inside the shipping crate of all affected units shipped to dealers after 1/31/06.

WHAT YOUR DEALERSHIP WILL DO:

Notify your staff

Contact your customers; Please telephone all of your customers and inform them of the need to stop riding their motorcycles and to store the motorcycle in a well ventilated area away from any source of ignition (e.g. gas water heater, gas dryer etc.) until the fuel tank inspection/replacement campaign has been completed.

Notify American Suzuki about unregistered & out of reach units.

If you are aware of any affected units which have been scrapped, stolen or exported outside of the United States, please send this information to the Suzuki Warranty Department in Brea, CA.

WHAT YOUR DEALERSHIP WILL DO (CONTINUED):

CUSTOMER NOTIFICATION:

In the Safety Recall Campaign letter that will be mailed on February 3, 2006 (see attachment), customers are being advised to contact the Suzuki dealer where they purchased their affected unit to schedule an appointment to have the fuel tank inspected. As some customers may have moved to other communities since their motorcycle purchase, you may also receive calls from customers who purchased their motorcycle elsewhere. Once you are contacted by the owner of an affected unit, please arrange to order the Fuel Tank Cushion Modification Kit for the customer's motorcycle. Also, let your customers know that the Safety Recall Campaign service will be performed at no cost to them for parts and labor.

VERIFY THE UNIT REQUIRES THE RECALL REPAIR:

Before performing the recall inspection to a unit, verify that the inspection needs to be done. There are two ways to identify a unit that has already been inspected and repaired.

1. Check the repair status by checking the Vehicle History in the SCAT Service Menu. If the inspection needs to be performed to the motorcycle, you will see the message "CAMPAIGN NOT YET PERFORMED" displayed and the fuel tank will need to be inspected. Refer to the inspection procedure starting on page 6 of this bulletin.
2. Inspect the right side frame downtube for an identification punch mark located on the frame label at the end of the Vehicle Identification Number. If a punch mark is present the recall repair has already been performed.

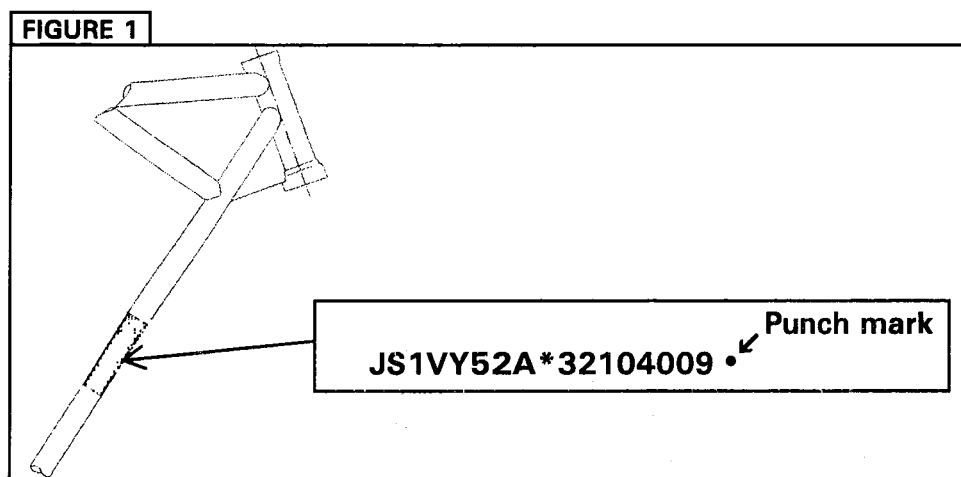

ORDERING PARTS FOR THE SAFETY RECALL CAMPAIGN:

You will be responsible for ordering the Fuel Tank Cushion Modification Kit for each unit you inspect and; if necessary, a Fuel Tank Replacement Kit for your customer's motorcycle using the corresponding part number below and your normal parts ordering methods. Do not order a Fuel Tank Replacement Kit until after you have inspected and determined that a crack exists.

IMPORTANT: Do not place an order using the part numbers from the EPC to perform this campaign! Use only these special campaign part numbers.

Fuel Tank Cushion Modification Kit Part Number 99103-11207 Dealer Price \$20.00 The Fuel Tank Cushion Modification Kit contains:		
	Part name	Qty
1	Cushion (fuel tank front mount)	2
2	Spacer (fuel tank front mount)	2
3	Cushion (fuel tank support, t 2.0)	1
4	Cushion (fuel tank support, t 4.0)	1
5	Cushion (fuel tank support, t 6.0)	1
6	Bolt (seat front)	2
7	Gasket (exhaust pipe)	1

One Fuel Tank Cushion Modification Kit will need to be ordered for every affected unit inspected.

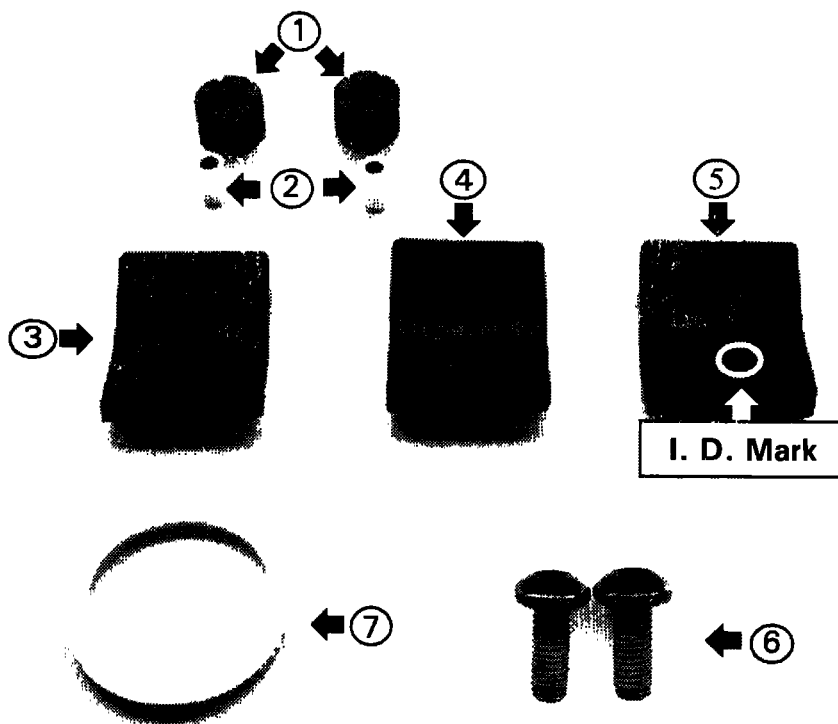

A Fuel Tank Replacement Kit will need to be ordered **ONLY** if the fuel tank is determined to be cracked on an affected unit during the inspection procedure.

Fuel Tank Kit Application Guide		
Part Number	Model	Price
99103-11208	VL1500W,X	239.37
99103-11209	VL1500Y/K1/K2/K3/K4	239.37
99103-11210	VL1500K5/K6	286.17

Fuel Tank Replacement Kit Contents			
	Part name	Qty	Remarks
	1 Fuel tank	1	*
	2 Molding (fuel tank)	2	All year models
	3 Cushion, lower (fuel tank rear mount)	2	All year models
	4 Cushion, upper (fuel tank rear mount)	2	All year models
	5 Fuel tank inlet valve	1	All year models
	6 Fuel shut-off valve	1	All year models
**	7 Cushion (fuel filter)	1	W/X/Y/K1/K2/K3/K4
**	8 Gasket (fuel gauge)	1	W/X/Y/K1/K2/K3/K4
**	9 O-ring (fuel pump)	1	K5/K6

* Only the fuel tank is different among the three Fuel Tank Kits. Should you determine that the fuel tank is cracked on an affected unit, order the Fuel Tank Kit using the appropriate part number per the Fuel Tank Kit Application Guide.

**These items are only required for the applicable models.

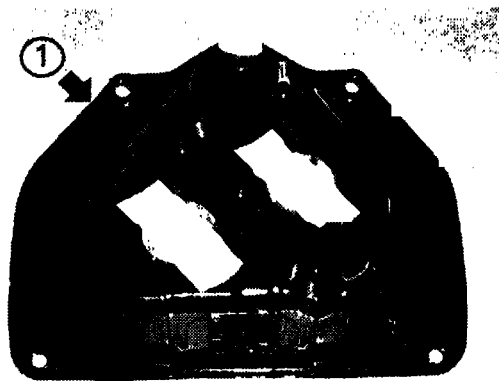

All parts needed to replace the fuel tank are included when a Fuel Tank Replacement Kit is ordered.

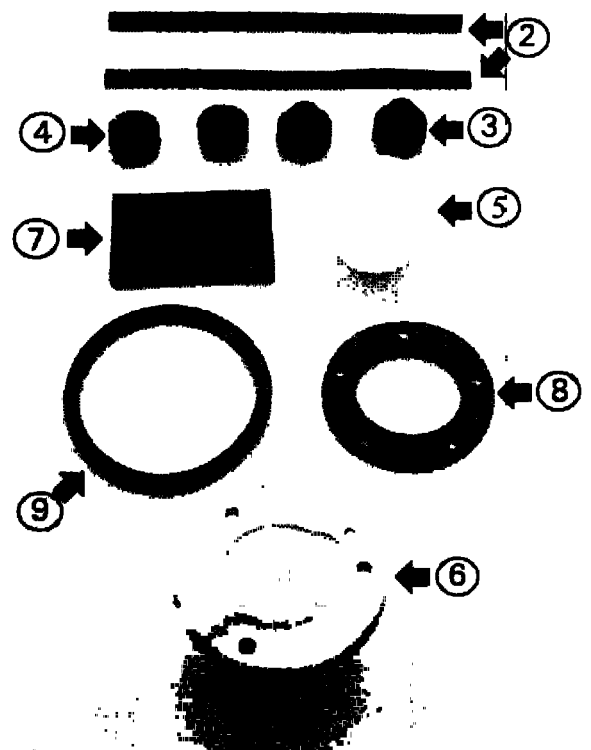

SHIPPING:

All parts will be shipped to you via UPS Ground unless otherwise specified at the time of order.

INSPECTION PROCEDURE (Test the fuel tank for cracking):

⚠ WARNING

When working with the fuel system, make sure to work in a well ventilated area away from any flame or ignition sources. Store the motorcycle in an area away from any flame or ignition sources.

1. Remove the seat. For VL1500 models earlier than K4, there is no need to remove the pillion (passenger) seat before removing the front seat. (Refer to Service Manual, Page 6-2)

2. Remove the frame covers. (Refer to Service Manual, Page 6-2)

Note: For new units in dealer inventory that have not been ridden it is not necessary to perform the inspection. Proceed to the Installation of the Fuel Tank Cushion Modification Kit on Page 7, Step 1.

3. Disconnect the hose ① at the fuel-vapor separator/fuel shut-off valve on the fuel tank.

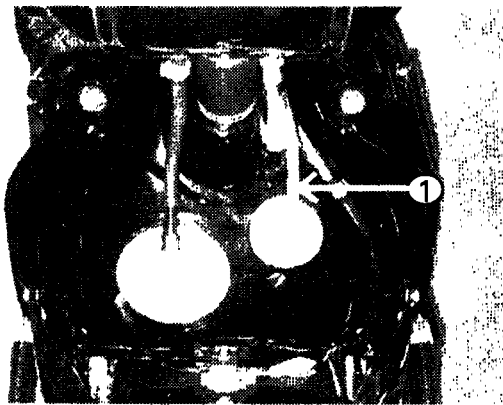

4. Connect the hand pump hose between the positive pressure side of the pump and the fuel-vapor separator/fuel shut-off valve.

 Suzuki Vacuum/Pressure Tester
(PN 99923-06824-001)

Note: Make sure the fuel tank cap is closed during the inspection.

Note: Number of hand lever strokes to be applied for the inspection:

When the fuel tank is half full or more:
approximately 50 strokes.

When the fuel tank is less than half full:
approximately 100 strokes.



Approximately 16cc per stroke is pumped when using the Suzuki Vacuum/Pressure Tester (99923-06824-001). When using other types of hand-operated pressure pumps, supply an equivalent volume of air as when using the Suzuki Vacuum/Pressure Tester. Monitor the pressure. Never exceed 4.2 psi.

⚠ WARNING

Never use compressed air or a foot-operated pressure pump. Excess pressure may cause parts breakage and personal injury. Pressure over 4.2 psi may deform the fuel tank or create the possibility of a fuel leak.

INSPECTION PROCEDURE (CONTINUED):

5. Apply soapy water to the welded area at the right front mount area of the fuel tank. Supply air to the fuel tank with a hand-operated pump and inspect for air leakage. The picture shows air bubbles forming on a cracked fuel tank.

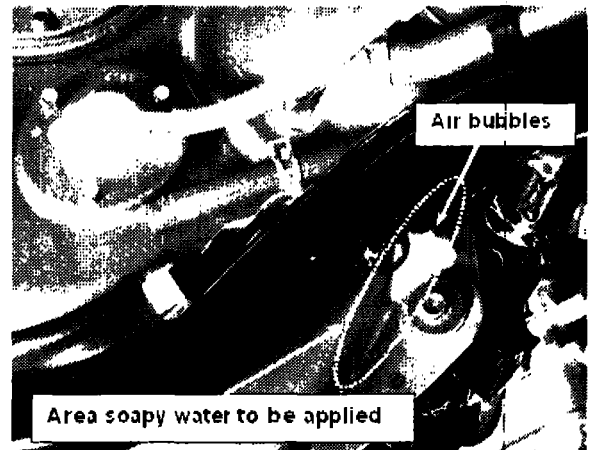

If air bubbles do not form on the fuel tank, proceed to Installation of the Fuel Tank Cushion Modification Kit below. If air bubbles do form on the fuel tank, proceed to Installation of the Fuel Tank Replacement Kit on Page 11.

Installation of the Fuel Tank Cushion Modification Kit

1. Remove the upper muffler. (Refer to Service Manual, Page 3-5)
2. Remove the lower muffler mount bolts for easy removal of the rear exhaust pipe.

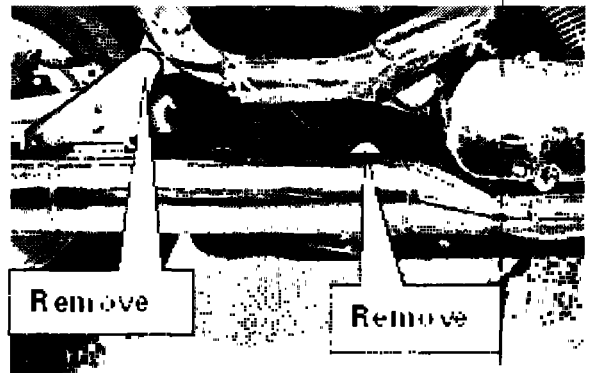

3. Loosen the muffler connector bolts.

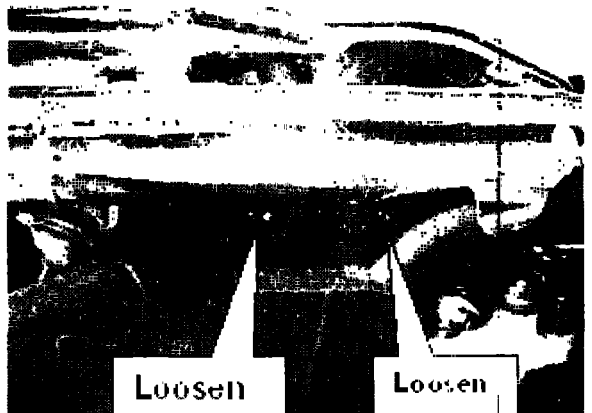

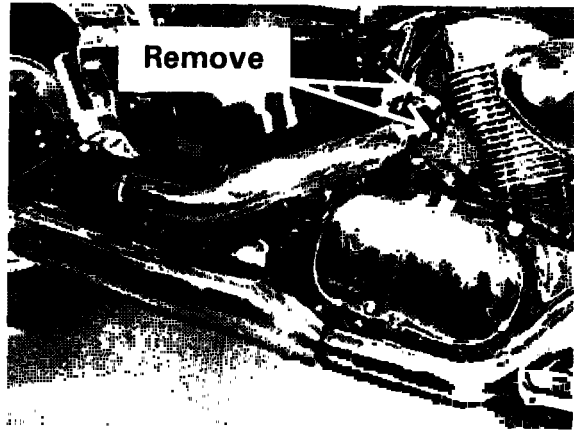

INSTALLATION OF THE FUEL TANK CUSHION MODIFICATION KIT (CONTINUED):

4. Remove the exhaust pipe clamp nuts at the cylinder head. Remove rear exhaust pipe.

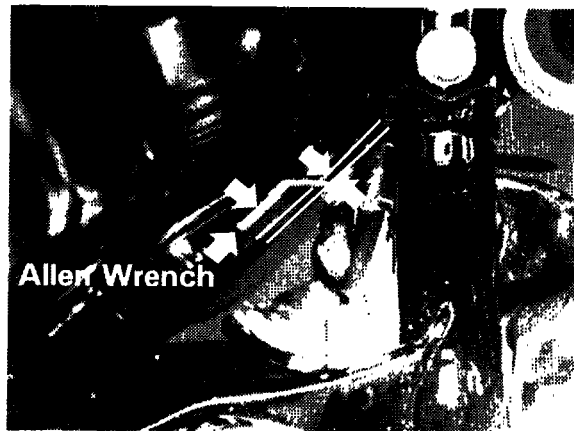

5. Measure the clearance between the fuel tank lower body and the cushion on the frame bracket by inserting feeler gauges and/or an Allen wrench (3 or 4mm) into the clearance. Slide the feeler gauge/Allen wrench into the space 15mm up from the bottom of the cushion (see Figure 2), and determine which feeler gauge/Allen wrench produces a slight resistance when measuring.



Note: Make sure to use the hexagon face side for the measurement. 

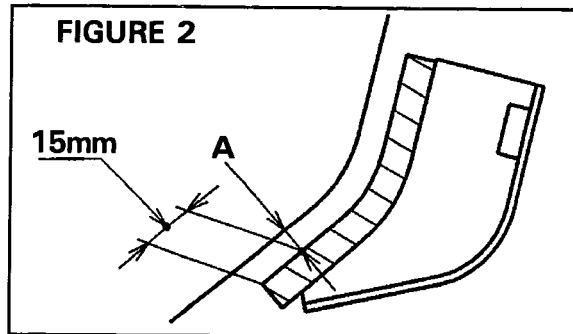

A: Clearance to be measured

Select the correct fuel tank support cushion to install.

Measured Clearance	Cushion to be used
Less than 1mm	Use the cushion marked "2"
1 to 3mm	Use the cushion marked "4"
More than 3mm	Use the cushion marked "6"

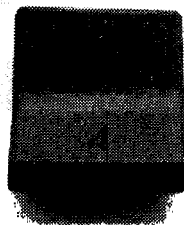
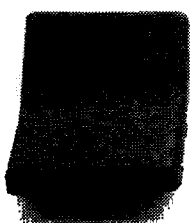

INSTALLATION OF THE FUEL TANK CUSHION MODIFICATION KIT (CONTINUED):

6. Open the fuel lid and remove the four screws at the fuel inlet area and two screws in front of the meter cover.

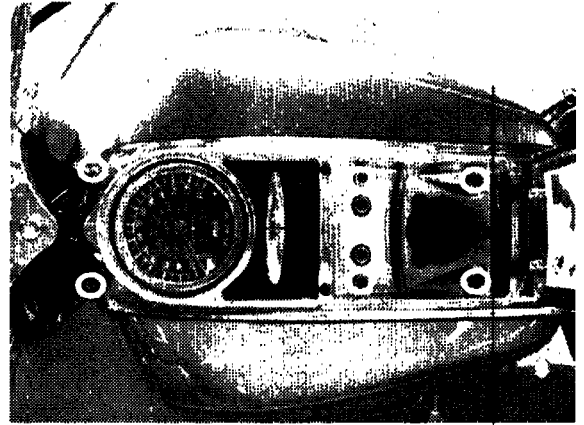

7. Remove the two mount bolts at the front of the fuel tank. Loosen the two bolts at the rear of the fuel tank by approximately 5mm.

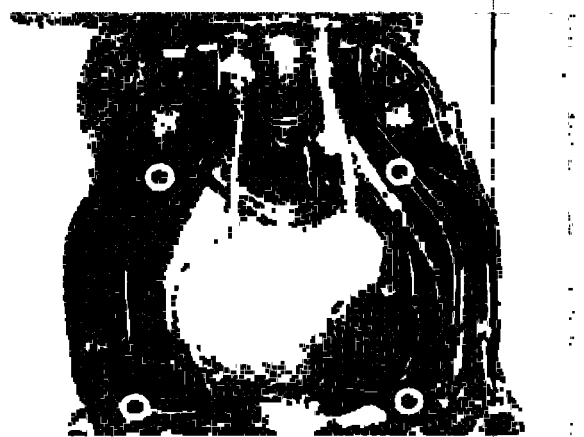

8. Lift the fuel tank to produce clearance to insert the fuel tank support cushion.

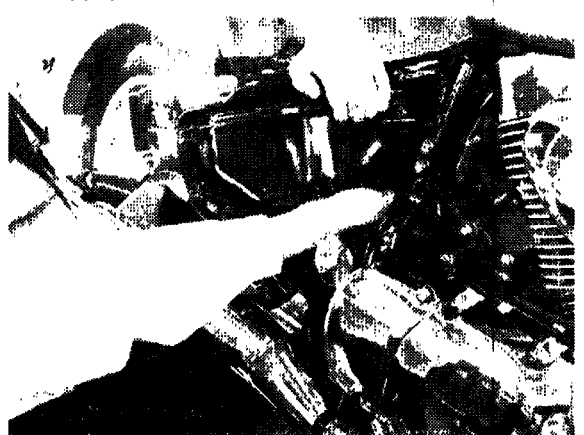

9. Apply soapy water to both sides of the fuel tank support cushion, and slide the cushion into the proper position on top of the original cushion.



CAUTION

Make sure to place the new cushion outer lip over all edges of the original cushion.

INSTALLATION OF THE FUEL TANK CUSHION MODIFICATION KIT (CONTINUED):

10. Replace the original mount cushions and spacers with the modified ones.

Note: If you install the 2mm or 4mm support cushion, before tightening the front fuel tank mount bolts check for a clearance of 1mm or more between the new mount cushion and the base of the fuel tank mount bracket. If the clearance is less than 1mm, replace the support cushion with the next thicker one to increase the clearance to more than 1mm.

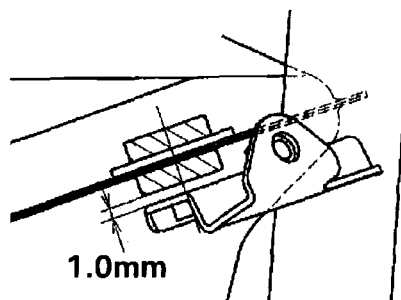
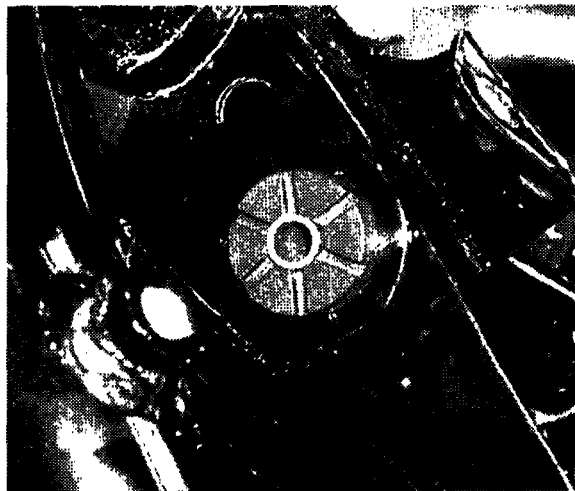

11. Reassemble the parts in the following order:

- Connect the fuel hose to the fuel-vapor separator/fuel shut-off valve.
- Install the fuel tank mount bolts and meter cover screws.
- Install the exhaust pipe using a new gasket.
- Tighten the bolts at the bottom of the muffler.
- Install the upper muffler and tighten bolts and nuts.
- Install the frame covers, front seat and pillion seat.

For torque specifications, refer to Service Manual (Pages 8-26 through 8-29)

Place an identification punch mark on the frame label just after the Vehicle Identification Number per Figure 3 to confirm that the recall service has been completed. The frame label is located on the right side downtube.

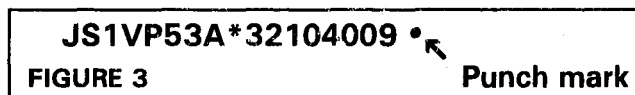

Installation of the Fuel Tank Replacement Kit

If the fuel tank was determined to be cracked during inspection, replace the fuel tank.

1. Replace the fuel tank using the Fuel Tank Replacement Kit (Refer to Service Manual, Page 5-2).
Before installing the Fuel Tank, be certain that the Kit is correct for the model year of motorcycle being repaired. (See Fuel Tank Replacement Kit Application Guide, Page 5 of this bulletin).
2. Install parts #2 through #9 in the Fuel Tank Kit, as the parts from the original fuel tank are not reusable.
3. Install Fuel Filter Cushion on 1998-2004 models only. Remove the protective sheet from the adhesive side and apply to the fuel tank as shown.

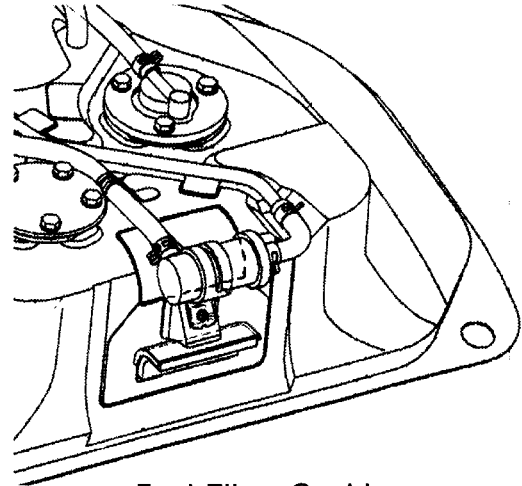

Fuel Filter Cushion
(1998-2004 models only)

4. Temporarily install and tighten fuel tank mount bolts.
5. Install the Fuel Tank Cushion Modification Kit following the procedure beginning with Step 5 on Page 8/14 of this bulletin.

WARRANTY REIMBURSEMENT & CLAIM INFORMATION:

Inspection/Repair Performed	Hrs.
Inspection and Installation of Fuel Tank Cushion Modification Kit	1.0
Inspection, Installation of Fuel Tank Cushion Modification Kit and Fuel Tank Replacement Kit	2.0

Use the Short Form for the Fuel Tank Inspection and Cushion Kit Installation Only

RECALL CAMPAIGN FUEL TANK CUSHION MODIFICATION KIT SCAT Short Form Instructions	
CLAIM NUMBER:	Dealer enters number
ENTRY TYPE:	Model, Frame
(Dealer Chooses)	Control Sequence
	VIN
REPAIR DATE:	Enter date of repair
MILEAGE:	Enter mileage on unit
CAMPAIGN:	2087

WARRANTY REIMBURSEMENT & CLAIM INFORMATION (CONTINUED):

Use the Long Form When Fuel Tank Replacement is Required (Includes Cushion Kit Installation)

RECALL CAMPAIGN FUEL TANK INSPECTION KIT/REPLACEMENT KIT SCAT Long Form Instructions	
CLAIM NUMBER:	Dealer enters number
ENTRY TYPE: (Dealer Chooses)	Model, Frame Control Sequence VIN
REPAIR DATE:	Enter date of repair
MILEAGE:	Enter mileage on unit
CAMPAIGN:	2087
CAMPAIGN PART:	99103-11207
ADDTL. PART NUMBERS:	Campaign Fuel Tank Kit PN
COMPLAINT CODE:	2087
DEFECT CODE:	JJ
LABOR OPERATION:	DH9999
LABOR TIME:	2.0, or as approved by TECH-LINE
FAILURE DESCRIPTION:	INSPECT/REPLACE FUEL TANK PER CAMPAIGN

SCAT Long Form warranty claim entries with additional parts or labor require a prior authorization (PAS) code from TECH-LINE or your Technical Service Manager, or the SCAT system will not accept the claim.

IMPORTANT:

Successful completion of this safety recall campaign depends on your efforts. It is your responsibility to repair any motorcycle within the affected VIN range at no cost to the customer for recall service parts and labor. Incidental costs your customers may incur are not normally covered. However, if you have a customer with special needs, contact your Technical Service Manager (800/756-3251) to discuss possible solutions.

AFFECTED DEPARTMENTS:

The following departments in your dealership should be notified of this information:

Management Service Warranty Sales Parts Accessories

American Suzuki Motor Corporation
Technical Service Department
Motorcycle / ATV



AMERICAN SUZUKI MOTOR CORPORATION
MOTORCYCLE

February 3, 2006

**SAFETY RECALL CAMPAIGN
ALL 1998-2005 AND CERTAIN 2006 VL1500
AND C90/T BOULEVARD MODELS
FUEL TANK INSPECTION/REPLACEMENT**

Dear Suzuki Owner:

This notice is sent to you in accordance with the requirements of the National Traffic and Motor Vehicle Safety Act.

What is the reason for this notice?

Suzuki Motor Corporation has decided that a defect relating to motor vehicle safety exists in all 1998-2005 and certain 2006 VL1500 and C90/T Boulevard model motorcycles. Suzuki Motor Corporation is conducting a voluntary Safety Recall Campaign. According to our records, you are the owner of one of these motorcycles.

What is the problem?

Suzuki Motor Corporation has determined that under certain rare operating conditions, repeated stress around the right front fuel tank mounting point can cause a hairline crack to form due to metal fatigue. This can allow fuel seepage to occur. In the presence of an ignition source, seeped fuel can cause a fire.

▲ WARNING

**SUZUKI STRONGLY RECOMMENDS THAT YOU DO NOT RIDE YOUR
AFFECTED 1998 ~ 2006 VL1500 OR C90/T BOULEVARD MOTORCYCLE
UNTIL THE REPAIR HAS BEEN COMPLETED**

To minimize the risk of injury or death, do not ride, or allow anyone else to ride, your motorcycle. We also recommend that you store your motorcycle in a well ventilated area away from any source of ignition (e.g. gas water heater, gas dryer etc.) until your motorcycle has been repaired by your Suzuki dealer.

What is Suzuki doing to solve the problem?

Suzuki is recalling affected units for inspection of the fuel tank and the installation of improved cushions that mount and support the fuel tank. These improved cushions better isolate the fuel tank to prevent vibration that could cause a stress crack in the fuel tank right front mount area. Any fuel tanks that are found to have a crack will be replaced. Repair time is approximately 2 hours and will be done at no cost to you for parts or labor.

How do I receive the fastest possible service?

Suzuki understands that your riding time is precious. Our suggestion is to work closely with your authorized Suzuki dealer to get your motorcycle's recall service scheduled and performed as quickly as possible. Schedule an appointment for the recall service to be performed. Parts are currently available. It will be necessary for your dealer to order the parts. It may be necessary to leave your motorcycle with the dealer overnight, so check with your dealer.

CUSTOMER NOTIFICATION LETTER - Page Two of Two

When you pick up your repaired motorcycle, please allow a few extra minutes for your dealer to prepare and complete the necessary warranty paperwork with you. If you have special circumstances, discuss them with your Suzuki dealer. Suzuki understands that some customers may have difficult circumstances to overcome in bringing their motorcycle to the dealership for repair. We have asked your Suzuki dealer to work closely and flexibly with you to arrange alternative, but reasonable solutions for your special requests. Please remember, however, that each dealership has its own limitations in providing special assistance due to staff size, available time, and dealership location. Your dealer can also consult with Suzuki on other alternatives.

Questions & Answers

Your Suzuki dealer has been provided specific and complete instructions regarding this recall service. Please call your dealer if you have any questions. Your local Suzuki dealer can provide the fastest responses to your questions or concerns about the recall service. Your dealer can also contact Suzuki on your behalf if you have a unique question or concern.

If you have difficulty having the recall service performed on your motorcycle you may contact the American Suzuki Customer Service Department for assistance at 714-572-1490. You will need to have your Vehicle Identification Number ready when calling.

If you believe that (1) Suzuki or your Suzuki dealer has failed to or is unable to perform the recall service without charge, or (2) Suzuki has failed to or is unable to perform the recall procedure to your vehicle within 60 days after you first brought your vehicle to your Suzuki dealer after February 3, 2006 you may submit a complaint to the Administrator, National Highway Traffic Safety Administration, 400 Seventh Street, S.W., Washington, D.C. 20590 or call the toll free Vehicle Safety Hotline at 1-888-327-4236 (TTY: 1-800-424-9153); or go to <http://www.safercar.gov>.

Locating an alternate dealer

Suzuki dealers can be located on the internet at www.suzukicycles.com or by calling 1 (800) 828-7433.

Customer Reimbursement

If your motorcycle is included in the recall and you have paid for the repair or replacement of the fuel tank due to a crack in the right front mount area, you may be eligible for full or partial reimbursement. Please note the following for which Suzuki may exclude reimbursement:

- Only repairs that are the subject of the safety recall are reimbursable. Additional expenses such as towing, rental, accommodations, damage repairs, etc. will not be reimbursed.
- Reimbursement may be limited to suggested list price on parts and the Suzuki published flat rate time allowance.
- An owner will not be eligible for reimbursement if the expenses for repairs are incurred more than 10 days after the date of the last owner notification letter sent by Suzuki.
- Reimbursement claims may also be excluded when you do not submit adequate documentation. Your authorized Suzuki dealer will request an original or copy of your receipt for the recall repair or replacement, and your owner notification letter.

To obtain information or request reimbursement, contact your Suzuki dealer or the American Suzuki Motor Corporation Motorcycle Customer Service Department, PO Box 1100, Brea, CA 92822-1100, or call (714) 572-1490. You will need to have your Vehicle Identification Number ready when calling.

We thank you for your prompt attention to completing this recall service on your Suzuki motorcycle. We apologize for any inconvenience this campaign causes you. Your safety, satisfaction, and riding enjoyment are priorities for Suzuki.

Sincerely,

American Suzuki Motor Corporation