

IC Corporation

751 South Harkrider, Conway, Ar 72302

A SUBSIDIARY OF INTERNATIONAL
TRUCK AND ENGINE CORPORATION

SAFETY RECALL 06512

February, 2007

Dear IC Corporation Customer:

This notice is sent to you in accordance with the requirements of the National Traffic and Motor Vehicle Safety Act. IC Corporation has decided that a defect which relates to motor vehicle safety exists in certain BE, CE, FE, and RE school and commercial buses built between October 11, 2005 and October 31, 2006 with property codes 0048VUK, 0048VUJ, 0048VUP, and 0048VUR. The vehicle identified on the enclosed green card fits this description and our records show that you own this vehicle. Federal regulations require that any vehicle lessor receiving this recall notice must forward a copy of this notice to the lessee within ten days.

REASON FOR THIS RECALL

There are four issues that may exist for the National Seat ABTS (All Belts To Seat) driver's seat that this recall will remedy.

- For Air and Manually Adjustable ABTS Seats:
 - The driver's seatbelt retractor may not work properly if the seat back is pushed against a barrier or other objects behind the driver's seat.
- For Manually Adjustable ABTS Seats:
 - The driver's seat may be pulled upward past the last seat adjustment position.
 - The seat and adjustment handle may pinch the driver's hand when the seat is adjusted while the driver is sitting on it.
 - The driver's seat may be difficult to raise to a higher position due to its weight.

RISK TO MOTOR VEHICLE SAFETY

- Failure of the seatbelt to retract may affect the safety of the driver in case of an emergency stop or collision.
- If over-travel of the seat occurs, the upper seat pedestal tube could separate from the lower pedestal tube during vehicle operation.
- The seat dropping during height adjustment and the additional weight of the ABTS seat and driver during height adjustment may result in personal injury.

ACTIONS YOU SHOULD TAKE

1. Until repairs can be completed, caution should be taken to avoid the situations described. If your seat does not have the warning label shown below, you may request one with your parts and affix it to the seat as shown below. Please indicate that you need the label when you order parts. This label advises to adjust the seat height only while standing beside the seat, not while sitting.

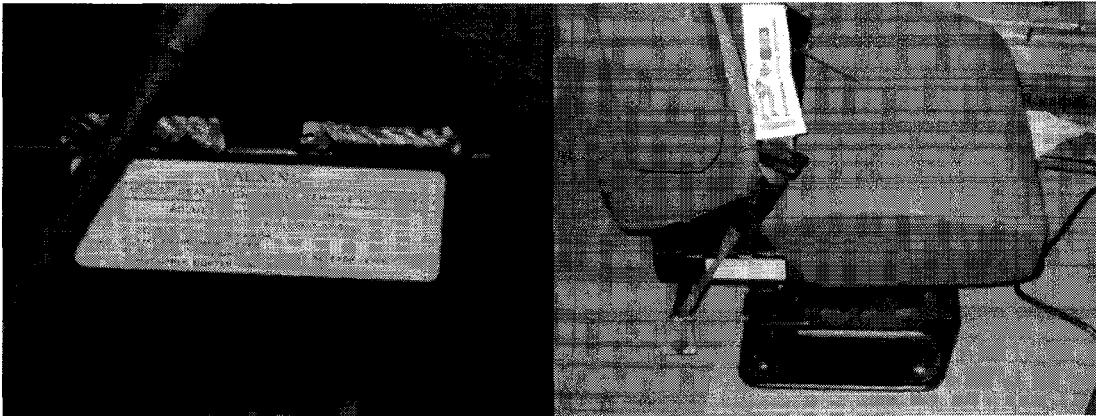

2. **Our records show that you are the owner** of the vehicle identified on the enclosed card. **If you are not the owner**, please read paragraph number 7.
3. If you would like your IC dealer to make this inspection and repair for you at no cost, **please contact your local IC dealer**. To have your vehicle repaired, provide your dealer with your green recall card and schedule an appointment.
4. If you prefer to inspect and repair the vehicle yourself, the repair instructions are outlined in the Repair Procedure section below.

To order parts, fill out and return the enclosed green recall card with box # 8 checked and our Compliance Department will have the parts shipped directly to you at no charge. Please verify that your shipping address is correct. A Post Office Box (P.O. Box) number for shipping is not acceptable. We must have a street or road address. You may also obtain these parts by faxing a request to 1-501-505-2433 or emailing to shawn.finkbeiner@ic-corp.com. If you have multiple VINs that fall within this recall, a fax is the preferred method. The last eight characters of the VIN of each unit to be repaired must be included.

5. IC dealers will have instructions to make the repair by 02/09/2007. The repair will be performed without charge to you and will take approximately 1 hour per seat. Have your dealer verify and correct your address, if necessary.
6. If the **vehicle will not be corrected or cannot be corrected**, please mark on the enclosed card under "CHECK ONE" the box which best describes why the vehicle will not be repaired, and return the postage-prepaid card to us.

7. **In the event you do not own the vehicle** described on the card, please complete the card, fill in the new customer name and address if known, and return it to us. This information will allow us to update our records so we can contact the new owner and you will not be contacted again regarding this recall.

Any correspondence must be addressed to IC Corporation, PO Box 6000, Conway, Arkansas, 72033, Attn: Compliance Department. If you need to contact IC Corporation, please email Shawn Finkbeiner at shawn.finkbeiner@ic-corp.com.

REIMBURSEMENT OF REPAIRS
COMPLETED PRIOR TO THE RELEASE OF THIS RECALL

If you paid to repair your vehicle for this defect prior to receiving this recall letter, you may be eligible for reimbursement of the repair costs if the costs were incurred between 11/01/2005 and 02/28/2007. Contact your local International dealer, with your original repair documentation and proof of payment, and the service advisor will determine what if any of the repair costs will qualify for reimbursement. International dealers determine what repair costs are eligible for reimbursement. However, if you choose not to work through an International dealer, you may submit the enclosed "REQUEST FOR REIMBURSEMENT" form, repair documentation, and proof of payment to:

International Truck and Engine Corporation
Warranty Claim Center Reimbursement Department
P.O. Box 888
Warrenville, IL 60555

RECALL CLAIMS

For Repairs Performed By Customer or Non-Authorized IC Dealers

To assist in processing the recall, it is important that you provide an invoice with the following information.

VIN # (or List of VINs repaired)
Recall Campaign #06512
SUBJECT (National ABTS Seat)
Facilities Repair Labor Rate
Labor Operation Numbers
Your Tax ID Number
Hours to Repair

All correspondence must be returned to IC Corporation, PO Box 6000, Conway, Arkansas, 72033, Attn: Compliance Department.

IF YOU NEED ASSISTANCE

If you take your vehicle to your dealer on a mutually agreed upon service date, and the dealer does not remedy this condition without charge on that date or within five days, you can obtain assistance by following the procedure described in the Owner Assistance Guide section in your Owner's Manual or by calling toll free 1-800-448-7825.

You may also wish to submit a complaint to the Administrator, National Highway Traffic Safety Administration, 400 Seventh Street, S.W., Washington, D.C., 20590, or call the toll-free Vehicle Safety Hot-Line at 1-888-327-4236 (TTY: 1-800-424-9153); or go to <http://www.safercar.gov> if your IC Dealer fails to repair or is unable to remedy this condition without charge or within a reasonable time.

We request your prompt attention to the correction of this defect and apologize for any inconvenience this may cause you.

PARTS INFORMATION

Kit Part Number	Description
8900192R91	National Drivers Seat – Seatbelt Retractor Cover Kit (Air & Manual Seats) – for repair 1
8900197R91	National Drivers Seat - Manual Seat Kit (Lever, Spring, Tether) – for repairs 2, 3, & 4

REPAIR PROCEDURES



WARNING:

TO AVOID SERIOUS EYE INJURY, ALWAYS WEAR SAFE EYE PROTECTION WHEN YOU PERFORM VEHICLE MAINTENANCE OR SERVICE.



WARNING:

TO AVOID PROPERTY DAMAGE, PERSONAL INJURY, OR DEATH WHEN SERVICING THE VEHICLE, PARK ON A FLAT LEVEL SURFACE, SET THE PARKING BRAKE, SHUT THE ENGINE OFF AND CHOCK THE WHEELS.



WARNING:

TO AVOID PROPERTY DAMAGE, PERSONAL INJURY, OR DEATH WHEN SERVICING THE VEHICLE, THE FOLLOWING PROCEDURE MUST BE PERFORMED WITH THE LOWER SEAT BASE MOUNTED FIRMLY TO THE VEHICLE FLOOR. DUE TO THE SPRING FORCES PRESENT, THESE PROCEDURES **MUST NOT** BE PERFORMED WITH THE LOWER SEAT BASE REMOVED FROM THE VEHICLE.

PLEASE read all warnings, inspection, and repair instructions prior to starting the repair process. There are 4 separate repair and 1 inspection procedure. The setup and reassembly instructions for some procedures are the same. Some of these steps may be eliminated when moving from 1 repair to the next. Comments have been added when steps are affected by duplication in multiple procedures.

- 1) Repair 1 - Seatbelt Retractor
- 2) Repair 2 - Height Adjustment Lever
- 3) Repair 3 - Supplemental Spring
- 4) Inspection 1 – Inspect prior to Repair 4
- 5) Repair 4 - Non-adjustable Tether

NOTE: During the manufacturing process on manual seats without an up-stop mechanism, a plastic tie-strap is used to keep the seat height springs compressed (See FIGURE 1). Once the seat is assembled, this tie-strap must be removed to allow adjustment of the seat height. Before performing the following procedures, inspect the seat being modified and verify that the tie-strap has been removed. If necessary, remove the tie-strap.

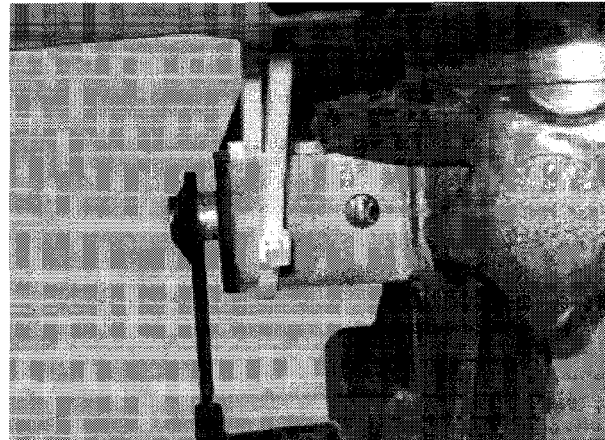

FIGURE 1.

Repair Procedure 1 – Seatbelt Retractor – All seats

1. Arrange the steering wheel and seat to allow access to rear of upper seat back, on driver's seat (seat should be in forward and upright position).
2. Remove any items stored behind the driver's seat.
3. Remove inside seat arm.
 - a. Access the armrest tube underneath the foam and seat cover, as shown in FIGURE 2.



FIGURE 2.

- b. Locate the button on the armrest by inserting the screwdriver under the seat cover and foam, and into the middle of the armrest tube. See FIGURE 3. (Arm rest is shown already removed in FIGURE 3.)

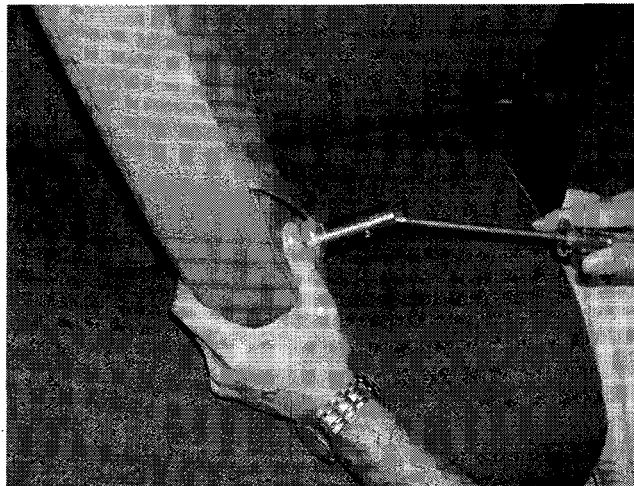

FIGURE 3.

- c. Twist the screwdriver to depress the retaining button located in the arm rest tube. See FIGURE 4.

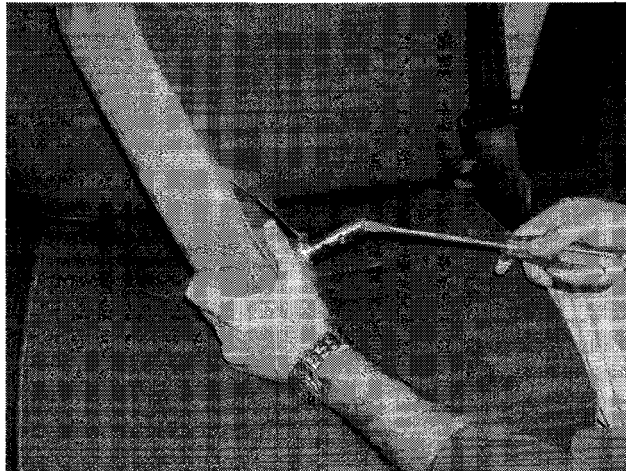

FIGURE 4.

4. Partially remove cover from upper seat back.
 - a. Front flap of cover is clipped to back flap of cover at bottom of seat back. The clip piece attached to the front flap must be pulled forward (rotated) to disconnect it from the clip piece attached to the back flap. See FIGURE 5.
 - b. Starting at the bottom, roll the cover up one or two rolls; then, grasping the rolled material, slip the cover upward until the upper left corner of the seat back is exposed. See FIGURES 6 & 7.



FIGURE 5. Two Piece Clip for Seat Back Cover (Rotate to Disengage)

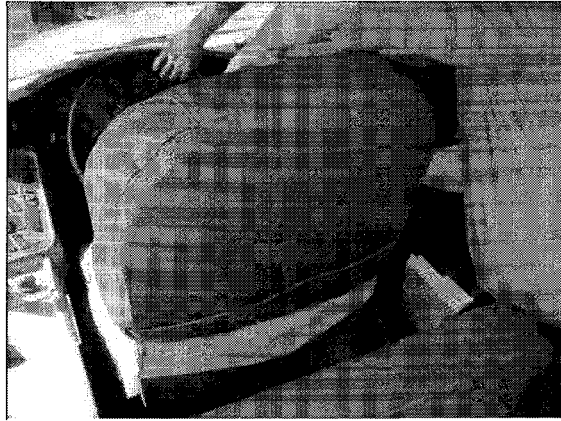

FIGURE 6.

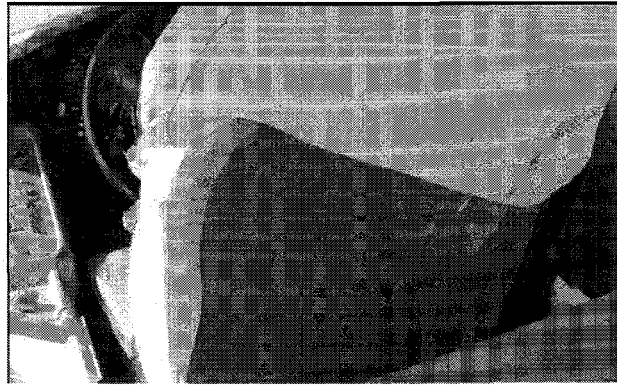

FIGURE 7.

5. Starting at the upper back of the seat back, ***carefully*** pull the grey foam away from the left side of the seat back just enough to expose the top of the seat belt channel on the rear of the seat. The grey foam is attached with adhesive. See FIGURE 8.

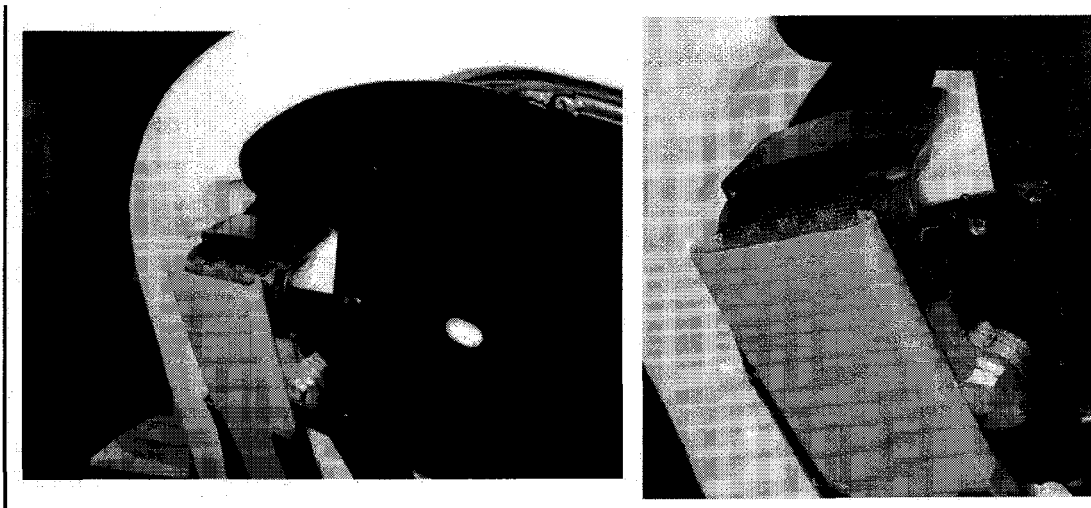

FIGURE 8. Seat Belt Channel and Guide (Grey Foam Removed for Clarity)

NOTE: In the following steps, the new seat belt guard is used as a template to mark and drill two holes. Do not mark the holes until the guard is correctly positioned. Mark the holes with a center punch before drilling, to prevent the drill bit from 'walking'.

6. Position the belt guard so that its top flange is over the top of the black plastic belt guide and the guard is not touching the seat belt. This should position the right side hole approximately $\frac{1}{4}$ inch below the edge of the bracket being drilled. Mark the location with a center punch and drill an $\frac{11}{64}$ inch diameter hole. Install the right side screw (provided in kit), but leave the screw loose enough to allow some movement of the guard. See FIGURES 9 and 10.



FIGURE 9.



FIGURE 10.

7. Using the guard as a guide, drill an $\frac{11}{64}$ inch diameter hole for the left side screw. Install the provided screw.

8. Tighten both screws. See FIGURE 11.

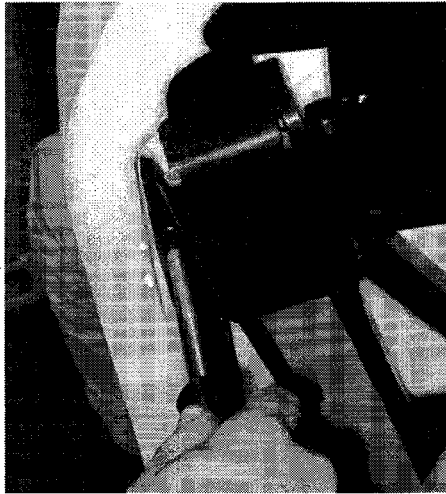

FIGURE 11.

NOTE: In the following step duct tape may be used, if necessary, to secure the grey foam and prevent it from shifting while installing the seat cover.

9. Return the grey foam to its original position, then slide the seat cover down the seat back.
10. Stretch the cover to reconnect the clips attached to the front and back cover flaps at the bottom of the seat back. Insert the front flap clip into the groove of the back flap clip until the clip barb is engaged. See FIGURE 5.
11. Replace arm.
12. Add sticker that indicates that recall has been performed on seat belt retractor. See FIGURE 12.

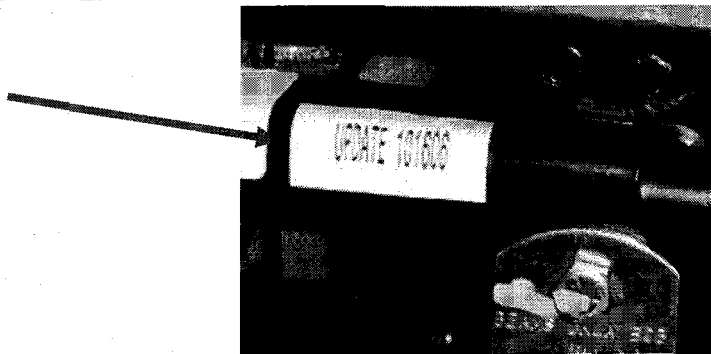
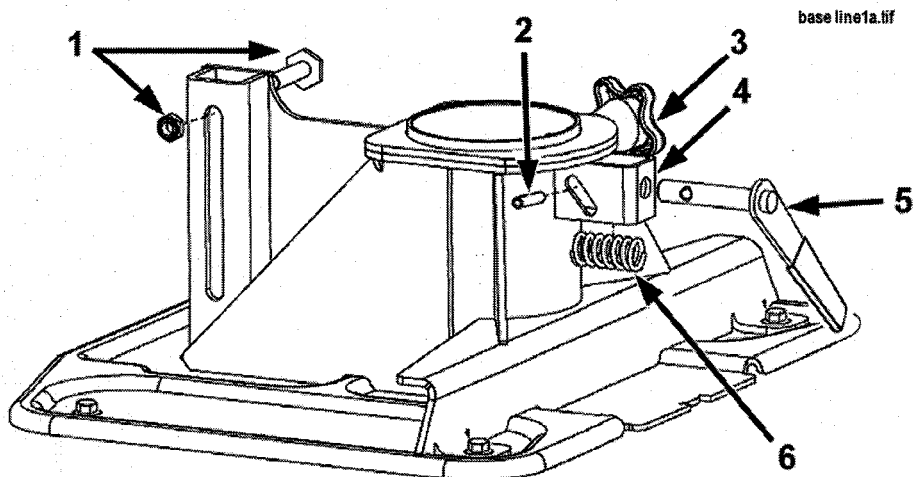

FIGURE 12.

End of Repair Procedure 1

Repair Procedure 2 - Seat Height Lever Replacement – Manual Seats

1. Disconnect any seat-to-floor tethers by unbolting them from the **seat**. **DO NOT** unbolt the tethers from the vehicle floor. Step 1 is also required to prepare for Repair Procedure 3.
2. If the seat is equipped with an up-stop mechanism, remove the limiting bolt and nut. See FIGURE 13. Retain this hardware for use during assembly. Step 2 is also required to prepare for Repair Procedure 3.
3. Loosen the seat height adjustment lock knob enough to allow seat height adjustment. Step 3 is also required to prepare for Repair Procedure 3.



1. UP-STOP MECHANISM BOLT AND NUT
2. ROLL PIN
3. SEAT HEIGHT ADJUSTMENT LOCK KNOB
4. SPRING CAGE
5. SEAT HEIGHT PIN / LEVER
6. TENSION SPRING

FIGURE 13.

4. With seat height lever raised to disengage, lift upper seat assembly off of lower base. Set the upper seat assembly aside. This step is also required for Repair Procedure 3.
5. Remove the roll pin from the shaft of the seat height lever using one of the following methods.
 - a. If the base has an access hole aligned with the roll pin (on the opposite side from the slot) remove the pin with a hammer and punch. See FIGURE 14.
 - b. If no access hole is present, attempt to grasp the roll pin using locking pliers and remove it by tapping the pliers with a hammer.

- c. If neither of the previous two methods works, drill a 3/8 inch diameter access hole in the spring cage, aligned with the roll pin; then remove the pin with a hammer and punch. See FIGURE 14 for location of access hole. **IMPORTANT:** Before drilling, mark the hole location using a center punch to prevent the drill bit from 'walking'. After drilling hole, remove all metal shavings to prevent them from damaging the seat mechanism.
6. Discard the old roll pin. A new longer pin is supplied in the kit.

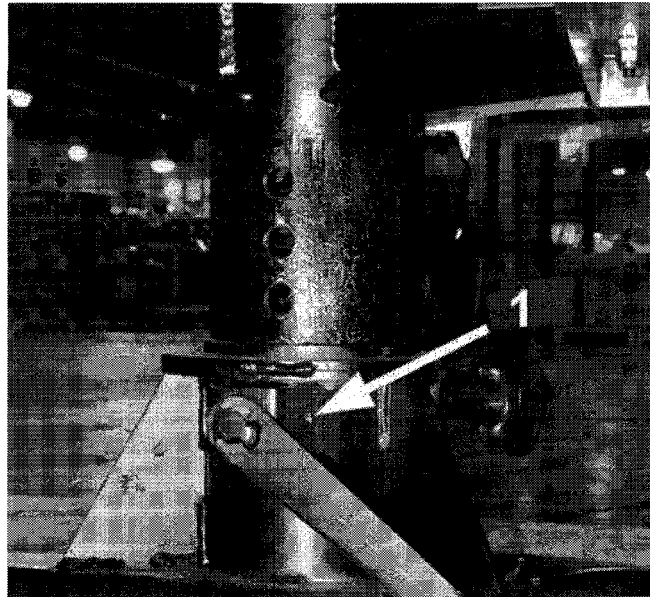

Figure 14. Roll Pin Access Hole

7. Remove the tension spring and the lever assembly from the seat base. See FIGURE 13. Retain the tension spring and discard the old lever assembly.
8. While holding the tension spring in place, insert the new seat height lever into position in the seat base, capturing the tension spring.

CAUTION: In the following step the new roll pin **MUST BE** installed **with the groove on top**.

9. Using locking pliers, compress the tension spring; then, use a hammer to install the new roll pin. See FIGURES 15 & 16. The roll pin is correctly installed when the following conditions are met:
 - a. The groove in the roll pin is facing up.
 - b. The pin must be driven far enough through the shaft so that the tension spring rests against the pin on both sides of the shaft.
 - c. The leading end of the pin must not contact the wall of the spring cage when the seat height lever is moved through its range.

- d. The pin must protrude at least 7/16 inch outside of the slotted surface when the seat height lever is in the down (engaged) position.
10. Apply grease to the roll pin and slot prior to operating seat height lever.

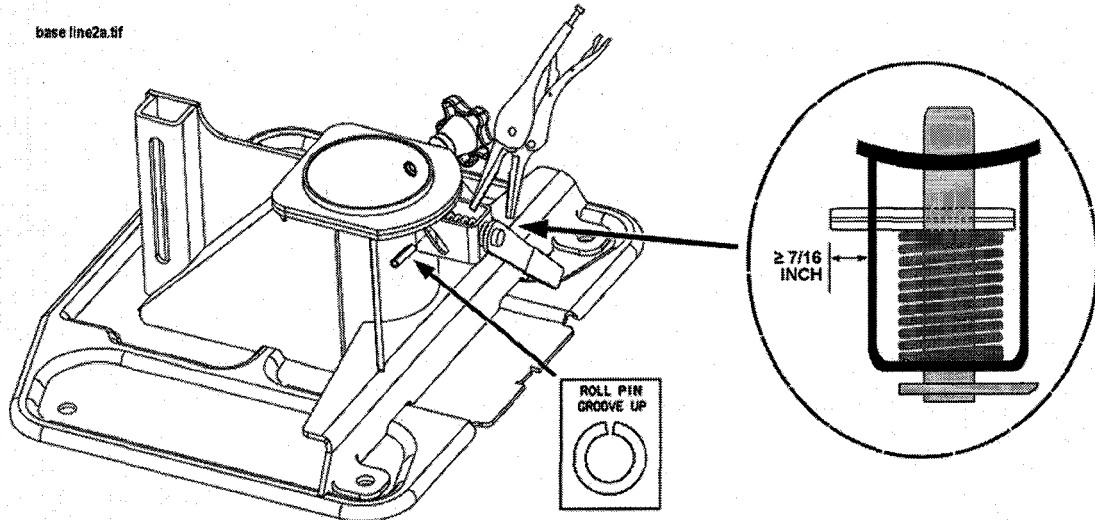

FIGURE 15.

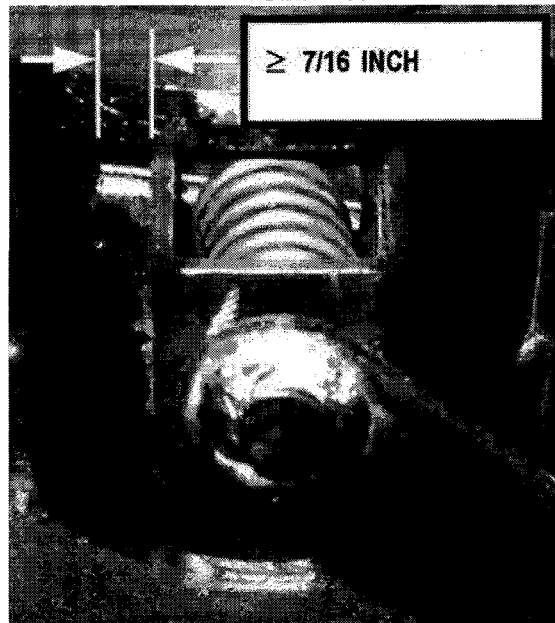

FIGURE 16.

NOTE: The following step is a two person operation. While one person lowers the seat assembly, the other person must guide the seat assembly to insure that the springs, cylinders, and up-stop mechanism are correctly aligned. See FIGURE 17.

11. Assemble the seat by lowering the seat assembly onto the lower seat base. Once the base components are correctly aligned, raise (disengage) the seat height lever

and push down on the seat. When the seat reaches its top position, release the lever to engage the seat height locking pin. Step 11 is not required if proceeding to complete Repair Procedure 3.



FIGURE 17.

12. Verify that the seat is in its top position (3 holes visible in seat base cylinder). See FIGURE 18. If the seat is equipped with an up-stop mechanism, install the limiting bolt and nut that were removed at the beginning of this procedure. The limiting bolt will prevent the seat from being raised beyond its top position. Do not over tighten the nut, or the seat will not move up and down. Step 12 is not required if proceeding to complete Repair Procedure 3.
13. Leaving the seat in its top position, connect the seat-to-floor tethers and adjust them to a tight condition. Step 13 is not required if proceeding to complete Repair Procedure 3.

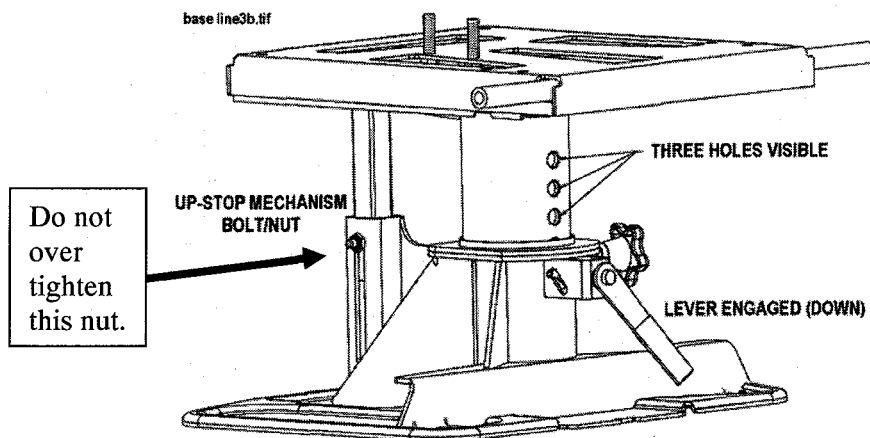

FIGURE 18.

End of Repair Procedure 2

Repair Procedure 3 – Supplemental Seat Height Spring and Spring Retainer – Manual Seats

1. Disconnect any seat-to-floor tethers by unbolting them from the seat. **DO NOT** unbolt the tethers from the vehicle floor. If continuing from Repair Procedure 2, this step should already be complete.
2. If seat is equipped with an up-stop mechanism, remove the limiting bolt and nut. See FIGURE 19. Retain this hardware for use during assembly. If continuing from Repair Procedure 2, this step should already be complete.
3. Loosen the seat height adjustment lock knob enough to allow seat height adjustment. If continuing from Repair Procedure 2, this step should already be complete.

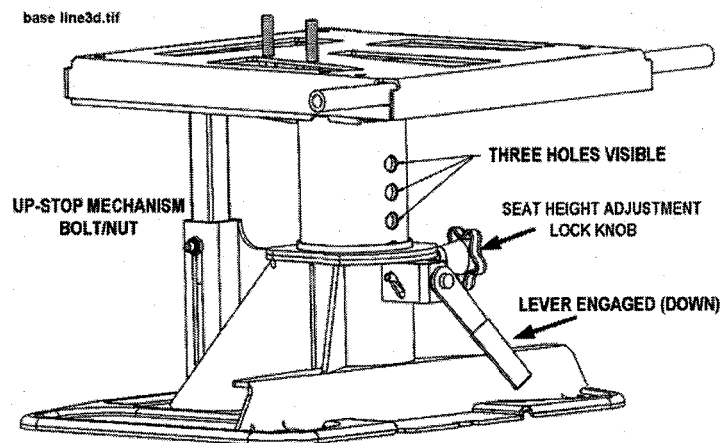

FIGURE 19.

4. With seat height lever raised to disengage, lift upper seat assembly off of lower base. If continuing from Repair Procedure 2, this step should already be complete.
5. Partially remove the cover from the bottom seat cushion to allow access to the top of the seat base frame. Unclip cover from seat frame as needed. See FIGURE 20.

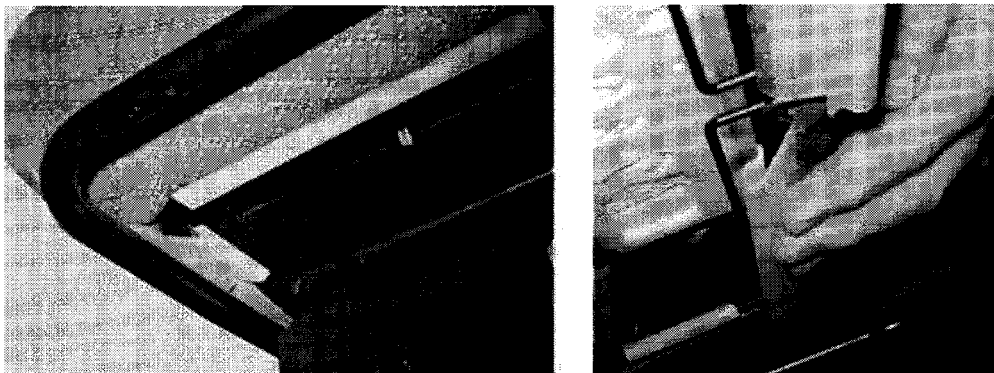
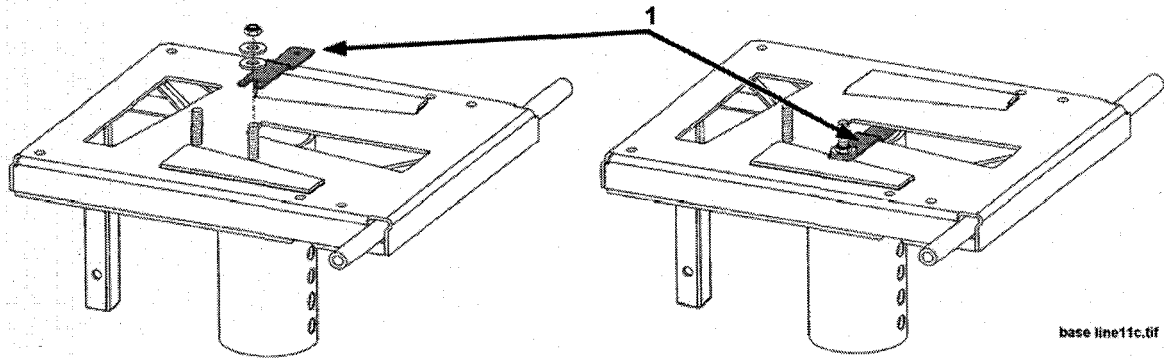

FIGURE 20.

6. Install spring retainer plate on frame of seat bottom as indicated in FIGURE 21.
7. Install supplemental seat height spring from kit inside of existing spring in seat base. See FIGURE 22.



1. SPRING RETAINER

FIGURE 21.

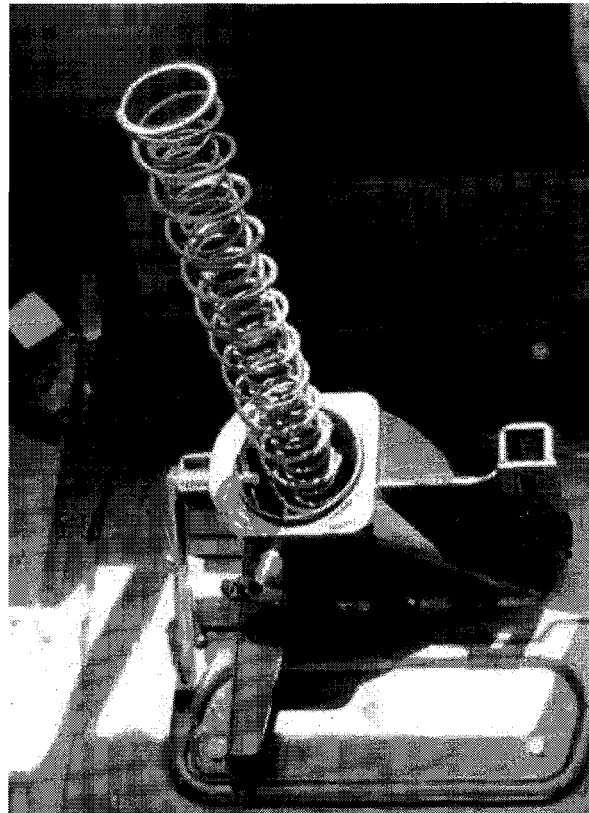

FIGURE 22.

NOTE: The following step is a two person operation. While one person lowers the seat assembly, the other person must guide the seat assembly to insure that the springs, cylinders, and up-stop mechanism are correctly aligned. See FIGURE 23.

8. Assemble the seat by lowering the seat assembly onto the lower seat base. Once the base components are correctly aligned, raise (disengage) the seat height lever and push down on the seat. When the seat reaches its top position, release the lever to engage the seat height locking pin. The lever will be in the down position.

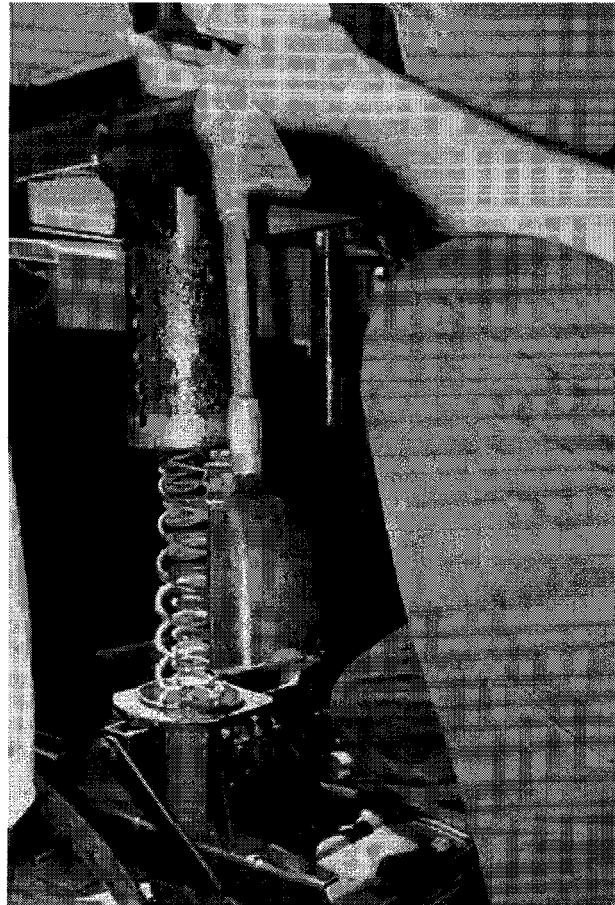

FIGURE 23.

NOTE: The tethers that limit seat height travel have not yet been installed. If the seat is NOT equipped with an up-stop mechanism, do not allow the seat to rise above its top position, as it could become disengaged from the lower seat base.

9. Verify that the seat is in its top position (3 holes visible in seat base cylinder). See FIGURE 24. If the seat is equipped with an up-stop mechanism, install the limiting bolt and nut that were removed at the beginning of this procedure. Do not over tighten the nut, or the seat will not move up and down. The limiting bolt will prevent the seat from being raised beyond its top position.

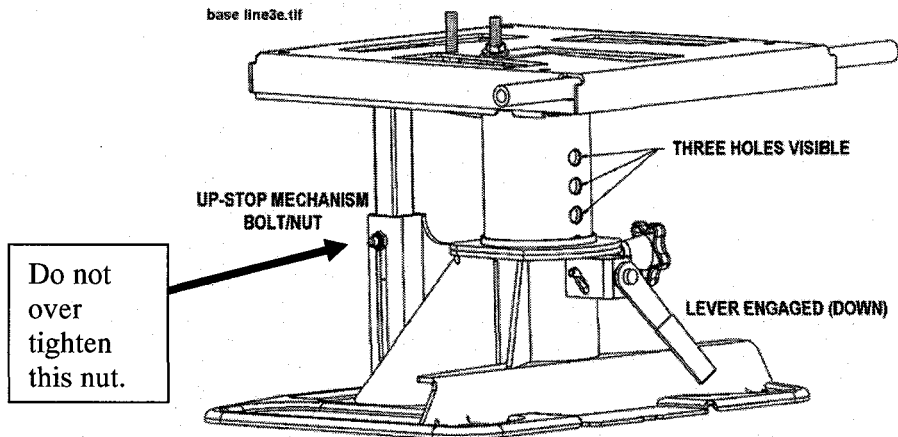
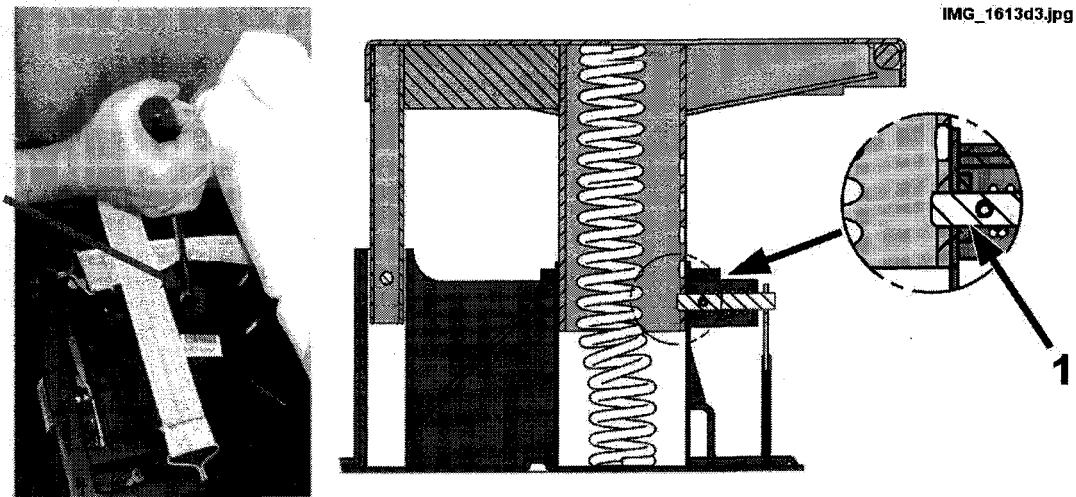

FIGURE 24.

10. Through the opening at the top of the seat base cylinder, use a screwdriver to position the seat height springs away from the seat height locking pin. The springs should be adjusted so that they arc away from the locking pin (push over with screwdriver as shown on the left in FIGURE 25, push toward front of bus). This step creates the clearance needed to prevent interference between the seat height locking pin and the springs.



1. SEAT HEIGHT LOCKING PIN

FIGURE 25.

11. Install cover on bottom seat cushion. See **FIGURE 20**.
12. With the seat in its top position, adjust the seat-to-floor tethers to a tight condition. See **FIGURE 24**. If continuing to Repair Procedure 4, this step is not necessary

End of Repair Procedure 3

Inspection for Seat Height Travel Limit (Prior To Repair Procedure 4)

Before Completing Repair 4, inspect the seat in order to determine if it has an up-stop mechanism. If your bus has this mechanism, Repair Procedure 4 will not have to be completed. See FIGURE 26.



Up-stop
mechanism
(Vertical slot
with bolt and
nut)

FIGURE 26.

End Inspection for Repair Procedure 4

Repair Procedure 4 - National Bus Seat Service Letter – Installation of New Seat Travel Tether

This kit is required on all manual seats that **do not** have a factory installed up-stop mechanism.

1. Loosen the seat height adjustment lock knob enough to allow seat height adjustment. See FIGURE 27. If continuing from Repair Procedure 2 and 3, this step should already be complete.
2. Raise the seat to its top position by lifting the seat height lever and lifting the seat. With the seat in its top position, three holes are visible on the rear of the seat base cylinder.
3. Ensure the locking pin is in position in the hole of the top adjustment hole.

NOTE: If seat-to-floor tethers prevent the seat from being raised to this position, loosen the tethers enough to allow the seat to reach its top position, then retighten both seat to floor tethers.

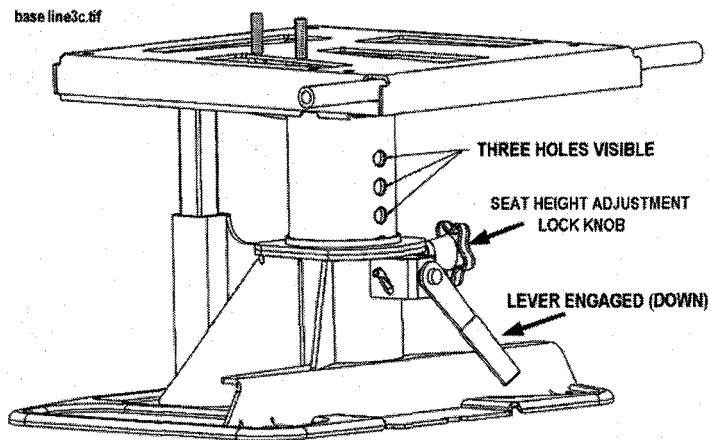

FIGURE 27.

NOTE: Use a center punch prior to drilling holes, to prevent drill bit from 'walking'.

4. Using a center punch, mark the location of the top hole on the front rail of the seat frame, as indicated in FIGURE 28.
5. Using a 3/8 inch bit, drill the top hole.

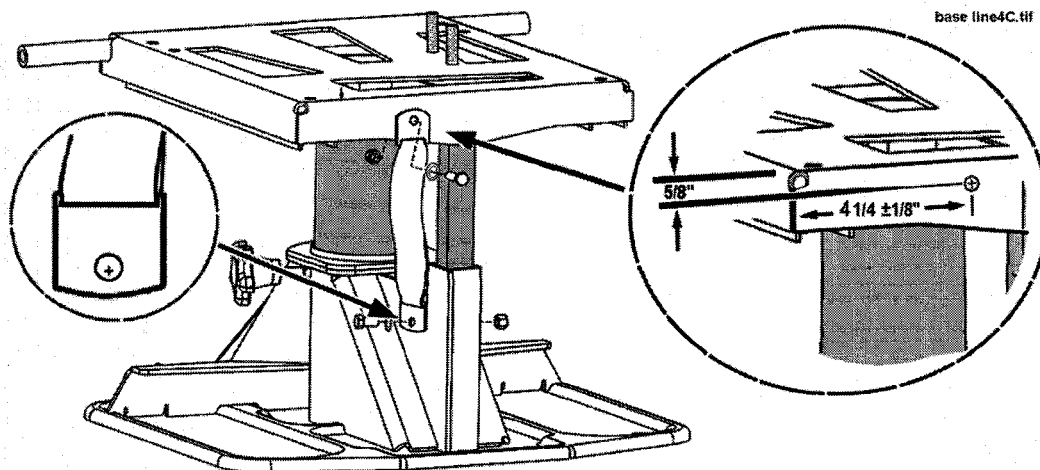

FIGURE 28.

6. Secure the top of the seat height travel tether using a bolt, washer, and nut provided in the kit.

NOTE: In the following step insure that the bottom hole is located so that it DOES NOT interfere with the seat base mechanism in any way. The bolt is a smaller diameter than the hole in the tether end plate, so the drilled hole must be offset slightly towards the end of the tether to insure that the tether is stretched tight when installed. See FIGURE 28.

7. Pull the tether tight and use the center punch to mark the location of the bottom hole. See FIGURE 28.
8. Using a 3/8 inch bit, drill the bottom hole.
9. Secure the bottom of the tether with the bolt, washer, and nut provided in the kit.
10. Leaving the seat in its top position, adjust the seat-to-floor tethers to a tight condition.

End of Repair Procedure 4

Please affix the Seat Adjustment Warning Label if not already on the seat. This should be requested when parts are ordered if it is not already in place on your seat.

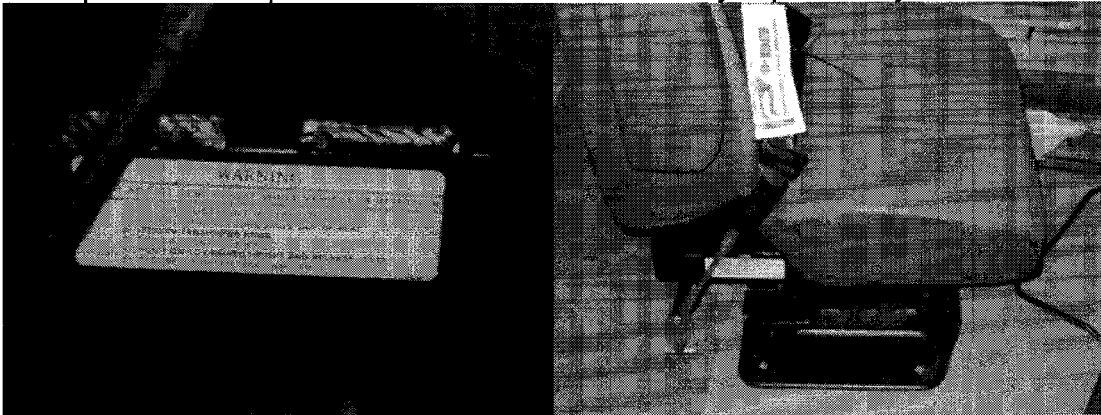

End of Repair Procedures

LABOR

Labor Code	Description	Time (hours)
A40-06512-01	Install retractor cover on seatbelt (Repair 1)	0.4
A40-06512-02	Install Lever Replacement (Repair 2)	0.3
A40-06512-03	Install Supplemental Spring and Retainer (Repair 3)	0.2
A40-06512-04	Inspect for Travel Stop (Inspection for Repair 4)	0.1
A40-06512-05	Install Seat Travel Tether (Repair 4)	0.1

CAMPAIGN IDENTIFICATION LABEL

*Each vehicle corrected in accordance with this campaign **must be** marked with a S00109 Campaign Identification Label.*

Complete the label and attach on a clean surface next to the vehicle identification number (VIN) plate.

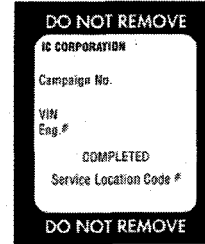

This label has been shipped with your letter. Please complete and apply this label after inspection and/or repair.

IMPORTANT

In the event you no longer own the vehicle described, please fill in the requested information on the enclosed postage-prepaid card and return it to us. This information will allow us to notify the correct owner.

IC CORPORATION