



RECEIVED

2006 AUG 11 A 9:49

IC Corporation

OFFICE OF THE ATTORNEY GENERAL

06V-283

751 South Harkrider, Conway, Ar 72302

NON-COMPLIANCE RECALL 06507

September, 2006

Dear IC Corporation Customer:

This notice is sent to you in accordance with the requirements of the National Traffic and Motor Vehicle Safety Act. IC Corporation has decided that certain BE and CE school buses built between 8/3/2005 and 5/1/2006 may fail to conform to Federal Motor Vehicle Safety Standard No.210, "Seat Belt Assembly Anchorages". The vehicle identified on the enclosed green card fits this description and our records show that you own this vehicle. Federal regulations require that any vehicle lessor receiving this recall notice must forward a copy of this notice to the lessee within ten days.

REASON FOR THIS RECALL

The configuration of the mounting bracket for the 39 inch track mounted CE White child safety seat does not provide sufficient strength to meet the requirements of FMVSS 210 if seat belts are attached.

RISK TO MOTOR VEHICLE SAFETY

In the event of a vehicle crash, this mounting configuration, with seat belts attached to the seats, may result in a lack of structural integrity, possibly resulting in an injury or death to the belted occupants.

ACTIONS YOU SHOULD TAKE

1. **Our records show that you are the owner** of the vehicle identified on the enclosed card. **If you are not the owner**, please read paragraph number 6.
2. If you would like your IC dealer to make this inspection and repair for you at no cost, **please contact your local IC dealer**. To have your vehicle repaired, provide your dealer with your green recall card and schedule an appointment.
3. If you prefer to inspect and repair the vehicle yourself, the repair instructions are outlined in the "Inspection Procedure" and "Repair Procedure" sections below.

To order parts, fill out and return the enclosed green recall card with box # 8 checked and our Compliance Department will have the parts shipped directly to you at no charge. Please verify that your shipping address is correct. A Post Office Box (P.O. Box) number for shipping is not acceptable. We must have a street or road address. You may also obtain these parts by faxing a request to 1-501-505-2433 or emailing to shawn.finkbeiner@ic-corp.com. If you have multiple VINs that fall within this recall, a fax is the preferred method. The last eight characters of the VIN of each unit to be repaired must be included.

4. IC dealers will have instructions to make the repair by **09/01/2006**. The repair will be performed without charge to you and will take approximately 1.4 hours per seat. Have your dealer verify and correct your address, if necessary.
5. If the **vehicle will not be corrected or cannot be corrected**, please mark on the enclosed card under "CHECK ONE" the box which best describes why the vehicle will not be repaired, and return the postage-prepaid card to us.
6. **In the event you do not own the vehicle** described on the card, please complete the card, fill in the new customer name and address if known, and return it to us. This information will allow us to update our records so we can contact the new owner and you will not be contacted again regarding this recall.

Any correspondence must be addressed to IC Corporation, PO Box 6000, Conway, Arkansas, 72033, Attn: Compliance Department. If you need to contact IC Corporation, please email Shawn Finkbeiner at shawn.finkbeiner@ic-corp.com.

RECALL CLAIMS

For Repairs Performed By Customer or Non-Authorized IC Dealers

To assist in processing the recall, it is important that you provide an invoice with the following information.

VIN # (or List of VINs repaired)
Recall Campaign #06507
SUBJECT (CE White Seats)
Facilities Repair Labor Rate
Labor Operation Number
Your Tax ID Number
Hours to Repair

All correspondence must be returned to IC Corporation, PO Box 6000, Conway, Arkansas, 72033, Attn: Compliance Department.

IF YOU NEED ASSISTANCE

If you take your vehicle to your dealer on a mutually agreed upon service date, and the dealer does not remedy this condition without charge on that date or within five days, you can obtain assistance by following the procedure described in the Owner Assistance Guide section in your Owner's Manual or by calling toll free 1-800-448-7825.

You may also wish to submit a complaint to the Administrator, National Highway Traffic Safety Administration, 400 Seventh Street, S.W., Washington, D.C., 20590, or call the toll-free Vehicle Safety Hot-Line at 1-888-327-4236 (TTY: 1-800-424-9153); or go to <http://www.safercar.gov> if your IC Dealer fails to repair or is unable to remedy this condition without charge or within a reasonable time.

We request your prompt attention to the correction of this defect and apologize for any inconvenience this may cause you.

PARTS INFORMATION

Kit Part Number	Description	Contains
8900186R91	KIT, FIELD FIX CE WHITE 39 IN TRACK SEATS LH (left side)	2592744C1-1ea: Kit, Legs LH
		435054001-12 ea: Fitting, Track Seat Kinedyne
		452510001-12 ea: Fitting, Track Seat Q'Straint
		22264R1-16 ea: Washer, Flat
		2592743C1-1ea: Manual, Inst
8900187R91	KIT, FIELD FIX CE WHITE 39 IN TRACK SEATS RH (right side)	2592745C1-1ea: Kit, Legs RH
		435054001-12 ea: Fitting, Track Seat Kinedyne
		452510001-12 ea: Fitting, Track Seat Q'Straint
		22264R1-16 ea: Washer, Flat
		2592743C1-1ea: Manual, Inst



WARNING:

INVISIBLE ULTRAVIOLET AND INFRARED RAYS EMITTED IN WELDING CAN INJURE UNPROTECTED EYES AND SKIN. PROTECTION SUCH AS WELDER'S HELMET AND DARK COLORED FILTER LENSES OF THE PROPER DENSITY MUST BE USED. GTAW OR TIG WELDING WILL PRODUCE INTENSE RADIATION, THEREFORE, FILTER PLATE LENSES OF THE DEEPEST SHADE PROVIDING ADEQUATE VISIBILITY ARE RECOMMENDED. IT IS STRONGLY RECOMMENDED THAT PERSONS WORKING IN THE WELD AREA WEAR FLASH SAFETY GOGGLES. ALSO WEAR PROTECTIVE CLOTHING.



WARNING:

TO AVOID SERIOUS EYE INJURY, ALWAYS WEAR SAFE EYE PROTECTION WHEN YOU PERFORM VEHICLE MAINTENANCE OR SERVICE.



WARNING:

TO AVOID PROPERTY DAMAGE, PERSONAL INJURY, OR DEATH WHEN SERVICING THE VEHICLE, PARK ON A FLAT LEVEL SURFACE, SET THE PARKING BRAKE, SHUT THE ENGINE OFF AND CHOCK THE WHEELS.

INSPECTION PROCEDURE

Please inspect each bus to determine if this repair is necessary. The affected seats will have a mixture of leg types. See photos below. If there are two bolts behind both rear leg posts (toward the rear of the bus as shown in photo 2 below with 4 mounting bolts) the seat does not need to be repaired. If there is only one bolt behind either leg post (toward the rear of the bus as shown in the photo 1 below with 3 mounting bolts), then the seat needs to be repaired.

Photo 1



Original Outside leg –
3 mounting bolts

Photo 2

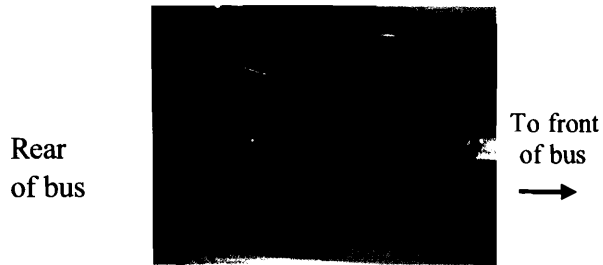

Original Aisle leg –
4 mounting bolts

REPAIR PROCEDURE

PLEASE read all instructions prior to starting the repair process.

Tags on the following figures refer to the following items:

ITEM	DESCRIPTION
1	Leg, BOL Track 10.75
2	Leg, BOL Track Offset
3	Brkt, front corner mount boomerang
4	Screw, 7/15-14X 1.25 Hex Head, Grade 5
5	Washer, 7/16 Flat, USS Zinc
6	Nut, 7/16-14 Nylock Zinc Plated
7	Nut, 1/4 -20 Nylock Zinc Plated
8	Screw, 1/4 -20 X1.75 Hex Cap Gr 5 Zinc
9	Screw, 1/4 -20 X1 Hex Head Gr 5
10	Washer, 1/4 Flat Zinc
11	Fitting, Track Kinedyne
12	Fitting, Track Q-Strait

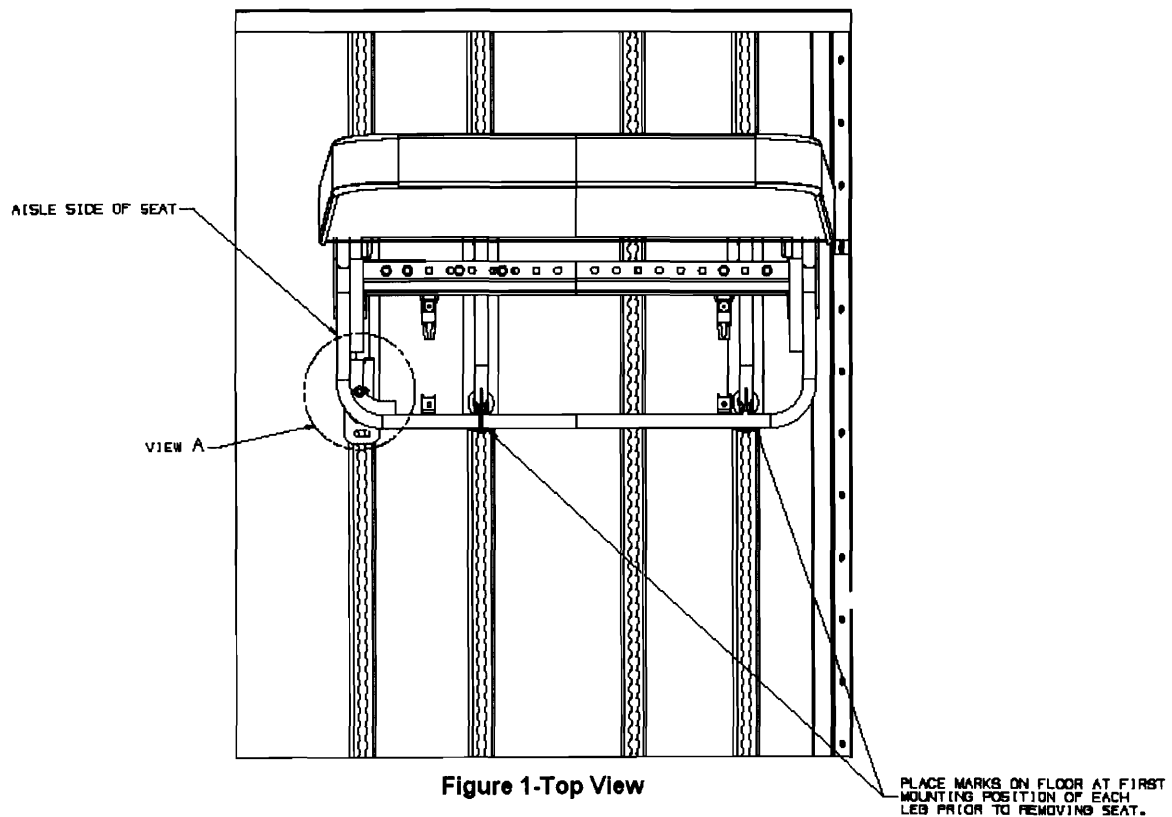
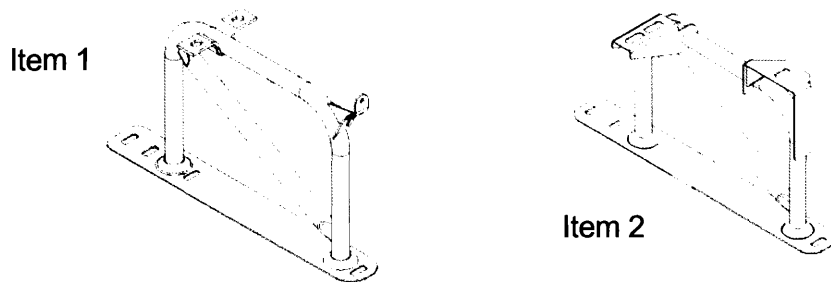

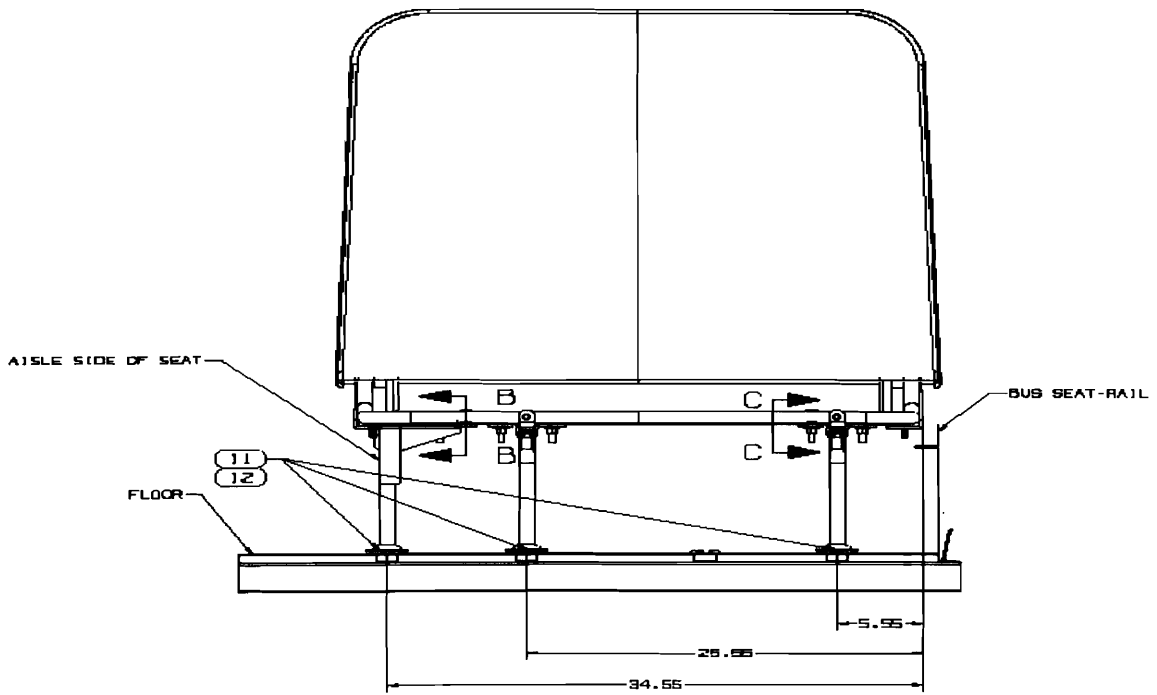

Figure 2 - Front View

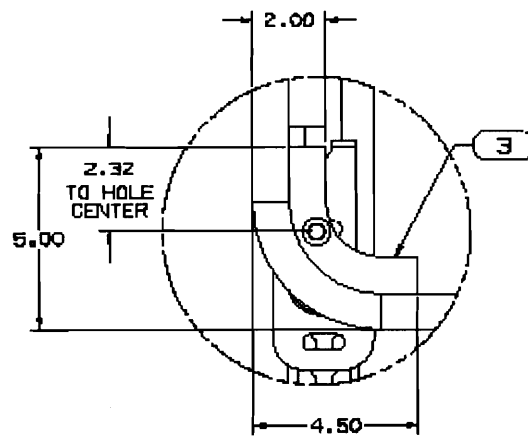

Figure 3-View A

SCALE 1:2

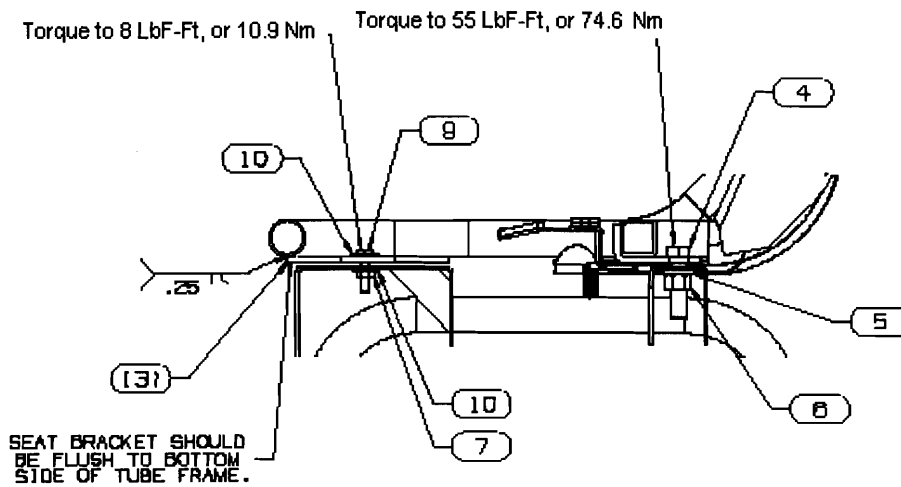

Figure 4-Section B-B

SCALE 1:2

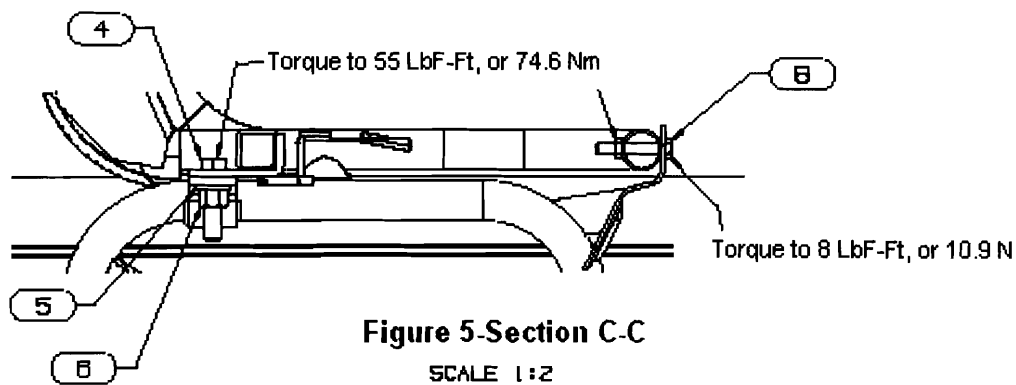

Figure 5-Section C-C

SCALE 1:2

1. Using a pencil (or any removable marking utensil or technique) mark the location of the seat. Place a mark on the floor next to the front track mounting position of each leg. See Figure 1, Top View.
2. Remove track hardware from seat legs and remove seat from vehicle.
3. Remove bottom seat cushion from frame by rotating the seat two clips (located underneath the rear of the seat bottom) 90 degrees in either direction.
4. After rotating the seat clips, grasp the rear side of the seat and pull up.
5. Position the aisle side leg bracket. This is item 3 in Figure 3. Ensure that the bracket is flush with the bottom of the seat frame. Tack weld bracket into place.

6. Verify dimensional locations of the bracket. After verifying that the bracket is located correctly, complete the welding process as shown in section B-B. The weld should consist of a .25" bead along the outside edge of the bracket and seat frame. A weld blanket should be used to protect the seat back and seat belts.
7. Grind welds smooth to ensure the removal of any sharp edges created by adding the bracket.
8. Remove existing seat legs from the seat frame. These also may be removed prior to welding if desired.
9. Prime and paint welded area. Prime and paint surrounding areas as needed.
10. Install new legs provided with the kit. See Figure 1, Section B-B, and section C-C.
11. Reinstall the bottom seat cushion onto the seat frame.
12. Reinstall the seat in the location marked in step 1. Use item 11 with Kinedyne or Sure-Lok track (torque to 25-30 LbF-Ft, 34.9-47.6 Nm). Use item 12 with Q-Straint track (torque to 35 LbF-Ft, 47.4 Nm). Pictures below show the difference between the Kinedyne and Q'Straint type tracks.

Kinedyne or
Sure Lock
Track will have
a smooth
surface on the
flanges of the
track



Q'Straint track
will have a rib
on both
flanges of the
track

End of Repair Procedure

LABOR

Labor Code	Description	Time (hours)
A40-06507-01	Repair time per seat	1.4

CAMPAIGN IDENTIFICATION LABEL

*Each vehicle corrected in accordance with this campaign **must be** marked with a S00109 Campaign Identification Label.*

Complete the label and attach on a clean surface next to the vehicle identification number (VIN) plate.



This label has been shipped with your letter. Please complete and apply this label after inspection and/or repair.

IMPORTANT

In the event you no longer own the vehicle described, please fill in the requested information on the enclosed postage-prepaid card and return it to us. This information will allow us to notify the correct owner.

IC CORPORATION