



IC Corporation

751 South Harkrider, Conway, Ar 72302

RECEIVED

2006 MAY 12 P 12:51

SAFETY RECALL 06503

**SAFETY RECALL 06503**

**May 20, 2006**

Dear IC Corporation Customer:

This notice is sent to you in accordance with the requirements of the National Traffic and Motor Vehicle Safety Act. IC Corporation has decided that a defect which relates to motor vehicle safety exists in certain IC (2007 Model year), CE (2006 & 2007 Model Years), FE (2006 Model Year), and RE (2006 Model Year) Bus models built between 6/12/2005 and 3/29/2006 with Ricon wheelchair lifts. The vehicle identified on the enclosed green card fits this description and our records show that you own this vehicle. Federal regulations require that any vehicle lessor receiving this recall notice must forward a copy of this notice to the lessee within ten days.

**REASON FOR THIS RECALL**

The vertical lift arms on Ricon wheelchair lift models 1200, 2000, and 5500, built between June 12, 2005 and July 1, 2005, and with specific serial numbers, may have a defective weld.

**RISK TO MOTOR VEHICLE SAFETY**

The defective weld may result in a crack in the vertical lift arm, thereby causing the wheelchair lift to not deploy or to not stow properly. In the event this occurs during passenger loading or unloading, it may not be possible to close the lift door, which would prevent the interlock from allowing the vehicle to move or the ability to load or unload passengers with disabilities from the vehicle. This may result in injury or death.

**ACTIONS YOU SHOULD TAKE**

1. Our records show that you are the owner of the vehicle identified on the enclosed card. **If you are not the owner**, please read paragraph number 11.
2. To inspect the vehicle yourself, look up your Ricon wheelchair lift serial number on the list found in the **Inspection** section below. See Figure 1 for location of serial number decal.

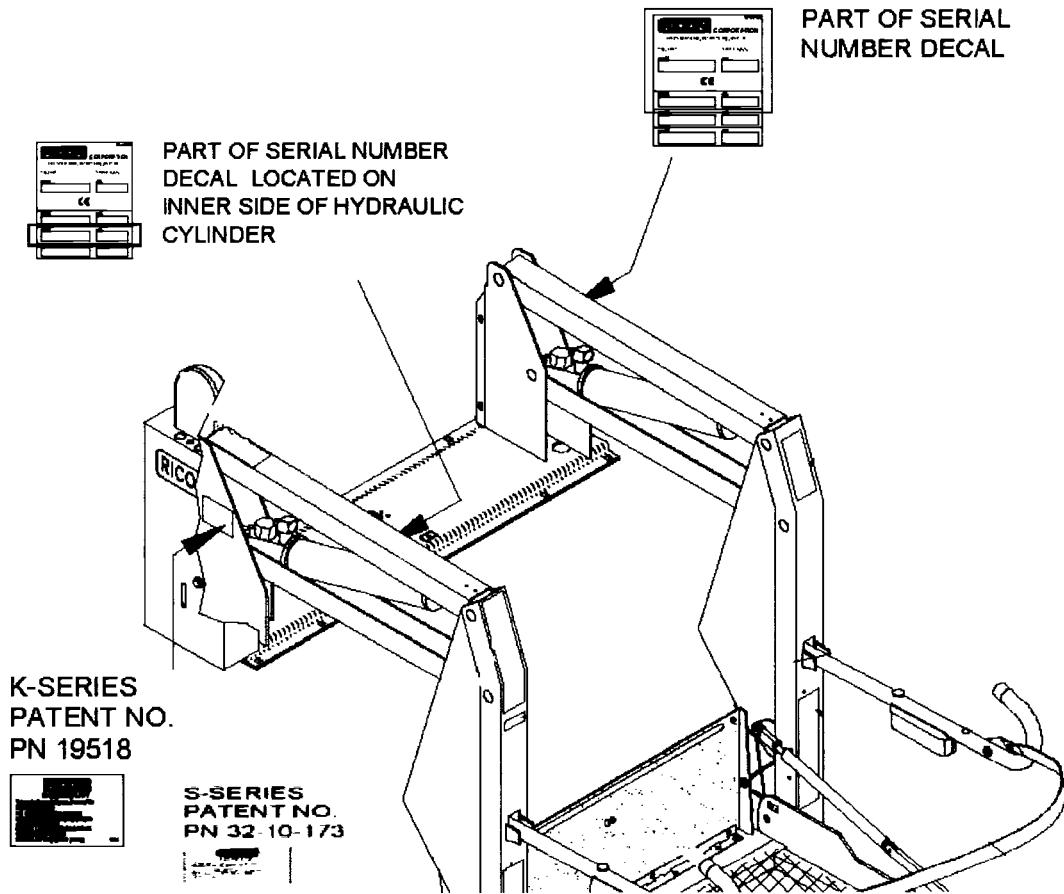

Figure 1

3. If you would like your IC dealer to make this inspection for you at no cost, please contact your local IC dealer.
4. If the serial number for your wheelchair lift is not found on the list in the **Inspection** section, then fill out the green card by checking box **#1 Vehicle Inspected – no corrections necessary**, and drop it in the mail.
5. If your wheelchair lift is a Ricon model 1200, 2000, or 5500, and the lift serial number is on the list in the **Inspection** section, you may contact your local IC dealer to determine if they are also an authorized Ricon dealer.
6. If you have determined that your local IC dealer is an authorized Ricon dealer, then provide your IC dealer with your green recall card and schedule an appointment for repair. This repair will take approximately one hour.
7. If you determine that your local IC dealer is not an authorized Ricon Dealer, you may visit the Ricon website at <http://www.riconcorp.com/> and use the Ricon dealer locator. Do not use the VMI dealer link on the Ricon website, as they are not

authorized to make this repair. Alternately, you may contact Ricon directly at (800) 322-2884, then dial

Billy McCoy	extension 3323
Ericka Acevedo	extension 3034
Luis Ballote	extension 3326

8. No parts will be supplied by IC Corporation for this recall. Ricon will supply replacement vertical lift arms as necessary to an authorized IC/Ricon dealer, or through an authorized Ricon dealer or representative.

9. IC dealers will be notified of this campaign by 5/12/2006. The repair will be performed without charge to you. Have your dealer verify and correct your address, if necessary.

10. If the vehicle cannot be repaired, please mark on the enclosed card under "CHECK ONE" the box which best describes why the vehicle cannot be repaired, and return the postage-prepaid card to us.

11. In the event you do not own the vehicle described on the card, please complete the card, fill in the new customer name and address if known, and return it to us. This information will allow us to update our records so we can contact the new owner and you will not be contacted again regarding this recall.

12. Any correspondence must be addressed to IC Corporation, PO Box 6000, Conway, Arkansas, 72033, Attn: Compliance Department. If you need to contact IC Corporation, please email Kathy Anders at [Kathy.anders@ic-corp.com](mailto:Kathy.anders@ic-corp.com).

### **IF YOU NEED ASSISTANCE**

If you take your vehicle to your dealer on a mutually agreed upon service date, and the dealer does not remedy this condition without charge on that date or within five days, you can obtain assistance by following the procedure described in the Owner Assistance Guide section in your Owner's Manual or by calling toll free 1-800-448-7825.

You may also wish to submit a complaint to the Administrator, National Highway Traffic Safety Administration, 400 Seventh Street, S.W., Washington, D.C., 20590, or call the toll-free Vehicle Safety Hot-Line at 1-888-327-4236 (TTY: 1-800-424-9153); or go to <http://www.safercar.gov> if your IC Dealer/Ricon Dealer or Ricon dealer or representative fails to repair or is unable to remedy this condition without charge or within a reasonable time.

We request your prompt attention to the correction of this defect and apologize for any inconvenience this may cause you.

## PARTS INFORMATION

Parts will be supplied by an authorized Ricon Dealer. This repair will be performed by an authorized Ricon Dealer or representative. International will not stock or ship parts.

## INSPECTION

Determine the serial number of your Ricon wheelchair lift. Look it up on the list below, and then follow the instructions in the **Actions You Should Take** section above. If your serial number is on the list, the repair must be made by an authorized IC/Ricon dealer or an authorized Ricon dealer or representative.



**WARNING:**

**TO PREVENT SERIOUS EYE INJURY, ALWAYS WEAR SAFE EYE PROTECTION WHEN YOU PERFORM VEHICLE MAINTENANCE OR SERVICE.**



**WARNING:**

**TO AVOID PROPERTY DAMAGE, PERSONAL INJURY, OR DEATH WHEN SERVICING THE VEHICLE, PARK ON A FLAT LEVEL SURFACE, SET THE PARKING BRAKE, SHUT THE ENGINE OFF AND CHOCK THE WHEELS.**

<b>Ricon Wheelchair Lift Serial Numbers</b>					
<b>Lift Series</b>	<b>S/N</b>	<b>Item Code</b>	<b>Lift Series</b>	<b>S/N</b>	<b>Item Code</b>
K	186305	K5510-F1020100A	S	187476	S5505-F1020000A
S	186673	S5503-F1020000A	S	187478	S5505-F1020000A
S	186871	S5505-F1020000A	S	187536	S5505-F1020000A
S	187054	S5505-F1020000A	S	187537	S5505-F1020000A
S	187055	S5505-F1020000A	S	187538	S5505-F1020000A
S	187140	S5505-F1020100A	S	187539	S5505-F1020000A
S	187141	S5505-F1020100A	S	187540	S5505-F1020000A
S	187142	S5505-F1020100A	S	187543	S5505-F1020000A
S	187143	S5505-F1020100A	S	187544	S5505-F1020000A
S	187145	S5505-F1020100A	S	187545	S5505-F1020000A
S	187146	S5505-F1020100A	S	187546	S5505-F1020000A
S	187147	S5505-F1020100A	S	187547	S5505-F1020000A
S	187169	S5505-F1020000A	S	187548	S5505-F1020000A
S	187170	S5505-F1020000A	S	187549	S5505-F1020000A
S	187171	S5505-F1020000A	S	187550	S5505-F1020000A
S	187230	S5503-F1020000A	S	187551	S5505-F1020000A
S	187231	S5503-F1020000A	S	187552	S5505-F1020000A
S	187296	S5503-F1020000A	S	187553	S5505-F1020000A

S	187297	S5503-F1020000A	S	187554	S5505-F1020000A
S	187299	S5503-F1020000A	S	187593	S5505-F1020000A
S	187346	S5505-F1020100A	S	187594	S5505-F1020000A
S	187348	S5505-F1020100A	K	187672	K5510-F1020000A
S	187351	S5505-F1020100A	S	188129	S5505-F1020000A
S	187470	S5505-F1020000A	S	188139	S5505-F1020000A
S	187472	S5505-F1020000A	S	188140	S5505-F1020000A
S	187473	S5505-F1020000A	S	188141	S5505-F1020000A
S	187474	S5505-F1020000A	S	188218	S5503-F1020000A
S	187475	S5505-F1020000A	S	188219	S5503-F1020000A

**End of Inspection Procedure**

**CAMPAIGN IDENTIFICATION LABEL**

*Each vehicle corrected in accordance with this campaign **must be** marked with a S00109 Campaign Identification Label.*

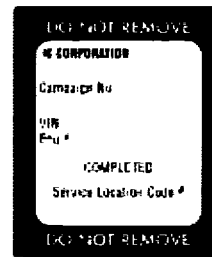

Complete the label and attach on a clean surface next to the vehicle identification number (VIN) plate.

This label has been shipped with your letter. Please complete and apply this label if your wheelchair lift serial number is not on the list.

**IMPORTANT**

In the event you no longer own the vehicle described, please fill in the requested information on the enclosed postage-prepaid card and return it to us. This information will allow us to notify the correct owner.

**IC CORPORATION**