

# VEHICLE RECALL

G-06512  
February, 2007

## SUBJECT: RECALL (U.S., EXPORT)

National Seat ABTS (All Belts To Seat) Driver's Seat on certain BE, CE, FE, and RE school and commercial buses built between October 11, 2005 and October 31, 2006 with property codes 0048VUK, 0048VUJ, 0048VUP, and 0048VUR.

## DEFECT DESCRIPTION

There are four issues that may exist for the National Seat ABTS (All Belts To Seat) driver's seat that this recall will remedy.

- For Air and Manually Adjustable ABTS Seats:
  - The driver's seatbelt retractor may not work properly if the seat back is pushed against a barrier or other objects behind the driver's seat.
- For Manually Adjustable ABTS Seats:
  - The driver's seat may be pulled upward past the last seat adjustment position.
  - The seat and adjustment handle may pinch the driver's hand when the seat is adjusted while the driver is sitting on it.
  - The driver's seat may be difficult to raise to a higher position due to its weight.

## MODELS INVOLVED

- BE, CE, FE, RE School and Commercial Buses
- Manufactured October 11, 2005 through October 31, 2006
- Property Codes 0048VUK, 0048VUJ, 0048VUP, and 0048VUR

## PARTS INFORMATION

Kit Part Number	Description
8900192R91	National Drivers Seat – Seatbelt Retractor Cover Kit (Air & Manual Seats) – for repair 1
8900197R91	National Drivers Seat - Manual Seat Kit (Lever, Spring, Tether) – for repairs 2, 3, & 4

RECEIVED  
2007 FEB 26 A 11:51  
OFFICE OF THE SECRETARY  
OF THE DEPARTMENT OF  
TRANSPORTATION

## **REPAIR PROCEDURES**



***WARNING:***

***TO AVOID SERIOUS EYE INJURY, ALWAYS WEAR SAFE EYE PROTECTION WHEN YOU PERFORM VEHICLE MAINTENANCE OR SERVICE.***



***WARNING:***

***TO AVOID PROPERTY DAMAGE, PERSONAL INJURY, OR DEATH WHEN SERVICING THE VEHICLE, PARK ON A FLAT LEVEL SURFACE, SET THE PARKING BRAKE, SHUT THE ENGINE OFF AND CHOCK THE WHEELS.***



***WARNING:***

***TO AVOID PROPERTY DAMAGE, PERSONAL INJURY, OR DEATH WHEN SERVICING THE VEHICLE, THE FOLLOWING PROCEDURE MUST BE PERFORMED WITH THE LOWER SEAT BASE MOUNTED FIRMLY TO THE VEHICLE FLOOR. DUE TO THE SPRING FORCES PRESENT, THESE PROCEDURES MUST NOT BE PERFORMED WITH THE LOWER SEAT BASE REMOVED FROM THE VEHICLE.***

**PLEASE** read all warnings, inspection, and repair instructions prior to starting the repair process. There are 4 separate repair and 1 inspection procedure. The setup and reassembly instructions for some procedures are the same. Some of these steps may be eliminated when moving from 1 repair to the next. Comments have been added when steps are affected by duplication in multiple procedures.

- 1) Repair 1 - Seatbelt Retractor
- 2) Repair 2 - Height Adjustment Lever
- 3) Repair 3 - Supplemental Spring
- 4) Inspection 1 – Inspect prior to Repair 4
- 5) Repair 4 - Non-adjustable Tether

**NOTE:** During the manufacturing process on manual seats without an up-stop mechanism, a plastic tie-strap is used to keep the seat height springs compressed (See FIGURE 1). Once the seat is assembled, this tie-strap must be removed to allow adjustment of the seat height. Before performing the following procedures, inspect the seat being modified and verify that the tie-strap has been removed. If necessary, remove the tie-strap.

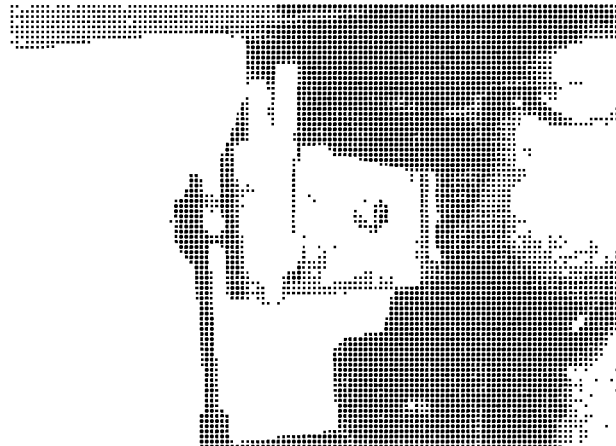

FIGURE 1.

### Repair Procedure 1 – Seatbelt Retractor – All seats

1. Arrange the steering wheel and seat to allow access to rear of upper seat back, on driver's seat (seat should be in forward and upright position).
2. Remove any items stored behind the driver's seat.
3. Remove inside seat arm.
  - a. Access the armrest tube underneath the foam and seat cover, as shown in FIGURE 2.

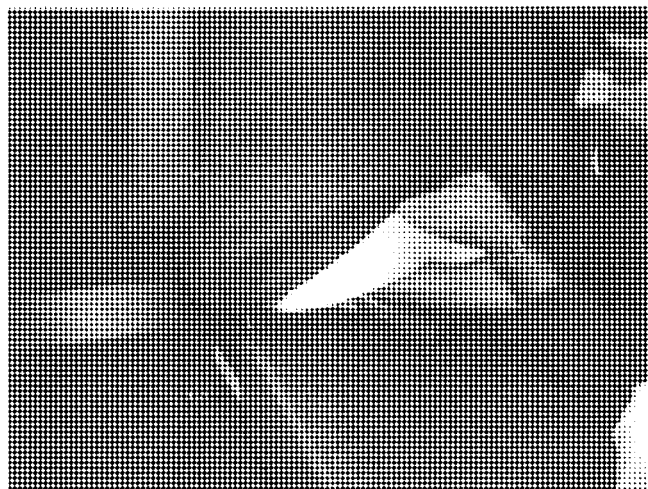

FIGURE 2.

- b. Locate the button on the armrest by inserting the screwdriver under the seat cover and foam, and into the middle of the armrest tube. See FIGURE 3. (Arm rest is shown already removed in FIGURE 3.)



FIGURE 3.

- c. Twist the screwdriver to depress the retaining button located in the arm rest tube. See FIGURE 4.

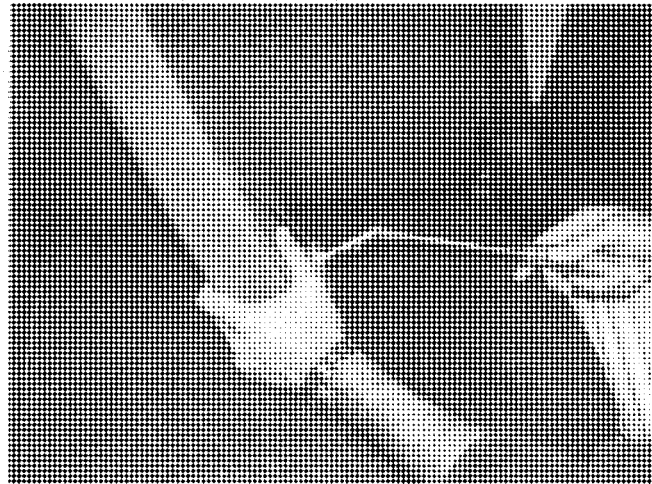

FIGURE 4.

4. Partially remove cover from upper seat back.
  - a. Front flap of cover is clipped to back flap of cover at bottom of seat back. The clip piece attached to the front flap must be pulled forward (rotated) to disconnect it from the clip piece attached to the back flap. See FIGURE 5.
  - b. Starting at the bottom, roll the cover up one or two rolls; then, grasping the rolled material, slip the cover upward until the upper left corner of the seat back is exposed. See FIGURES 6 & 7.

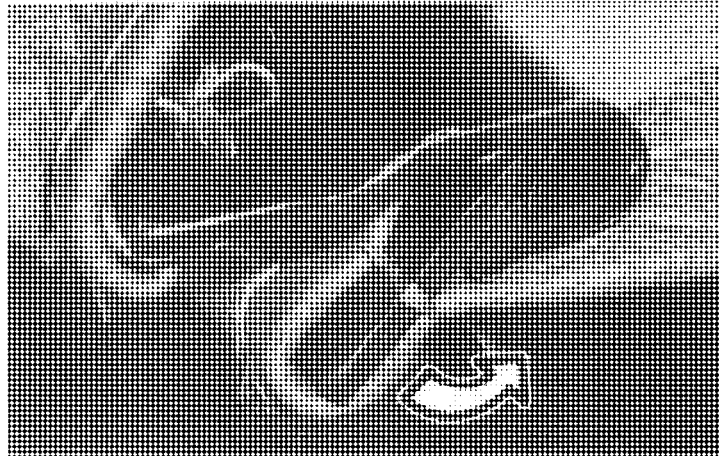

FIGURE 5. Two Piece Clip for Seat Back Cover (Rotates to Disengage)

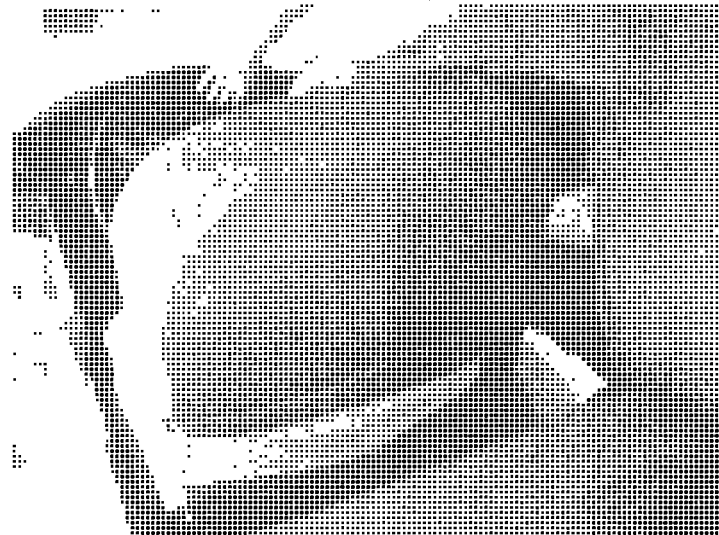

FIGURE 6.



FIGURE 7.

5. Starting at the upper back of the seat back, *carefully* pull the grey foam away from the left side of the seat back just enough to expose the top of the seat belt channel on the rear of the seat. The grey foam is attached with adhesive. See FIGURE 8.

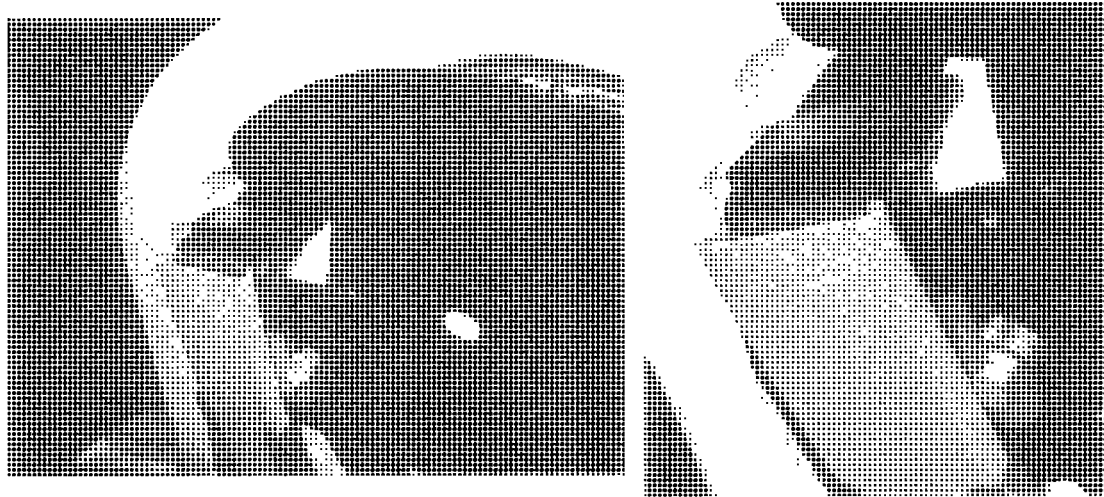

FIGURE 8. Seat Belt Channel and Guide (Grey Foam Removed for Clarity)

NOTE: In the following steps, the new seat belt guard is used as a template to mark and drill two holes. Do not mark the holes until the guard is correctly positioned. Mark the holes with a center punch before drilling, to prevent the drill bit from 'walking'.

6. Position the belt guard so that its top flange is over the top of the black plastic belt guide and the guard is not touching the seat belt. This should position the right side hole approximately  $\frac{1}{4}$  inch below the edge of the bracket being drilled. Mark the location with a center punch and drill an  $\frac{11}{64}$  inch diameter hole. Install the right side screw (provided in kit), but leave the screw loose enough to allow some movement of the guard. See FIGURES 9 and 10.



FIGURE 9.

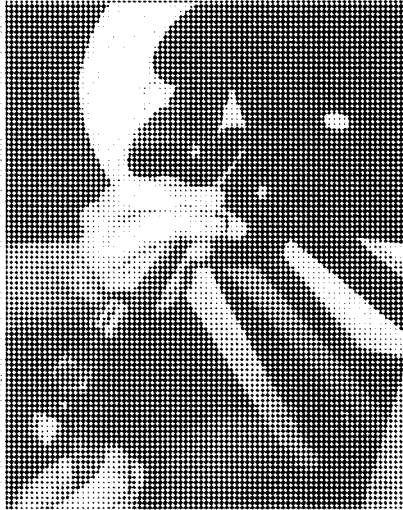

FIGURE 10.

7. Using the guard as a guide, drill an 11/64 inch diameter hole for the left side screw. Install the provided screw.
8. Tighten both screws. See FIGURE 11.

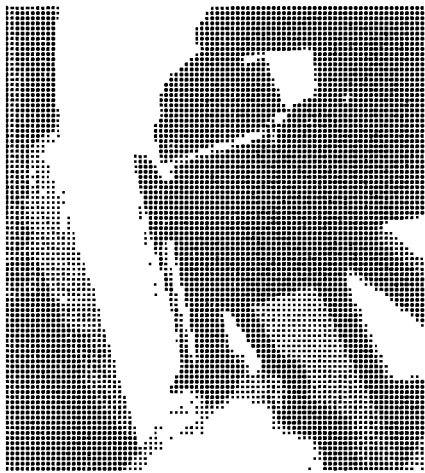

FIGURE 11.

NOTE: In the following step duct tape may be used, if necessary, to secure the grey foam and prevent it from shifting while installing the seat cover.

9. Return the grey foam to its original position, then slide the seat cover down the seat back.
10. Stretch the cover to reconnect the clips attached to the front and back cover flaps at the bottom of the seat back. Insert the front flap clip into the groove of the back flap clip until the clip barb is engaged. See FIGURE 5.
11. Replace arm.

12. Add sticker that indicates that recall has been performed on seat belt retractor. See FIGURE 12.

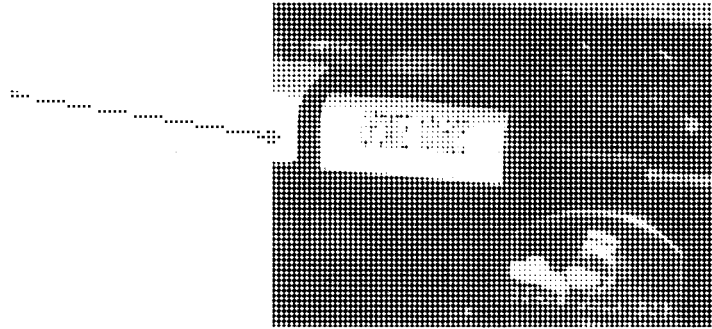
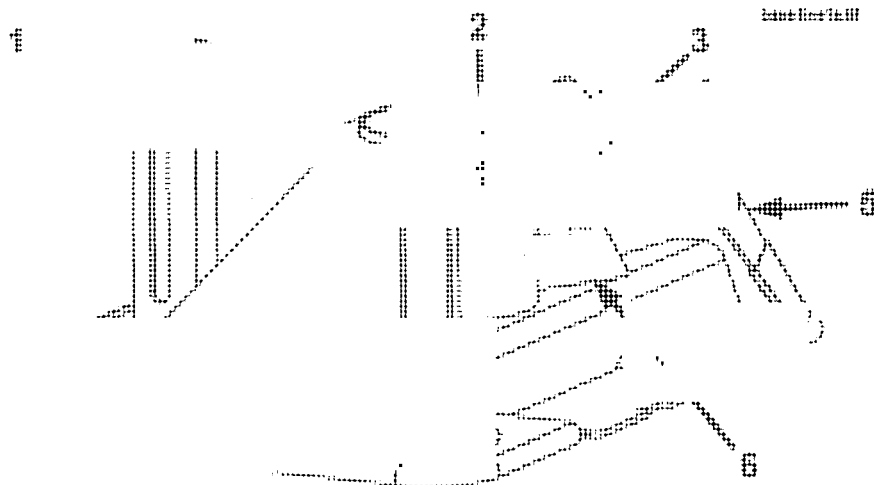

FIGURE 12.

End of Repair Procedure 1

### Repair Procedure 2 - Seat Height Lever Replacement -- Manual Seats

1. Disconnect any seat-to-floor tethers by unbolting them from the seat. **DO NOT** unbolt the tethers from the vehicle floor. Step 1 is also required to prepare for Repair Procedure 3.
2. If the seat is equipped with an up-stop mechanism, remove the limiting bolt and nut. See FIGURE 13. Retain this hardware for use during assembly. Step 2 is also required to prepare for Repair Procedure 3.
3. Loosen the seat height adjustment lock knob enough to allow seat height adjustment. Step 3 is also required to prepare for Repair Procedure 3.



1. UP-STOP MECHANISM BOLT AND NUT
2. ROLL PIN
3. SEAT HEIGHT ADJUSTMENT LOCK KNOB
4. SPRING CAGE
5. SEAT HEIGHT PIN / LEVER
6. TENSION SPRING

FIGURE 13.

4. With seat height lever raised to disengage, lift upper seat assembly off of lower base. Set the upper seat assembly aside. This step is also required for Repair Procedure 3.
5. Remove the roll pin from the shaft of the seat height lever using one of the following methods.
  - a. If the base has an access hole aligned with the roll pin (on the opposite side from the slot) remove the pin with a hammer and punch. See FIGURE 14.
  - b. If no access hole is present, attempt to grasp the roll pin using locking pliers and remove it by tapping the pliers with a hammer.
  - c. If neither of the previous two methods works, drill a 3/8 inch diameter access hole in the spring cage, aligned with the roll pin; then remove the pin with a hammer and punch. See FIGURE 14 for location of access hole. **IMPORTANT:** Before drilling, mark the hole location using a center punch to prevent the drill bit from 'walking'. After drilling hole, remove all metal shavings to prevent them from damaging the seat mechanism.
6. Discard the old roll pin. A new longer pin is supplied in the kit.

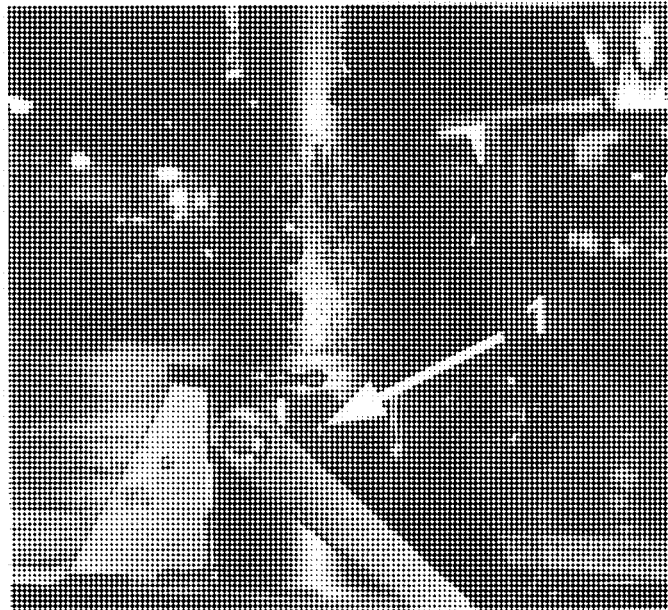

Figure 14. Roll Pin Access Hole

7. Remove the tension spring and the lever assembly from the seat base. See FIGURE 13. Retain the tension spring and discard the old lever assembly.
8. While holding the tension spring in place, insert the new seat height lever into position in the seat base, capturing the tension spring

**CAUTION:** In the following step the new roll pin **MUST BE** installed with the groove on top.

9. Using locking pliers, compress the tension spring; then, use a hammer to install the new roll pin. See FIGURES 15 & 16. The roll pin is correctly installed when the following conditions are met:
- The groove in the roll pin is facing up.
  - The pin must be driven far enough through the shaft so that the tension spring rests against the pin on both sides of the shaft.
  - The leading end of the pin must not contact the wall of the spring cage when the seat height lever is moved through its range.
  - The pin must protrude at least 7/16 inch outside of the slotted surface when the seat height lever is in the down (engaged) position.
10. Apply grease to the roll pin and slot prior to operating seat height lever.

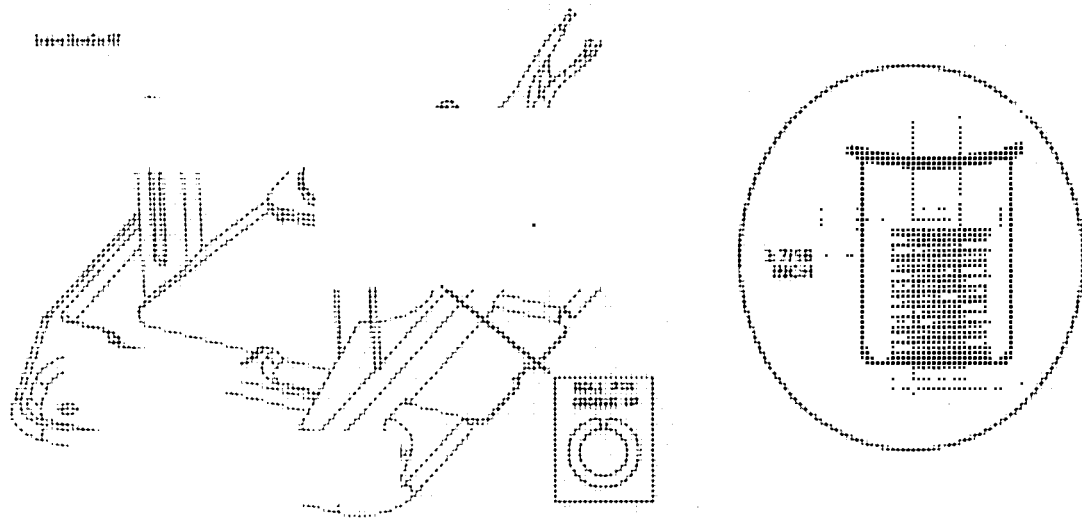

FIGURE 15.

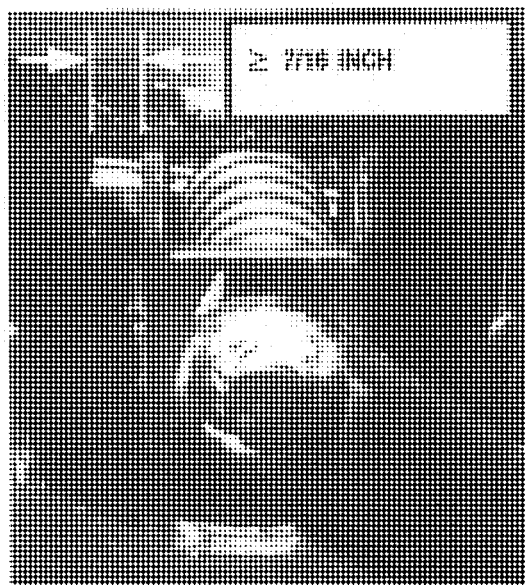

FIGURE 16.

**NOTE:** The following step is a two person operation. While one person lowers the seat assembly, the other person must guide the seat assembly to insure that the springs, cylinders, and up-stop mechanism are correctly aligned. See FIGURE 17.

11. Assemble the seat by lowering the seat assembly onto the lower seat base. Once the base components are correctly aligned, raise (disengage) the seat height lever and push down on the seat. When the seat reaches its top position, release the lever to engage the seat height locking pin. Step 11 is not required if proceeding to complete Repair Procedure 3.

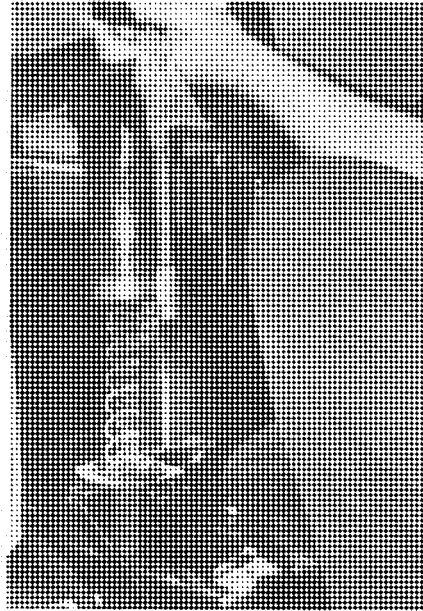

FIGURE 17.

12. Verify that the seat is in its top position (3 holes visible in seat base cylinder). See FIGURE 15. If the seat is equipped with an up-stop mechanism, install the limiting bolt and nut that were removed at the beginning of this procedure. Do not over tighten the nut, or the seat will not move up and down. The limiting bolt will prevent the seat from being raised beyond its top position. Step 12 is not required if proceeding to complete Repair Procedure 3.
13. Leaving the seat in its top position, connect the seat-to-floor tethers and adjust them to a tight condition. Step 13 is not required if proceeding to complete Repair Procedure 3.

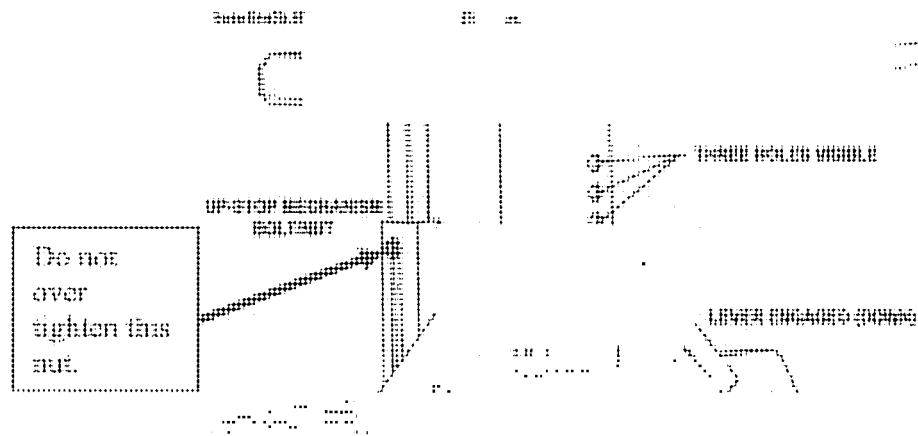

FIGURE 18.

End of Repair Procedure 2

### Repair Procedure 3 – Supplemental Seat Height Spring and Spring Retainer – Manual Seats

1. Disconnect any seat-to-floor tethers by unbolting them from the seat. **DO NOT** unbolt the tethers from the vehicle floor. If continuing from Repair Procedure 2, this step should already be complete.
2. If seat is equipped with an up-stop mechanism, remove the limiting bolt and nut. See FIGURE 19. Retain this hardware for use during assembly. If continuing from Repair Procedure 2, this step should already be complete.
3. Loosen the seat height adjustment lock knob enough to allow seat height adjustment. If continuing from Repair Procedure 2, this step should already be complete.

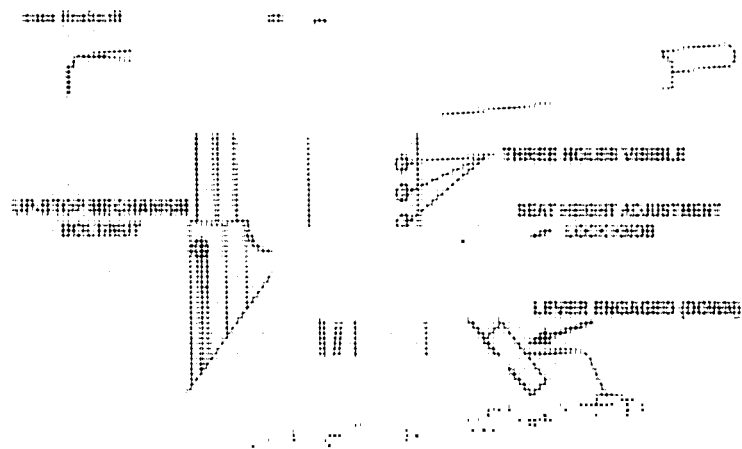

FIGURE 19.

4. With seat height lever raised to disengage, lift upper seat assembly off of lower base. If continuing from Repair Procedure 2, this step should already be complete.

- Partially remove the cover from the bottom seat cushion to allow access to the top of the seat base frame. Unclip cover from seat frame as needed. See FIGURE 20.

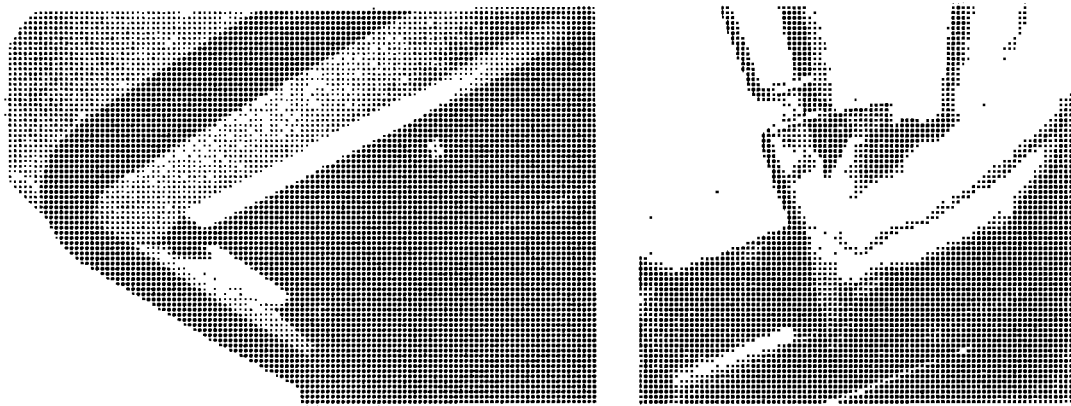

FIGURE 20.

- Install spring retainer plate on frame of seat bottom as indicated in FIGURE 21.
- Install supplemental seat height spring from kit inside of existing spring in seat base. See FIGURE 22.

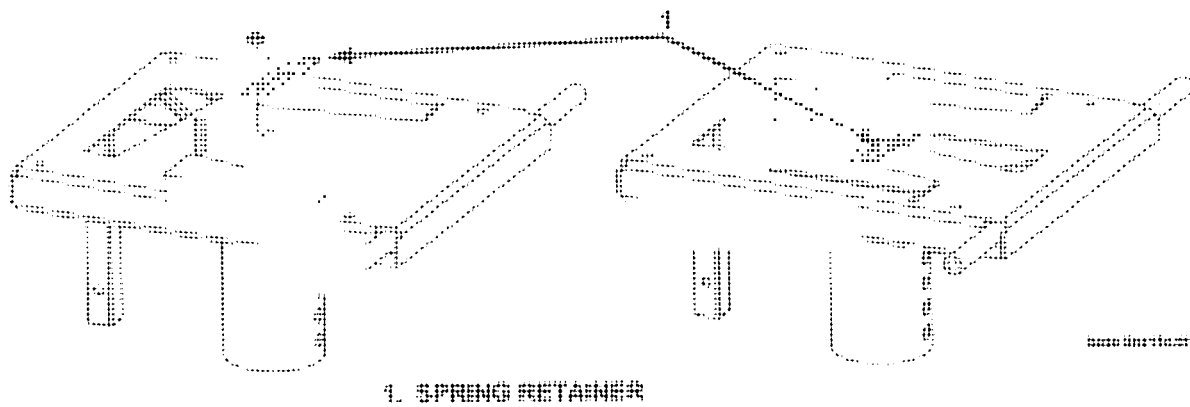

FIGURE 21.

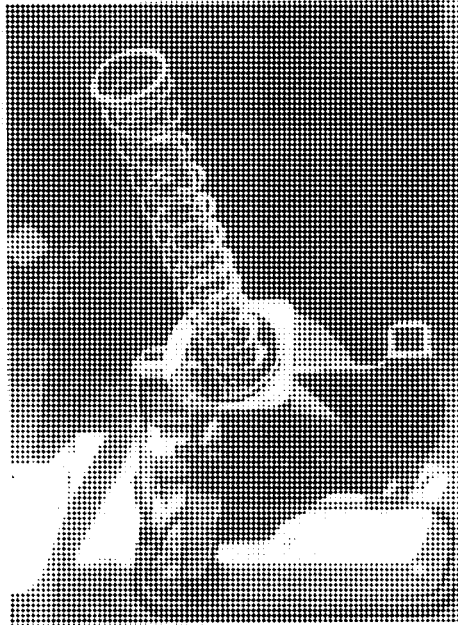

FIGURE 22.

**NOTE:** The following step is a two person operation. While one person lowers the seat assembly, the other person must guide the seat assembly to insure that the springs, cylinders, and up-stop mechanism are correctly aligned. See FIGURE 23.

2. Assemble the seat by lowering the seat assembly onto the lower seat base. Once the base components are correctly aligned, raise (disengage) the seat height lever and push down on the seat. When the seat reaches its top position, release the lever to engage the seat height locking pin. The lever will be in the down position.



FIGURE 23.

NOTE: The leathers that limit seat height travel have not yet been installed. If the seat is NOT equipped with an up-stop mechanism, do not allow the seat to rise above its top position, as it could become disengaged from the tower seat base.

- Verify that the seat is in its top position (3 holes visible in seat base cylinder). See FIGURE 24. If the seat is equipped with an up-stop mechanism, install the limiting bolt and nut that were removed at the beginning of this procedure. Do not over tighten the nut, or the seat will not move up and down. The limiting bolt will prevent the seat from being raised beyond its top position.

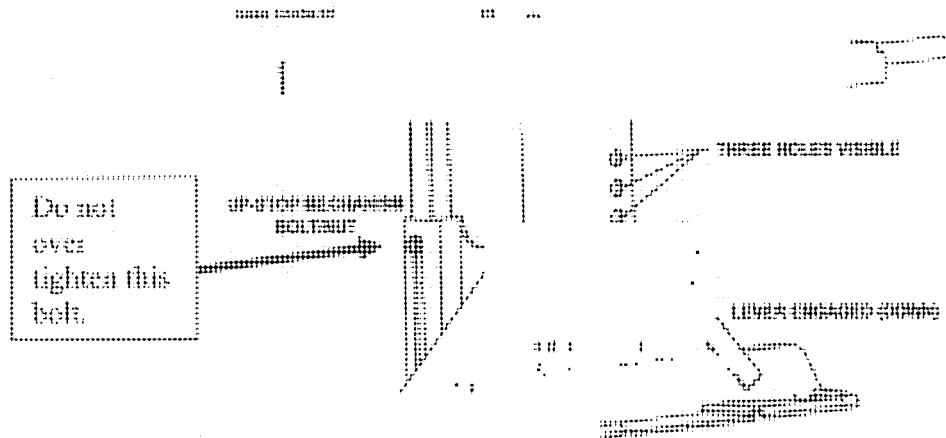

FIGURE 24.

- Through the opening at the top of the seat base cylinder, use a screwdriver to position the seat height springs away from the seat height locking pin. The springs should be adjusted so that they arc away from the locking pin (push over with screwdriver as shown on the left in FIGURE 25, push toward front of bus). This step creates the clearance needed to prevent interference between the seat height locking pin and the springs.

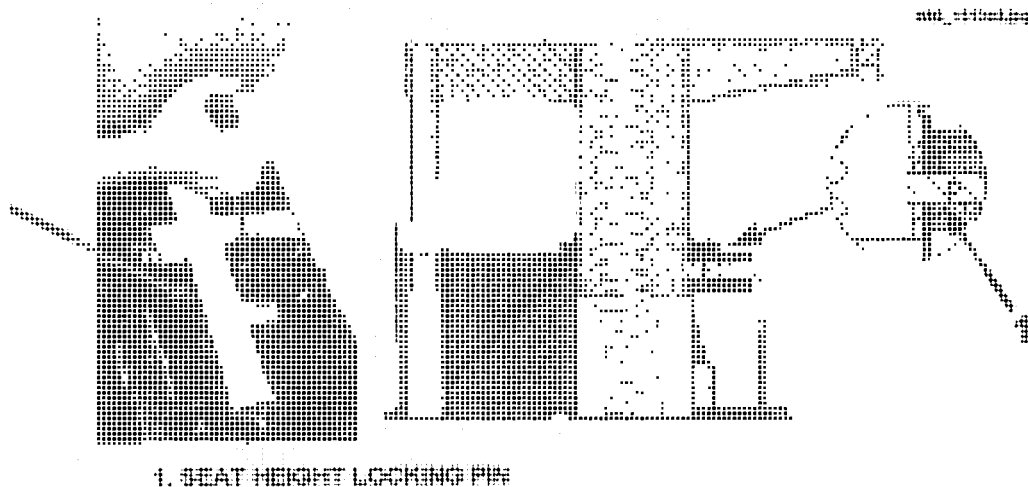

FIGURE 25.

11. Install cover on bottom seat cushion. See FIGURE 20.
  12. With the seat in its top position, adjust the seat-to-floor leathers to a tight condition. See FIGURE 24. If continuing to Repair Procedure 4, this step is not necessary.
- End of Repair Procedure 3

### Inspection for Seat Height Travel Limit (Prior To Repair Procedure 4)

Before Completing Repair 4, inspect the seat in order to determine if it has an up-stop mechanism. If your bus has this mechanism, Repair Procedure 4 will not have to be completed. See FIGURE 26.

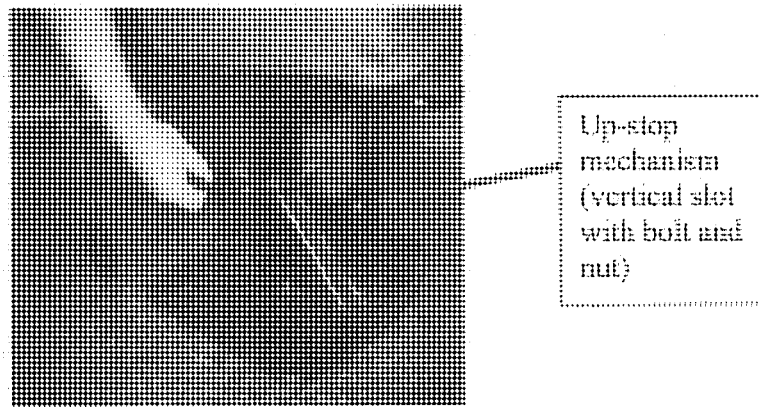

FIGURE 26.

End Inspection for Repair Procedure 4

### Repair Procedure 4 - National Bus Seat Service Letter -- Installation of New Seat Travel Tether

This kit is required on all manual seats that do not have a factory installed up-stop mechanism.

1. Loosen the seat height adjustment lock knob enough to allow seat height adjustment. See FIGURE 27. If continuing from Repair Procedure 2 and 3, this step should already be complete.
2. Raise the seat to its top position by lifting the seat height lever and lifting the seat. With the seat in its top position, three holes are visible on the rear of the seat base cylinder.
3. Ensure the locking pin is in position in the hole of the top adjustment hole.

**NOTE:** If seat-to-floor tethers prevent the seat from being raised to this position, loosen the tethers enough to allow the seat to reach its top position. Then retighten both the seat to floor tethers.

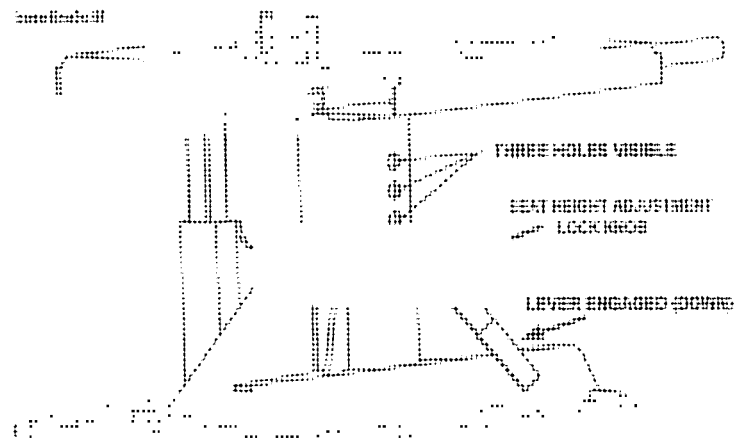

FIGURE 27.

NOTE: Use a center punch prior to drilling holes, to prevent drill bit from 'walking'.

4. Using a center punch, mark the location of the top hole on the front rail of the seat frame, as indicated in FIGURE 28.
5. Using a 3/8 inch bit, drill the top hole.

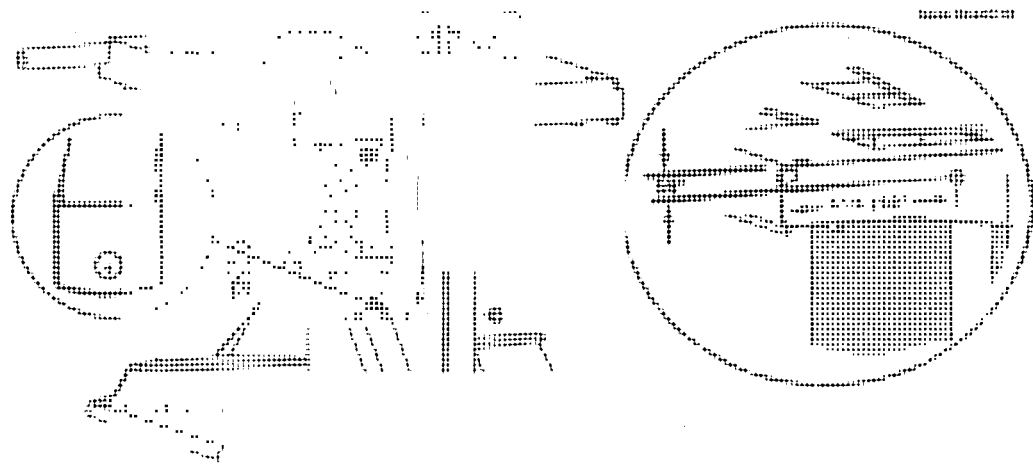

FIGURE 28.

6. Secure the top of the seat height travel tether using a bolt, washer, and nut provided in the kit.

NOTE: In the following step insure that the bottom hole is located so that it DOES NOT interfere with the seat base mechanism in any way. The bolt is a smaller diameter than the hole in the tether end plate, so the drilled hole must be offset slightly towards the end of the tether to insure that the tether is stretched tight when installed. See FIGURE 28.

7. Pull the tether tight and use the center punch to mark the location of the bottom hole. See FIGURE 28.
8. Using a 3/8 inch bit, drill the bottom hole.
9. Secure the bottom of the tether with the bolt, washer, and nut provided in the kit.
10. Leaving the seat in its top position, adjust the seat-to-floor tethers to a tight condition.

End of Repair Procedure 4

Please affix the Seat Adjustment Warning Label if there is not one attached to the seat already. This label may be ordered from the Compliance Department at Conway.

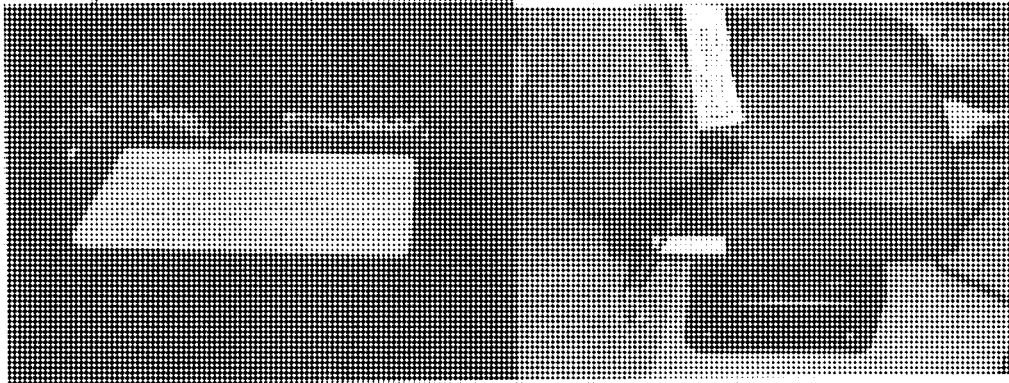

End of Repair Procedures

#### LABOR

Labor Code	Description	Time (hours)
A40-06512-01	install retractor cover on seatbelt (Repair 1)	0.4
A40-06512-02	install Lever Replacement (Repair 2)	0.3
A40-06512-03	install Supplemental Spring and Retainer (Repair 3)	0.2
A40-06512-04	inspect for Travel Stop (Inspection for Repair 4)	0.1
A40-06512-05	Install Seat Travel Tether (Repair 4)	0.1

#### CAMPAIGN IDENTIFICATION LABEL

*Each vehicle corrected in accordance with this campaign must be marked with a 300109 Campaign Identification Label.*

Complete the label and attach on a clean surface next to the vehicle identification number (VIN) plate.

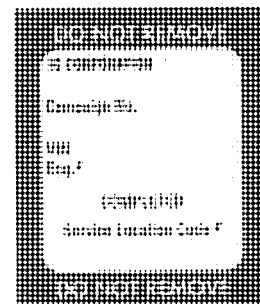

## **ADMINISTRATIVE/DEALER RESPONSIBILITIES (U.S. & POSSESSIONS)**

Proceed immediately to make necessary correction to units in inventory. **All inventory vehicles subject to this recall campaign must be corrected prior to sale, transfer or delivery.** If vehicles have been sold or transferred and you are in receipt of Customer Notification Letters and Authorization for Recall Service cards for those vehicles, the transfer location or customer must be notified **IMMEDIATELY** from your dealer location.

Dealers must correct all vehicles subject to this campaign at no charge to the owner, regardless of mileage, age of vehicle, or ownership, from this time forward. The National Traffic and Motor Vehicle Safety Act, as amended, provides that each vehicle that is subject to a vehicle recall campaign must be adequately **repaired** within a reasonable time after the owner has tendered it for repair. A failure to adequately repair within **60 days** after a tender of a vehicle is prima facie evidence of failure to repair within a reasonable time. If the condition is not adequately repaired within 60 days, the owner may be entitled to **replacement** with an identical or reasonable equivalent vehicle at no charge, or to a **refund** of the purchase price less a reasonable allowance for depreciation.

However, consistent with the customer notification, dealers are expected to complete the repairs on the mutually agreed upon service date. To avoid having to replace an owner vehicle or refund the purchase price, every effort must be made to promptly schedule an appointment with each owner to repair his or her vehicle as soon as possible.

During the recall process, a listing of owner names and addresses will be furnished to the involved dealers to enable dealers to follow up with owners and have the vehicles corrected. You must limit the use of this listing to this campaign because the list may contain information obtained from state motor vehicle registration records and the use of such motor vehicle registration data for purposes other than this campaign is a violation of law in several states.

## **POSSIBLE CUSTOMER REIMBURSEMENT**

There may be an occasion when a customer was charged for repairs related to this Recall prior to the Recall being released. The customer letter contains a statement for the customer to contact the Dealer if they believe they are entitled to reimbursement costs. The Dealer should follow the Customer Reimbursement guidelines in Warranty Policy Letter 03-001G. The Warranty Procedures and Administrative Policies manual (CTS1100) is in the process of being updated to include the information in Policy Letter 03-001G.

## **WARRANTY CLAIMS**

Refer to Dealer Warranty Manual for procedures to conduct Recall Campaigns.

It is important that the Recall Coding be completed properly to assist in processing the warranty claim. Complete instructions will be found in the Warranty Manual, Section 7-1. Special attention should be given to Items 39 through 44:

	GROUP	NOUN	C	WARR.	TP	PAD
GROUP Enter number G—						
NOUN Leave blank						
C (CAUSE) Enter either 1, 2, 3. (see below)						
1. Inspected (No repair required).						
2. Inspected and repaired.						
3. Defective part from parts stock.						
WARRANTY (Warranty Code) Enter 40.						
TYPE PART Enter P for type part causing failure.						
PAD Enter 100						

### **ADMINISTRATIVE/DISTRIBUTOR RESPONSIBILITY (EXPORT)**

Proceed immediately to make necessary correction to units in inventory. All inventory vehicles subject to this recall campaign must be corrected prior to sale, transfer or delivery. If vehicles have been sold or transferred and you are in receipt of Customer Notification Letters and Authorization for Recall Service cards for those vehicles, the transfer location or customer must be notified from your distributor location.

Export locations are to submit warranty claims in the usual manner making reference to this Recall number.

We ask for your full cooperation and follow-up to this important subject matter. If you have any questions or need further assistance, please contact the Regional Service Manager at your regional office.