

06V-283

RECEIVED

2006 SEP -1 A 10 47

VEHICLE RECALL

CLASSIFICATION SUBJECTS

G-06507
September, 2006

SUBJECT: NON-COMPLIANCE RECALL (U.S., EXPORT)
39" CE WHITE Track Mounted Child Safety Seats on certain BE & CE School Buses built between 08/03/2005 and 05/01/2006.

DEFECT DESCRIPTION

The configuration of the mounting bracket for the 39 inch track mounted CE White child safety seat does not provide sufficient strength to meet the requirements of FMVSS 210 if seat belts are attached. IC Corporation has not experienced any failures related to this issue.

MODELS INVOLVED

- PB405 (BESB) : 2007 Model Year
- PB105 (CESB) : 2006 and 2007 Model Years
- Feature Codes: 48TWX 48SLR 48SUT 48SCL 48SBM 48SYB 48SLL 48SLM 48SLP 48SRV 48SST 48SYC 48TBU 48TRS 48SRX 48BYP 48BYR

PARTS INFORMATION

Kit Part Number	Description	Contains
8900186R91	KIT, FIELD FIX CE WHITE 39 IN TRACK SEATS LH (left side)	2592744C1-1ea: Kit, Legs LH
		435054001-12 ea: Fitting, Track Seat Kinedyne
		452510001-12 ea: Fitting, Track Seat Q'Straint
		22264R1-16 ea: Washer, Flat
		2592743C1-1ea: Manual, Inst
8900187R91	KIT, FIELD FIX CE WHITE 39 IN TRACK SEATS RH (right side)	2592745C1-1ea: Kit, Legs RH
		435054001-12 ea: Fitting, Track Seat Kinedyne
		452510001-12 ea: Fitting, Track Seat Q'Straint
		22264R1-16 ea: Washer, Flat
		2592743C1-1ea: Manual, Inst



WARNING:

INVISIBLE ULTRAVIOLET AND INFRARED RAYS EMITTED IN WELDING CAN INJURE UNPROTECTED EYES AND SKIN. PROTECTION SUCH AS WELDER'S HELMET AND DARK COLORED FILTER LENSES OF THE PROPER DENSITY MUST BE USED. GTAW OR TIG WELDING WILL PRODUCE INTENSE RADIATION, THEREFORE, FILTER PLATE LENSES OF THE DEEPEST SHADE PROVIDING ADEQUATE VISIBILITY ARE RECOMMENDED. IT IS STRONGLY RECOMMENDED THAT PERSONS WORKING IN THE WELD AREA WEAR FLASH SAFETY GOGGLES. ALSO WEAR PROTECTIVE CLOTHING.



WARNING:

TO AVOID SERIOUS EYE INJURY, ALWAYS WEAR SAFE EYE PROTECTION WHEN YOU PERFORM VEHICLE MAINTENANCE OR SERVICE.



WARNING:

TO AVOID PROPERTY DAMAGE, PERSONAL INJURY, OR DEATH WHEN SERVICING THE VEHICLE, PARK ON A FLAT LEVEL SURFACE, SET THE PARKING BRAKE, SHUT THE ENGINE OFF AND CHOCK THE WHEELS.

INSPECTION PROCEDURE

Please inspect each bus to determine if this repair is necessary. The affected seats will have a mixture of leg types. See photos below. If there are two bolts behind both rear leg posts (toward the rear of the bus as shown in photo 2 below with 4 mounting bolts) the seat is okay. If there is only one bolt behind either leg post (toward the rear of the bus as shown in the photo 1 below with 3 mounting bolts), then the seat needs to be repaired.

Photo 1

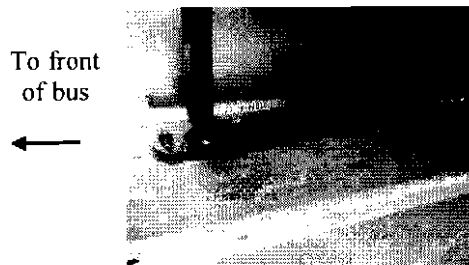

Original Outside leg –
3 mounting bolts

Photo 2



Original Aisle leg –
4 mounting bolts

REPAIR PROCEDURE

PLEASE read all instructions prior to starting the repair process.

Tags on the following figures refer to the following items:

ITEM	DESCRIPTION
1	Leg, BOL Track 10.75
2	Leg, BOL Track Offset
3	Brkt, front corner mount boomerang
4	Screw, 7/15-14X 1.25 Hex Head, Grade 5
5	Washer, 7/16 Flat, USS Zinc
6	Nut, 7/16-14 Nylock Zinc Plated
7	Nut, 1/4 -20 Nylock Zinc Plated
8	Screw, 1/4 -20 X 1.75 Hex Cap Gr 5 Zinc
9	Screw, 1/4 -20 X 1 Hex Head Gr 5
10	Washer, 1/4 Flat Zinc
11	Fitting, Track Kinedyne
12	Fitting, Track Q-Straint

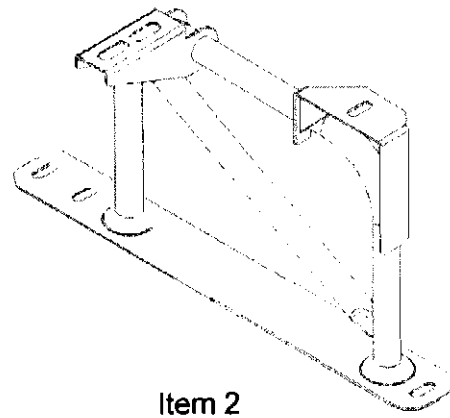
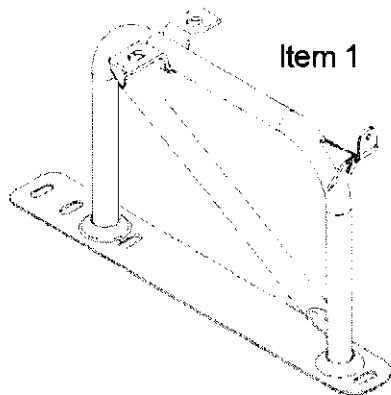

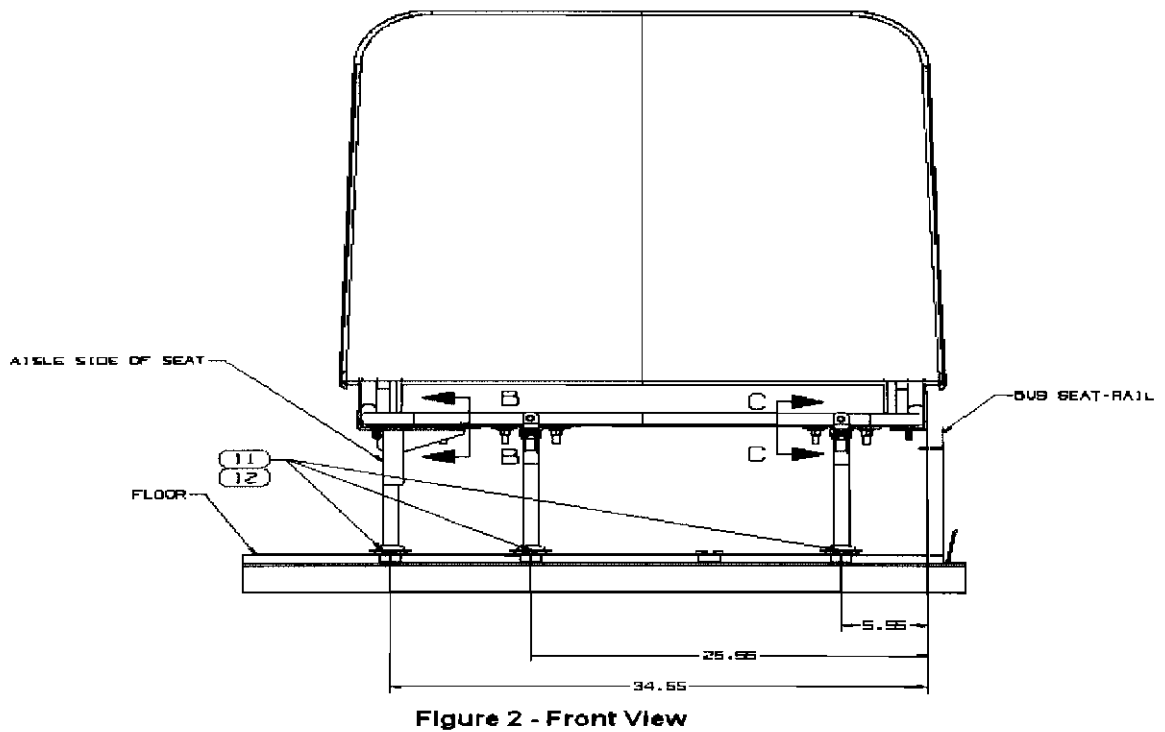
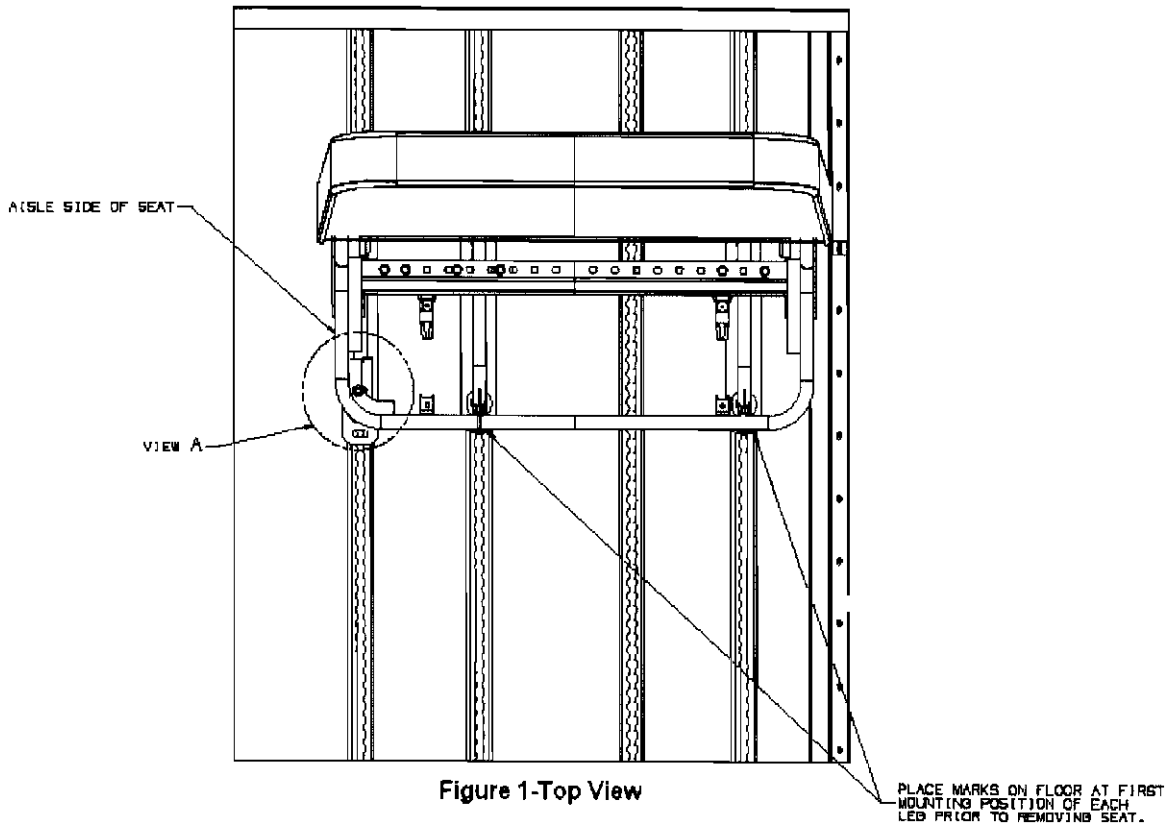

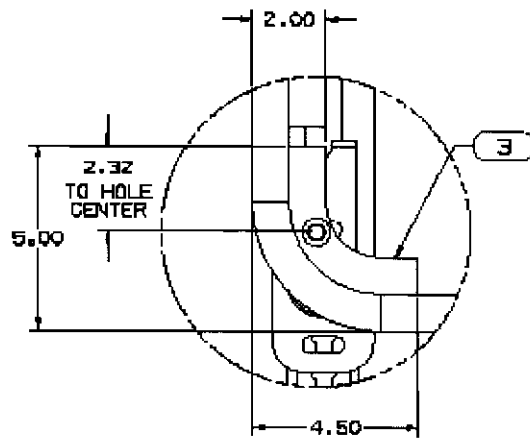

Figure 3-View A

SCALE 1:2

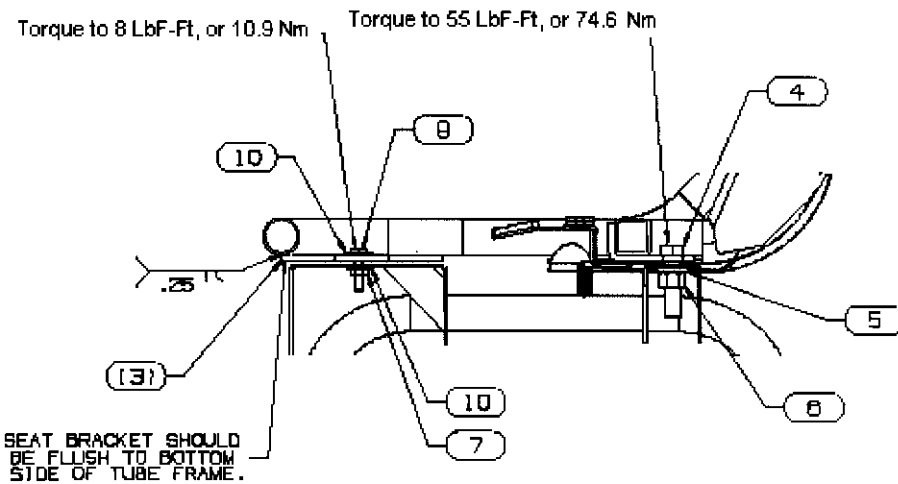

Figure 4-Section B-B

SCALE 1:2

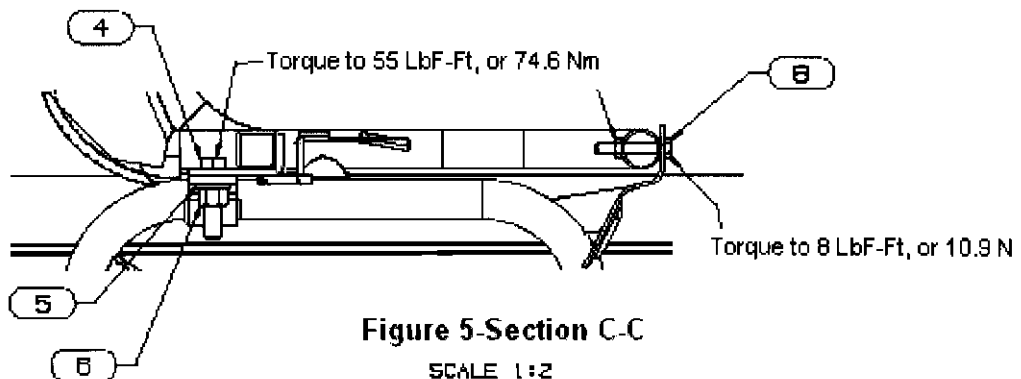
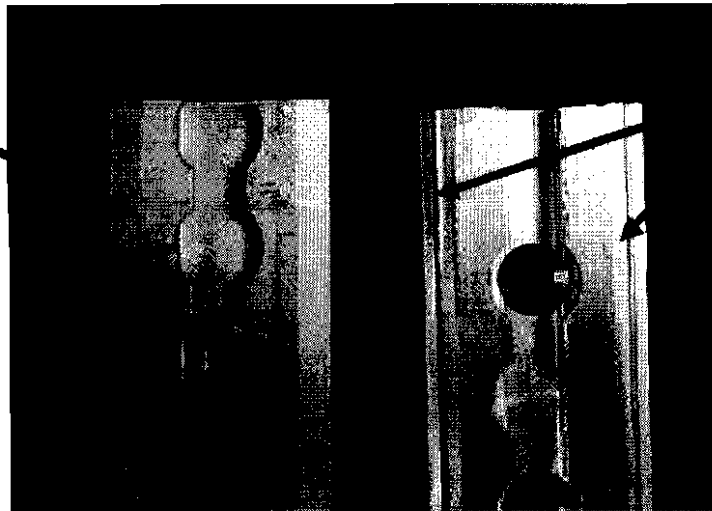

Figure 5-Section C-C

SCALE 1:2

1. Using a pencil (or any removable marking utensil or technique) mark the location of the seat. Place a mark on the floor next to the front track mounting position of each leg. See Figure 1, Top View.
2. Remove track hardware from seat legs and remove seat from vehicle.
3. Remove bottom seat cushion from frame by rotating the seat's two clips (located underneath the rear of the seat bottom) 90 degrees in either direction.
4. After rotating the seat clips, grasp the rear side of the seat and pull up.
5. Position the aisle side leg bracket. This is item 3 in Figure 3. Ensure that the bracket is flush with the bottom of the seat frame. Tack weld bracket into place.
6. Verify dimensional locations of the bracket. After verifying that the bracket is located correctly, complete the welding process as shown in section B-B. The weld should consist of a .25" bead along the outside edge of the bracket and seat frame. A weld blanket should be used to protect the seat back and seat belts.
7. Grind welds smooth to ensure the removal of any sharp edges created by adding the bracket.
8. Remove existing seat legs from the seat frame. These also may be removed prior to welding if desired.
9. Prime and paint welded area. Prime and paint surrounding areas as needed.
10. Install new legs provided with the kit. See Figure 1, Section B-B, and section C-C.
11. Reinstall the bottom seat cushion onto the seat frame.
12. Reinstall the seat in the location marked in step 1. Use item 11 with Kinedyne or Sure-Lok track (torque to 25-30 LbF-Ft, 34.9-47.6 Nm). Use item 12 with Q-Straint track (torque to 35 LbF-Ft, 47.4 Nm). Pictures below show the difference between the Kinedyne and Q'Straint type tracks.

Kinedyne or Sure Lock Track will have a smooth surface on the flanges of the track



Q'Straint track will have a rib on both flanges of the track

End of Repair Procedure

LABOR

Labor Code	Description	Time (hours)
A40-06507-01	Repair time per seat	1.4

CAMPAIGN IDENTIFICATION LABEL

*Each vehicle corrected in accordance with this campaign **must be marked** with a S00109 Campaign Identification Label.*

Complete the label and attach on a clean surface next to the vehicle identification number (VIN) plate.

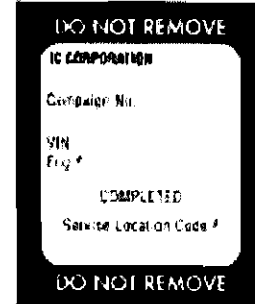

DO NOT REMOVE

IC CORPORATION

Campaign No. _____

VIN _____

Eq. # _____

COMPLETED

Service Location Code # _____

DO NOT REMOVE

ADMINISTRATIVE/DEALER RESPONSIBILITIES (U.S. & POSSESSIONS)

Proceed immediately to make necessary correction to units in inventory. **All inventory vehicles subject to this recall campaign must be corrected prior to sale, transfer or delivery.** If vehicles have been sold or transferred and you are in receipt of Customer Notification Letters and Authorization for Recall Service cards for those vehicles, the transfer location or customer must be notified **IMMEDIATELY** from your dealer location.

Dealers must correct all vehicles subject to this campaign at no charge to the owner, regardless of mileage, age of vehicle, or ownership, from this time forward. The National Traffic and Motor Vehicle Safety Act, as amended, provides that each vehicle that is subject to a vehicle recall campaign must be adequately **repaired** within a reasonable time after the owner has tendered it for repair. A failure to adequately repair within **60 days** after a tender of a vehicle is prima facie evidence of failure to repair within a reasonable time. If the condition is not adequately repaired within 60 days, the owner may be entitled to **replacement** with an identical or reasonable equivalent vehicle at no charge, or to a **refund** of the purchase price less a reasonable allowance for depreciation.

However, consistent with the customer notification, dealers are expected to complete the repairs on the mutually agreed upon service date. To avoid having to replace an owner vehicle or refund the purchase price, every effort must be made to promptly schedule an appointment with each owner to repair his or her vehicle as soon as possible.

During the recall process, a listing of owner names and addresses will be furnished to the involved dealers to enable dealers to follow up with owners and have the vehicles corrected. You must limit the use of this listing to this campaign because the list may contain information obtained from state motor vehicle registration

records and the use of such motor vehicle registration data for purposes other than this campaign is a violation of law in several states.

WARRANTY CLAIMS

Refer to Dealer Warranty Manual for procedures to conduct Recall Campaigns.

It is important that the Recall Coding be completed properly to assist in processing the warranty claim. Complete instructions will be found in the Warranty Manual, Section 7-1. Special attention should be given to Items 39 through 44:

	GROUP	NOUN	C	WARR.	TP	PAD
GROUP Enter number G—	_____	_____	_____	_____	_____	_____
NOUN Leave blank	_____	_____	_____	_____	_____	_____
C (CAUSE) Enter either 1, 2, 3. (see below)	_____	_____	_____	_____	_____	_____
1. Inspected (No repair required).	_____	_____	_____	_____	_____	_____
2. Inspected and repaired.	_____	_____	_____	_____	_____	_____
3. Defective part from parts stock.	_____	_____	_____	_____	_____	_____
WARRANTY (Warranty Code) Enter 40.	_____	_____	_____	_____	_____	_____
TYPE PART Enter P for type part causing failure.	_____	_____	_____	_____	_____	_____
PAD Enter 100	_____	_____	_____	_____	_____	_____

ADMINISTRATIVE/DISTRIBUTOR RESPONSIBILITY (EXPORT)

Proceed immediately to make necessary correction to units in inventory. All inventory vehicles subject to this recall campaign must be corrected prior to sale, transfer or delivery. If vehicles have been sold or transferred and you are in receipt of Customer Notification Letters and Authorization for Recall Service cards for those vehicles, the transfer location or customer must be notified from your distributor location.

Export locations are to submit warranty claims in the usual manner making reference to this Recall number.

We ask for your full cooperation and follow-up to this important subject matter. If you have any questions or need further assistance, please contact the Regional Service Manager at your regional office.